

84 Loader Repair

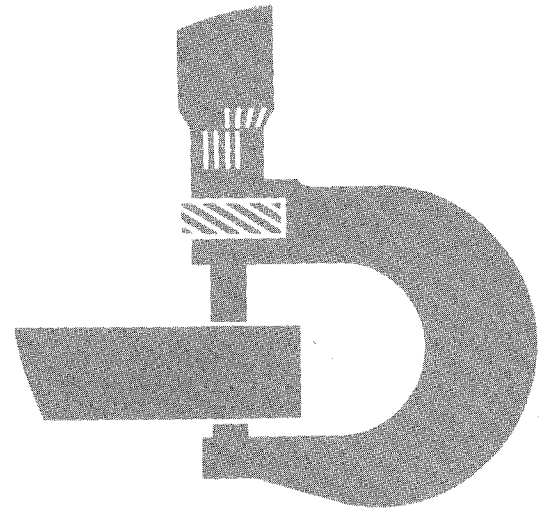

TECHNICAL MANUAL

TM1398 (08MAY90)

LITHO IN U.S.A.

FOREWORD

This manual is written for an experienced technician. Essential tools required in performing certain service work are identified in this manual and are recommended for use.

Live with safety: Read the safety messages in the introduction of this manual and the cautions presented throughout the text of the manual.



This is the safety-alert symbol. When you see this symbol on the machine or in this manual, be alert to the potential for personal injury.

Technical manuals are divided in two parts: repair and diagnostics. Repair sections tell how to repair the components. Diagnostic sections help you identify the majority of routine failures quickly.

Information is organized in groups for the various components requiring service instruction. At the beginning of each group are summary listings of all applicable essential tools, service equipment and tools, other materials needed to do the job, service parts kits, specifications, wear tolerances, and torque values.

Binders, binder labels, and tab sets can be ordered by John Deere dealers direct from the John Deere Distribution Service Center.

This manual is part of a total product support program.

FOS MANUALS—REFERENCE

TECHNICAL MANUALS—MACHINE SERVICE

COMPONENT MANUALS—COMPONENT SERVICE

Fundamentals of Service (FOS) Manuals cover basic theory of operation, fundamentals of troubleshooting, general maintenance, and basic type of failures and their causes. FOS Manuals are for training new personnel and for reference by experienced technicians.

Technical Manuals are concise guides for specific machines. Technical manuals are on-the-job guides containing only the vital information needed for diagnosis, analysis, testing, and repair.

Component Technical Manuals are concise service guides for specific components. Component technical manuals are written as stand-alone manuals covering multiple machine applications.

**IMPORTANT: Please remove this page and route
through your service department.**

This is a complete revision for TM1398, 84 Loader.

To make miscellaneous additions and corrections.

To update material per earlier and later units throughout
manual.

<https://www.ebooklibonline.com>

Hello dear friend!

Thank you very much for reading.

Enter the link into your browser.

The full manual is available for immediate download.

<https://www.ebooklibonline.com>

Contents

SECTION I—GENERAL INFORMATION

- Group I—Safety
- Group II—General Specifications
- Group III—Torque Values
- Group IV— Fuels and Lubricants
- Group V—Inspection Procedures

SECTION 01—WHEELS

- Group 0110—Powdered Wheels and Fastenings

SECTION 02—AXLES AND SUSPENSION SYSTEMS

- Group 0200—Removal and Installation
- Group 0210—Differential or Bevel Drive
- Group 0225—Input Drive Shafts and U-Joints
- Group 0250—Axle Shaft, Bearings, and Reduction Gears

SECTION 03—TRANSMISSION

- Group 0300—Removal and Installation
- Group 0315—Controls Linkage
- Group 0350—Gear, Shafts, Bearings, and Power Shift Clutch
- Group 0360—Hydraulic System

SECTION 04—ENGINE

- Group 0400—Removal and Installation

SECTION 05—ENGINE AUXILIARY SYSTEMS

- Group 0505—Cold Weather Starting Aids
- Group 0510—Cooling System
- Group 0515—Speed Controls and Manual Fuel Shut-off Linkage
- Group 0520—Intake System
- Group 0560—External Fuel Supply Systems

SECTION 09—STEERING SYSTEM

- Group 0960—Hydraulic System

SECTION 10—SERVICE BRAKES

- Group 1011—Active Elements
- Group 1015—Controls Linkage
- Group 1060—Hydraulic System

SECTION 11—PARK BRAKE

- Group 1111—Active Elements
- Group 1115—Controls Linkage

SECTION 16—ELECTRICAL SYSTEMS

- Group 1672—Alternator, Regulator, and Charging System Wiring
- Group 1673—Lighting System
- Group 1674—Wiring Harness and Switches
- Group 1675—Systems Control

SECTION 17—FRAME, CHASSIS

- Group 1740—Frame Installation
- Group 1749—Chassis Weights

SECTION 18—OPERATOR'S STATION

- Group 1800—Removal and Installation
- Group 1810—Operator Enclosure
- Group 1821—Seat and Seat Belt
- Group 1830—Heating and Air Conditioning

SECTION 19—SHEET METAL AND STYLING

- Group 1910—Hood or Engine

SECTION 31—LOADER

- Group 3102—Bucket
- Group 3115—Controls Linkage
- Group 3140—Frames
- Group 3160—Hydraulic System

SECTION 99—DEALER FABRICATED TOOLS

- Group 9900—Dealer Fabricated Tools

Alphabetical Index

All information, illustrations and specifications in this manual are based on the latest information available at the time of publication. The right is reserved to make changes at any time without notice.

TM1398-19-08MAY90

COPYRIGHT® 1990
DEERE & COMPANY
Moline, Illinois
All rights reserved
A John Deere ILLUSTRATION™ Manual
Previous Editions
Copyright® 1987 Deere & Company

Section I GENERAL INFORMATION

Contents

Page

Group I—Safety

Park Machine Safely	I-I-3
Service Machine Safely	I-I-4
Use Seat Belt	I-I-6
Live with Safety	I-I-9

Group II—General Specifications

Machine	I-II-1
Engine	I-II-2
Fluid Capacities	I-II-4

Group III—Torque Values

Group IV— Fuels and Lubricants

Engine Oil	I-IV-2
Transmission Oil	I-IV-3
Differential Oil	I-IV-4
Hydraulic Oil	I-IV-5
Grease	I-IV-6

Group V—Inspection Procedures

PIP I	I-V-6
PIP II	I-V-8

HANDLE FLUIDS SAFELY—AVOID FIRES

When you work around fuel, do not smoke or work near heaters or other fire hazards.

Store flammable fluids away from fire hazards. Do not incinerate or puncture pressurized containers.

Make sure machine is clean of trash, grease, and debris.

Do not store oily rags; they can ignite and burn spontaneously.



O53,FLAME -19-26JAN90

TS227 -UN-23AUG88

PREVENT BATTERY EXPLOSIONS

Keep sparks, lighted matches, and open flame away from the top of battery. Battery gas can explode.

Never check battery charge by placing a metal object across the posts. Use a volt-meter or hydrometer.

Do not charge a frozen battery; it may explode. Warm battery to 16°C (60°F).

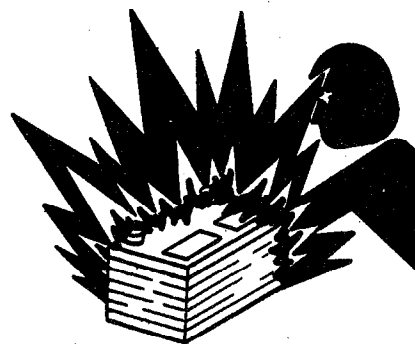

O53,SPARKS -19-26JAN90

TS204 -UN-23AUG88

PREPARE FOR EMERGENCIES

Be prepared if a fire starts.

Keep a first aid kit and fire extinguisher handy.

Keep emergency numbers for doctors, ambulance service, hospital, and fire department near your telephone.

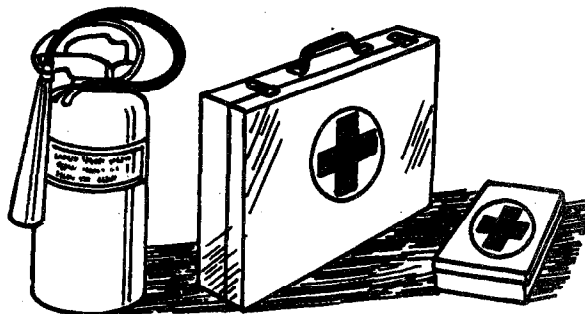

O53,FIRE2 -19-26JAN90

TS291 -UN-23AUG88

PREVENT ACID BURNS

Sulfuric acid in battery electrolyte is poisonous. It is strong enough to burn skin, eat holes in clothing, and cause blindness if splashed into eyes.

Avoid the hazard by:

1. Filling batteries in a well-ventilated area.
2. Wearing eye protection and rubber gloves.
3. Avoiding breathing fumes when electrolyte is added.
4. Avoiding spilling or dripping electrolyte.
5. Use proper jump start procedure.

If you spill acid on yourself:

1. Flush your skin with water.
2. Apply baking soda or lime to help neutralize the acid.
3. Flush your eyes with water for 10—15 minutes. Get medical attention immediately.

If acid is swallowed:

1. Drink large amounts of water or milk.
2. Then drink milk of magnesia, beaten eggs, or vegetable oil.
3. Get medical attention immediately.

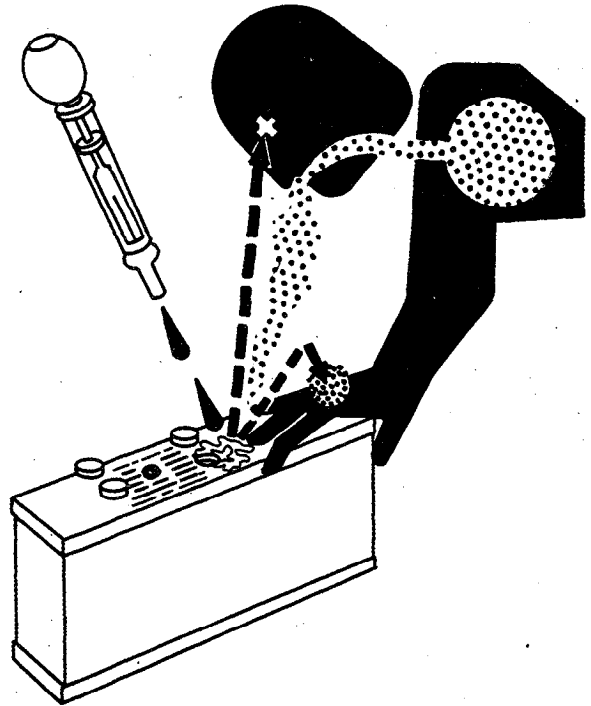

O53,POISON -19-26JAN90

TS203 -JUN-23AUG88

AVOID HIGH-PRESSURE FLUIDS

Escaping fluid under pressure can penetrate the skin causing serious injury.

Avoid the hazard by relieving pressure before disconnecting hydraulic or other lines. Tighten all connections before applying pressure.

Search for leaks with a piece of cardboard. Protect hands and body from high pressure fluids.

If an accident occurs, see a doctor immediately. Any fluid injected into the skin must be surgically removed within a few hours or gangrene may result. Doctors unfamiliar with this type of injury may call the Deere & Company Medical Department in Moline, Illinois, or other knowledgeable medical source.

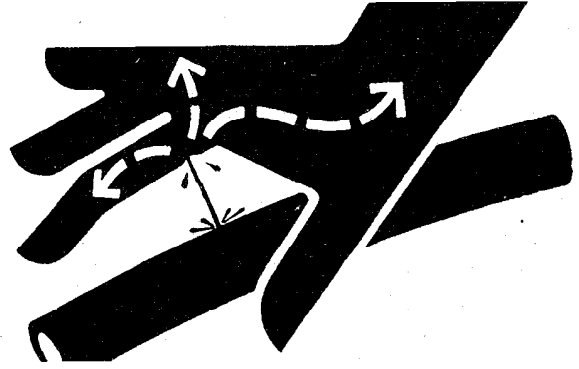

X9811 -UN-29AUG88

O53,FLUID -19-26JAN90

PARK MACHINE SAFELY

Before working on the machine:

- Lower all equipment to the ground.
- Stop the engine and remove the key.
- Disconnect the battery ground strap.
- Hang a "DO NOT OPERATE" tag in operator station.

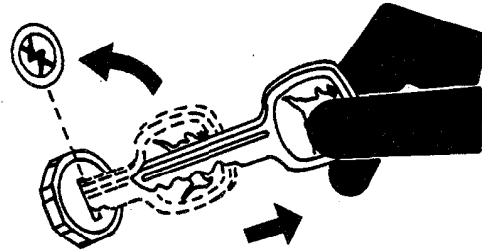

TS230 -UN-24MAY89

O53,PARK -19-26JAN90

SERVICE EQUIPMENT AND TOOLS

*NOTE: Order tools from your SERVICE-GARD™ Catalog.
Some tools may be available from a local
supplier.*

Name	Use
Internal Puller	To remove input pinion bearing cups.
Puller Set	To remove bearing cones.
74, 78, 81	To install bearing cups and input pinion oil
(2-29/32, 3-5/64, 3-3/16 in.) Disks	seal.
Spring Scale	
(0—5 kg, 0—10 lb range)	To measure differential preload.
Dial Indicator (0—25 mm, 0—1.0 in. range)	To measure backlash.

0210,40 -19-20APR90

OTHER MATERIAL

Number	Name	Use
	Paint or dye	To check tooth contact patterns.
TY6304	Flexible Sealant	On front differential plate mounting surface.
TY43512	Thread Lock and Sealer	On O.D. of input pinion oil seal.
	(Medium Strength)	On brake piston housing cap screws. On differential carrier cap screws. On differential adjusting nuts lock plates cap screws. On input pinion cap screws.
AT38226	Epoxy	On ring gear cap screws.

0210,41 -19-03MAY90

SPECIFICATIONS

Item	Measurement	Specification
Input Pinion Shaft To-Flange Cap Screw	Torque	108 N·m (80 lb-ft)
Ring Gear Cap Screws	Torque	108 N·m (80 lb-ft)
Input Pinion Cap Screws	Torque	59 N·m (44 lb-ft)
Brake Piston Housing Cap Screws	Torque	30 N·m (22 lb-ft)
Differential Carrier Cap Screws	Torque	59 N·m (44 lb-ft)
Adjusting Nuts Lock Plates Cap Screws	Torque	30 N·m (22 lb-ft)
Front Differential Plate Cap Screws	Torque	59 N·m (44 lb-ft)
Rear Axle Pin Cap Screws	Torque	59 N·m (44 lb-ft)
Differential Housing	Preload	2.2—2.75 kg (4.8—6.1 lb)
Differential Ring Gear	Backlash	0.15—0.20 mm (0.006—0.008 in.)

0210,42 -19-20APR90

REMOVE DIFFERENTIAL AND INPUT PINION

1. Remove axles. (See Disassemble Axle, Group 0250.)

NOTE: Identify right and left axle and differential parts to aid at installation.

2. Remove piston (A). Remove O-rings (B) from piston.

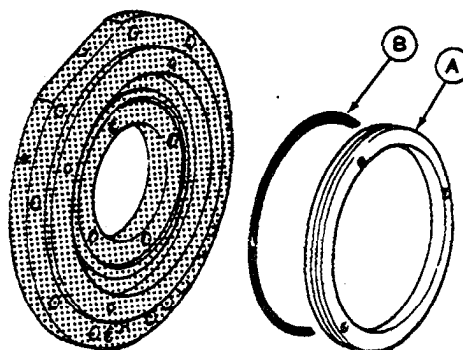

0210,01 -19-20APR90

T6499LH -JUN-19MAY89

Differential or Bevel Drive/Differential and Input Pinion

3. Remove lock plate (A) and adjusting nut (B).

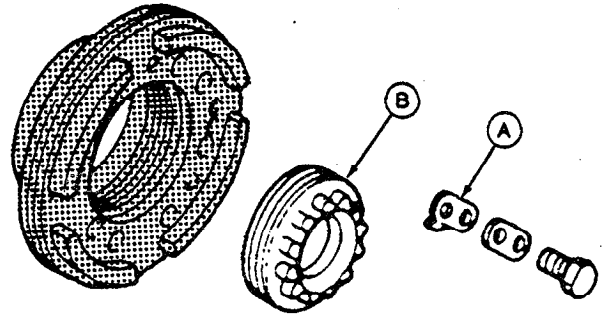

0210,02 -19-20APR90

T6439LI -UN-19MAY89

4. Remove carrier.

5. Remove bearing cup (A).

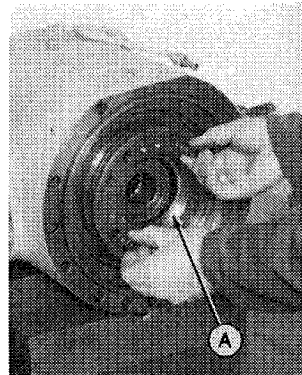

0210,03 -19-20APR90

T6439LK -UN-18OCT88

6. Remove brake piston housing.

7. Remove brake line (A).

8. Remove input pinion (B) and shims (C).

9. Remove parts from the other side.

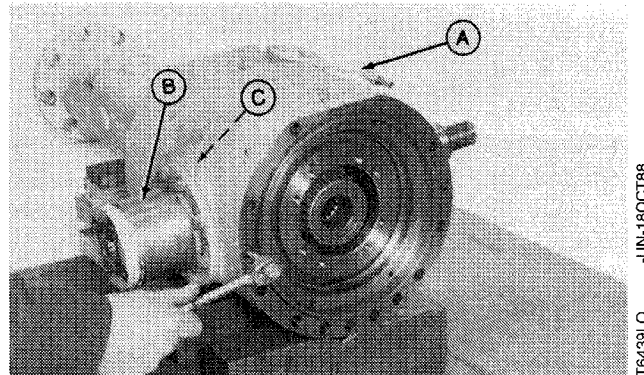

0210,04 -19-20APR90

T6439LO -UN-18OCT88

10. Remove differential.

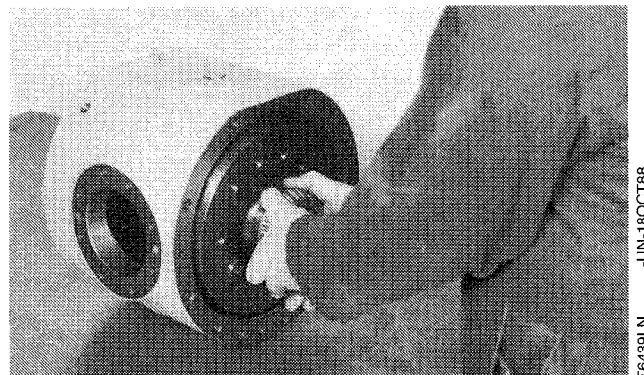

0210,06 -19-20APR90

T6439LN -UN-18OCT88

11. Remove plate from front differential.
12. Remove pin from rear differential using pusher screws.
13. Remove O-ring from pin.

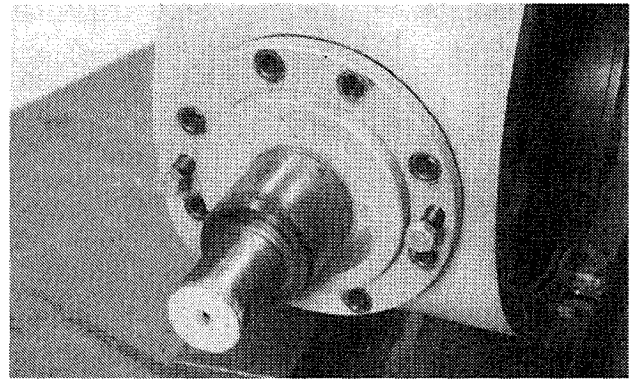
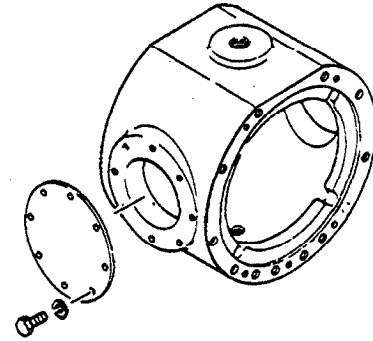

0210,09 -19-20APR90

T6439LV -JUN-19MAY89
T6439LU -JUN-18OCT88

DISASSEMBLE DIFFERENTIAL

1. Remove cap screws (1) and lock washers (2).
 2. Remove bevel gear (3).
 3. Inspect bearings (4 and 5). Remove with a puller if necessary.
- NOTE: If bearings (4 and 5) are replaced, bearing cups must be replaced.*
4. Inspect bearing cups (6 and 7). Replace if necessary.
 5. Remove thrust washer (8) and bevel gear (9).
 6. Remove pin (10).
 7. Remove pinion shaft (11), side gears (12 and 13), and thrust washers (14 and 15).
 8. Remove bevel gear (16) and thrust washer (17).
 9. Remove spring pins (18 and 19) only if they are damaged.

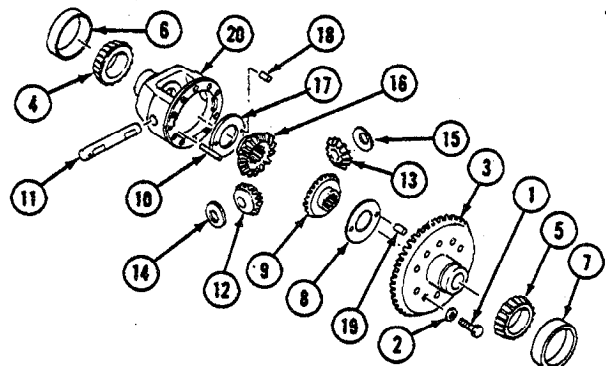

- | | |
|-----------------|-------------------------|
| 1—Cap Screw | 11—Pinion Shaft |
| 2—Lock Washer | 12—Side Gear |
| 3—Ring Gear | 13—Side Gear |
| 4—Bearing Cone | 14—Thrust Washer |
| 5—Bearing Cone | 15—Thrust Washer |
| 6—Bearing Cup | 16—Bevel Gear |
| 7—Bearing Cup | 17—Thrust Washer |
| 8—Thrust Washer | 18—Spring Pin |
| 9—Bevel Gear | 19—Spring Pin |
| 10—Pin | 20—Differential Housing |

0210,11 -19-20APR90

T6439LX -JUN-19MAY89

ASSEMBLE DIFFERENTIAL

1. Install spring pins (18 and 19) until 2 mm (0.08 in.) protrudes above surface.

CAUTION: Heat parts in a bearing heater. Use a thermometer and do not exceed 150°C (300°F). Plan a safe handling procedure to avoid burns.

2. Install bearings (4 and 5). Heat bearing cone not to exceed 150°C (300°F). Install heated bearing cone tight against shoulder.

3. Coat both sides of thrust washer (17) with hydraulic oil. Install thrust washer and bevel gear (16).

4. Coat both sides of thrust washers (14 and 15) with hydraulic oil. Coat pinion shaft (11) with oil soluble grease.

5. Lock pin hole in pinion shaft (11) must be positioned to align with hole in differential housing (20). Install pinion shaft, thrust washer (14), side gears (12 and 13), and thrust washer.

6. Press pinion shaft (11) into differential housing (20) until lock pin hole is aligned with hole in housing. Install pin (10). The pin must not protrude from housing surface.

7. Coat both sides of thrust washer (8) with hydraulic oil. Install bevel gear (9) and thrust washer.

8. Install ring gear (3).

9. Apply epoxy adhesive or equivalent to lower threads of cap screws (1). Install cap screws and lock washers (2). Tighten cap screws in a crisscross pattern to 108 N·m (80 lb-ft). Repeat tightening pattern several times.

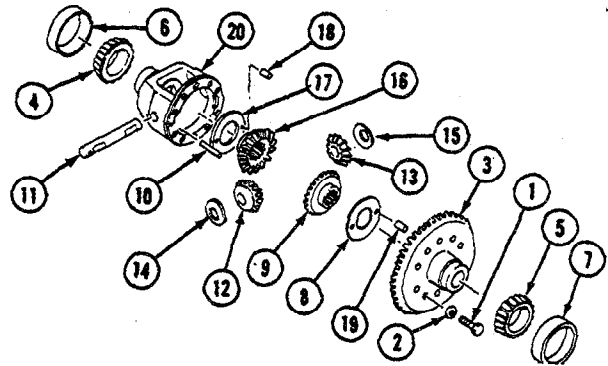

1—Cap Screw	11—Pinion Shaft
2—Lock Washer	12—Side Gear
3—Ring Gear	13—Side Gear
4—Bearing Cone	14—Thrust Washer
5—Bearing Cone	15—Thrust Washer
6—Bearing Cup	16—Bevel Gear
7—Bearing Cup	17—Thrust Washer
8—Thrust Washer	18—Spring Pin
9—Bevel Gear	19—Spring Pin
10—Pin	20—Differential Housing

TE439LX -JUN-19MAY89

DISASSEMBLE INPUT PINION

1. Remove pin (A) and cotter pin (B).
2. Remove cap screw (C) and spacer (D).
3. Identify shims (E) to aid at assembly. Remove shims.
4. Remove O-rings (F and G).

- | | |
|--------------|-------------|
| A—Spring Pin | E—Shim Pack |
| B—Cotter Pin | F—O-Ring |
| C—Cap Screw | G—O-Ring |
| D—Spacer | |

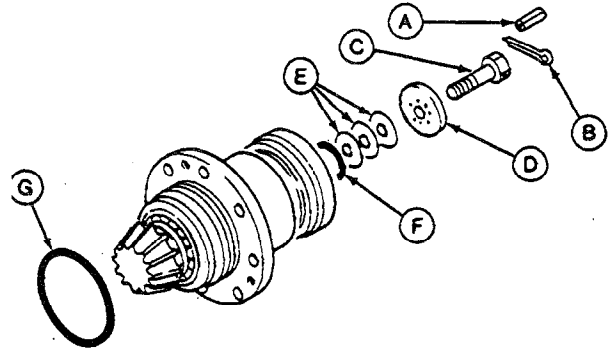

0210,13 -19-20APR90

T6439LL -UN-19MAY89

5. Remove input flange.

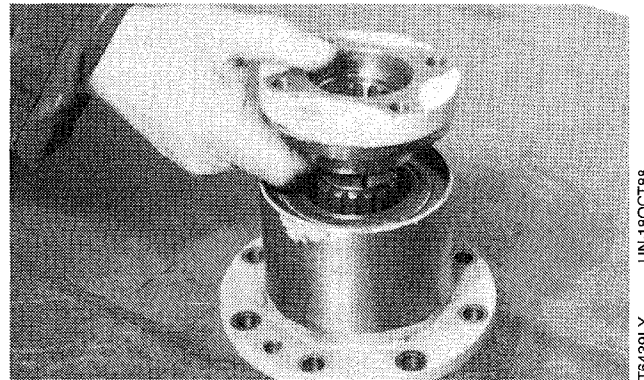

0210,14 -19-20APR90

T6439LY -UN-18OCT88

6. Remove pinion shaft.
7. Remove oil seal (A).

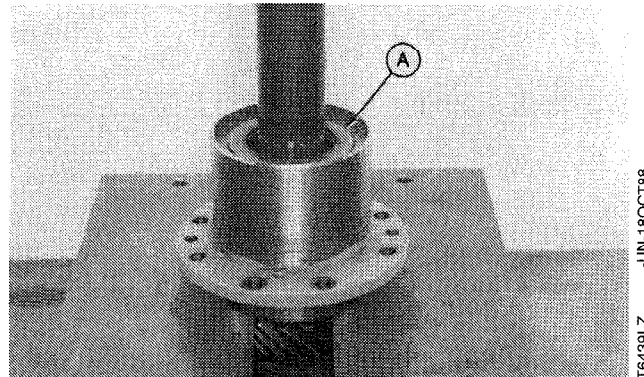

0210,15 -19-20APR90

T6439LZ -UN-18OCT88

Differential or Bevel Drive/Input Pinion

8. Remove bearing (A). Replace bearing cup (B) if bearing is replaced.

9. Inspect bearing cups (B and C). Remove with puller if replacement is necessary.

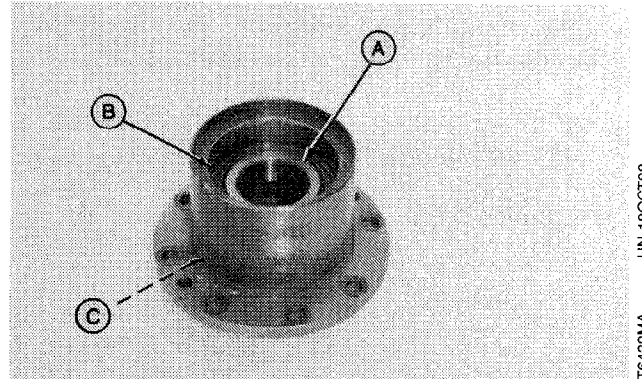

0210,16 -19-20APR90

T6439MA -JUN-18OCT88

10. Inspect bearing. Remove with puller if replacement is necessary.

NOTE: Replace bearing cup (C) in step 9 if bearing is replaced.

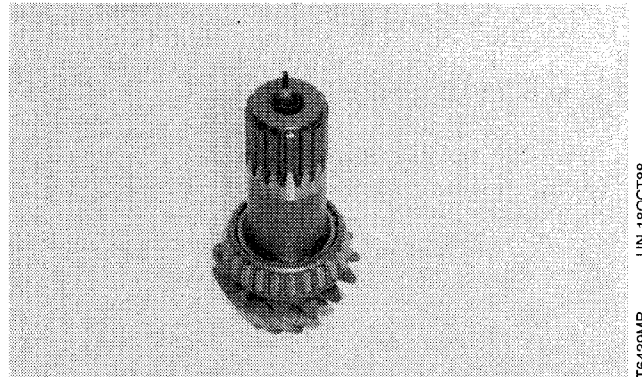

0210,17 -19-20APR90

T6439MB -JUN-18OCT88

ASSEMBLE INPUT PINION

CAUTION: DO NOT heat oil over 182C (360F). Oil fumes or oil can ignite above 193C (360F). Use a thermometer. Do not allow a flame or heating element to come in direct contact with the oil. Heat the oil in a well ventilated area. Plan a safe handling procedure to avoid burns.

1. Heat bearing cone to 150C (300F) and install on shaft.

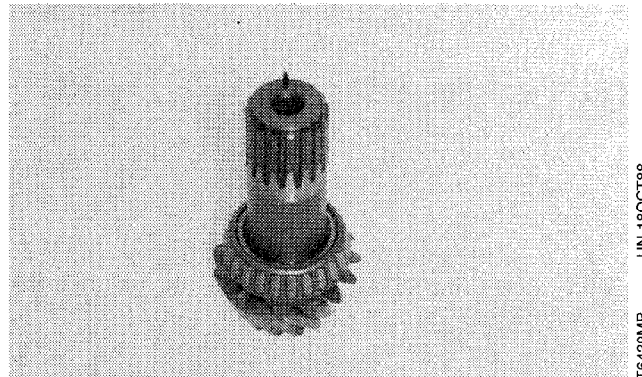

0210,18 -19-20APR90

T6439MB -JUN-18OCT88

Differential or Bevel Drive/Input Pinion

2. Install bearing cup (C) using a 78 mm (3-5/64 in.) disk. Install cup tight against shoulder in quill.

3. Install bearing cup (B) using a 74 mm (2-29/32 in.) disk. Install cup tight against shoulder in quill.

4. Install bearing (A).

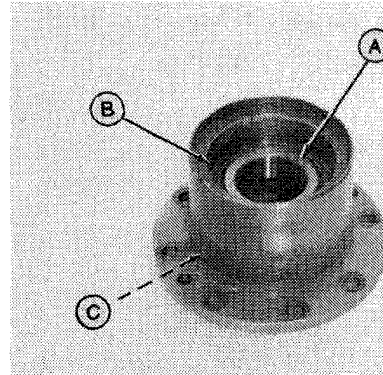

0210,19 -19-20APR90

T6439MA
-JUN-18OCT88

5. Install pinion shaft (A).

6. Install input flange (B).

7. Install original shim pack (C), spacer (D), and cap screw (E). Tighten cap screw to 180 N·m (80 lb-ft).

NOTE: Do not install oil seal at this time. Oil seal will be installed after pinion shaft adjustment.

A—Pinion Shaft	D—Spacer
B—Input Flange	E—Cap Screw
C—Shim Pack	

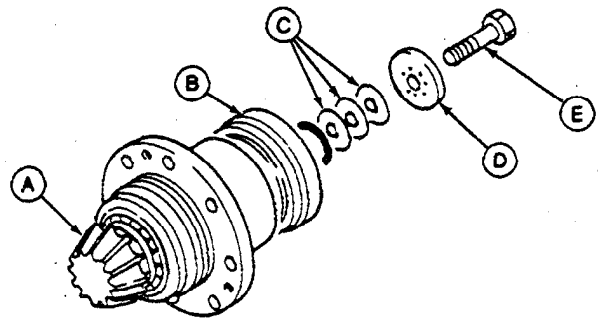

0210,20 -19-20APR90

T6439MC
-JUN-19MAY89

8. Check rolling drag torque to be within 15—18 N·m (11—13 lb-ft). Add shims to decrease or subtract shims to increase rolling drag torque.

9. Check to make sure there is no end play in the pinion shaft bearings.

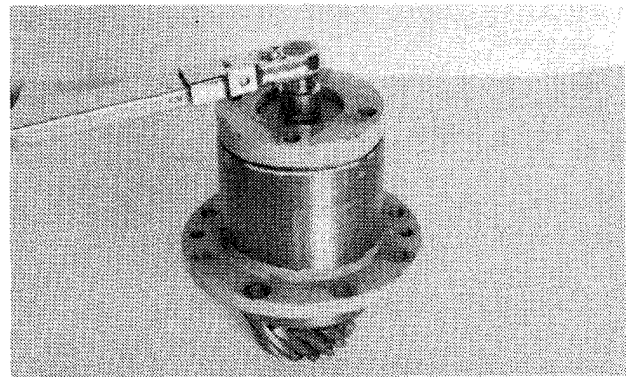

0210,21 -19-20APR90

T6439MD
-JUN-18OCT88

Differential or Bevel Drive/Input Pinion

10. Remove cap screw (A), spacer (B), shims (C), and input flange (D).

A—Cap Screw
B—Spacer

C—Shim Pack
D—Input Flange

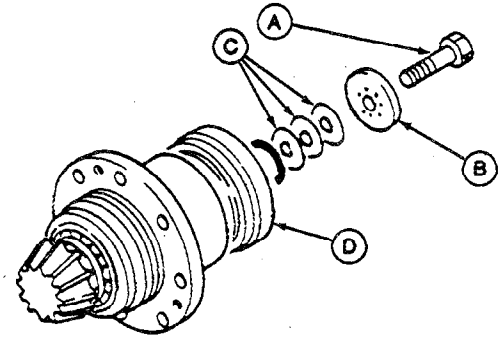

0210,22 -19-20APR90

T6439ME -JUN-19MAY89

11. Apply thread lock and sealer (medium strength) or an equivalent, on the outside surface of the oil seal (A).

12. Install new oil seal (A) using an 81 mm (3-3/16 in.) disk. Put multipurpose grease on seal lips.

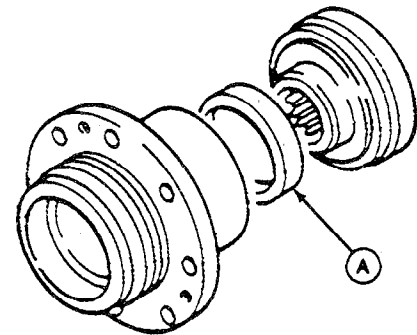

0210,23 -19-20APR90

T6439MF -JUN-19MAY89

13. Install input flange.

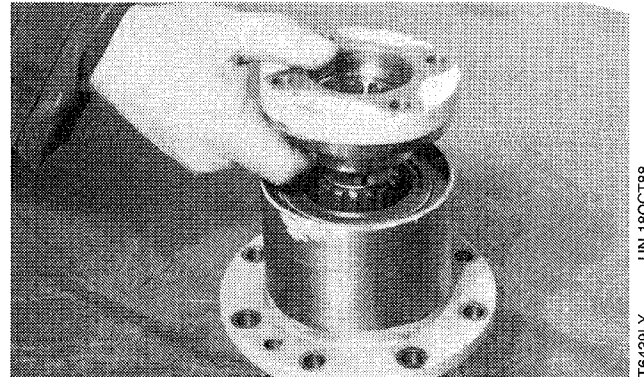

0210,24 -19-20APR90

T6439LY -JUN-18OCT88

14. Install O-rings (A and B).

15. Install shims (C), spacer (D), and cap screw (E). Tighten cap screws to 108 N·m (80 lb-ft).

16. Install cotter pin (F) and spring pin (G). Bend ends of cotter pin around spring pin.

A—O-Ring
B—O-Ring
C—Shim Pack
D—Spacer

E—Cap Screw
F—Cotter Pin
G—Spring Pin

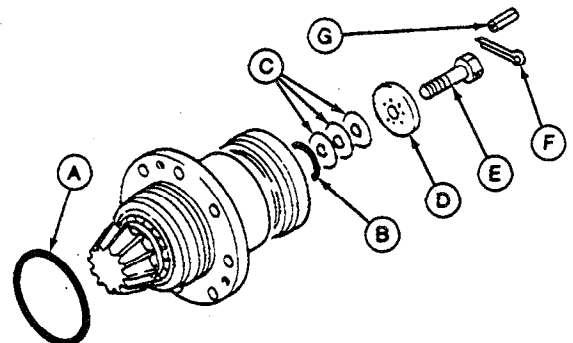

0210,25 -19-20APR90

T6439MG -JUN-19MAY89

INSTALL DIFFERENTIAL AND INPUT PINION

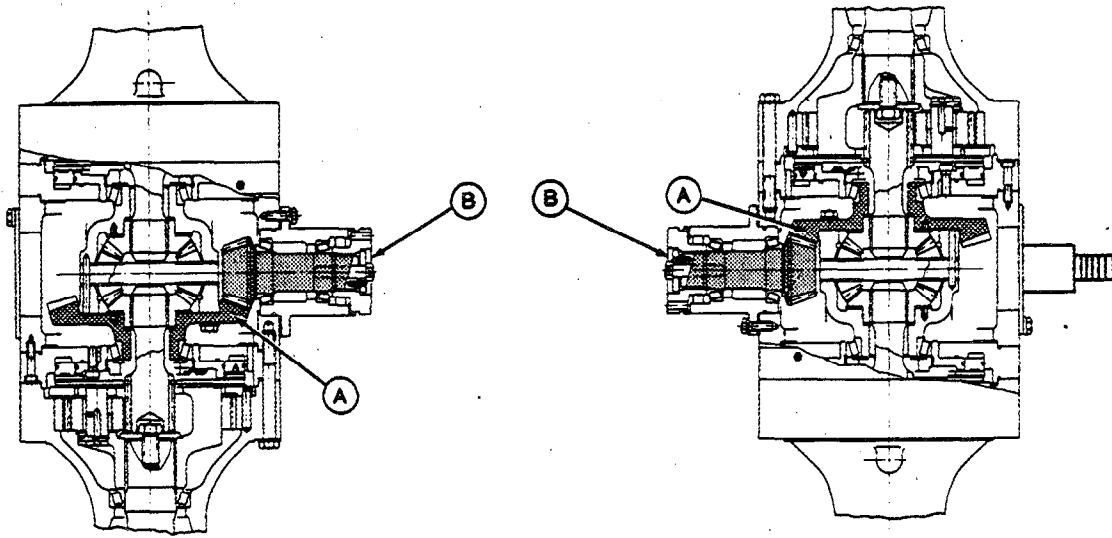

T6439MI -UN-19MAY89

1. Install differential. The ring gear (A) will be on the left side when facing the input pinion (B).

0210,27 -19-20APR90

2. Coat O-rings with hydraulic oil. Install O-rings.

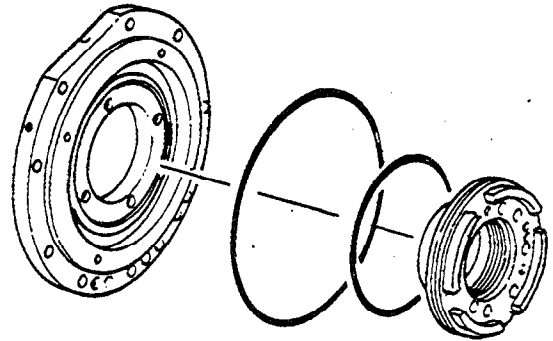

T6439LP -UN-19MAY89

0210,28 -19-20APR90

Differential or Bevel Drive/Input Pinion

3. Install brake piston housing. Apply thread lock and sealer (medium strength) to the cap screw threads (A). Tighten to 30 N·m (22 lb-ft) torque.

4. Install carriers (B) and bearing cup (C). Apply thread lock and sealer (medium strength) to the cap screw threads. Tighten to 59 N·m (44 lb-ft) torque.

5. Install adjusting nuts (D).

6. Install brake line.

A—Cap Screw
B—Carrier

C—Bearing Cup
D—Adjusting Nut

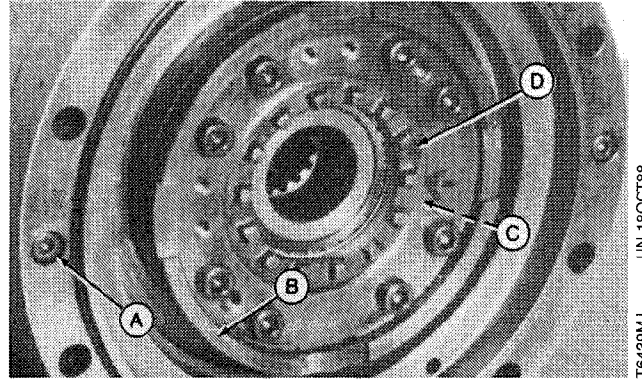

0210,29 -19-20APR90

7. Measure amount of effort to turn differential housing using a spring scale and string. Reading on scale must be 2.2—2.75 kg (4.8—6.1 lb). To increase or decrease amount of pull, loosen or tighten adjusting nut.

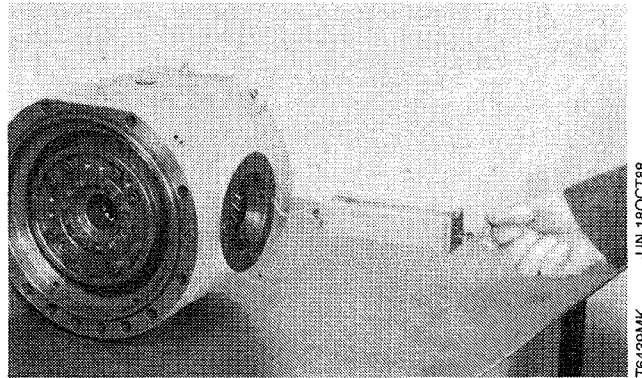

0210,32 -19-20APR90

8. Install original shim Pack.

9. Install input pinion.

10. Tighten cap screws (A) to 59 N·m (44 lb-ft) torque.

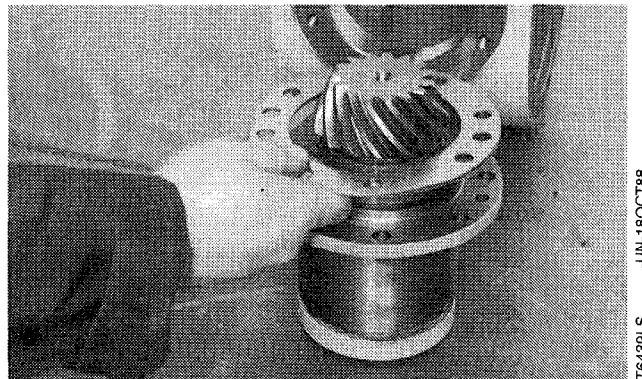

0210,26 -19-20APR90



Suggest:

If the above button click is invalid.

Please download this document

first, and then click the above link

to download the complete manual.

Thank you so much for reading

11. Position dial indicator with contact point resting against ring gear tooth.

12. Hold pinion shaft stationary. Move ring gear back and forth. Measure backlash.

BACKLASH SPECIFICATION

Backlash 0.15—0.20 mm
(0.006—0.008 in.)

13. Adjust backlash by turning both differential adjusting nuts an equal amount in the same direction to move the differential closer to or farther away from the input pinion.

14. Apply dye on several teeth of ring gear drive side (convex).

15. Hold ring gear just tight enough to create resistance. Turn input pinion flange so that pinion shaft teeth contact drive side of ring gear teeth. Turn ring gear one complete revolution.

16. Check tooth pattern on ring gear.

17. Make adjustments indicated in chart.

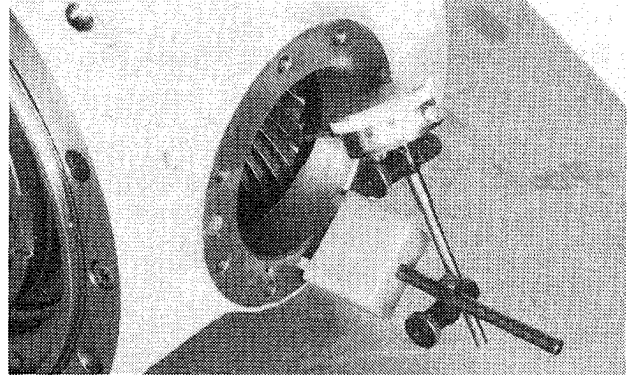

T6439ML JUN-18OCT88

<https://www.ebooklibonline.com>

Hello dear friend!

Thank you very much for reading.

Enter the link into your browser.

The full manual is available for immediate download.

<https://www.ebooklibonline.com>