



Service Repair Manual

Models

D8L TRACK-TYPE
TRACTOR Dozer

Previous Screen

Product: TRACK-TYPE TRACTOR

Model: D8L TRACK-TYPE TRACTOR 7JC

Configuration: D8L TRACTOR / POWER SHIFT / 7JC00001-UP (MACHINE) POWERED BY 3408 ENGINE

**Disassembly and Assembly
D8L TRACTOR POWER TRAIN**

Media Number -SEN2338-01

Publication Date -01/10/1986

Date Updated -06/03/2018

SEN23380028

Torque Divider

SMCS - 3113-016; 3113-010; 3113-015

Remove And Install Torque Divider

Tools Needed		A
6V2157	Link Bracket	2

Start By:

- a. remove main drive shaft
- b. remove torque converter outlet relief valve

NOTE: The pump coupling group was removed for photo illustration.

1. Drain the oil from the torque divider.

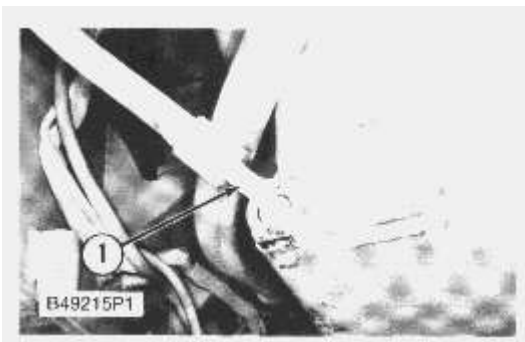

2. Disconnect oil line (1) from the torque divider cover.

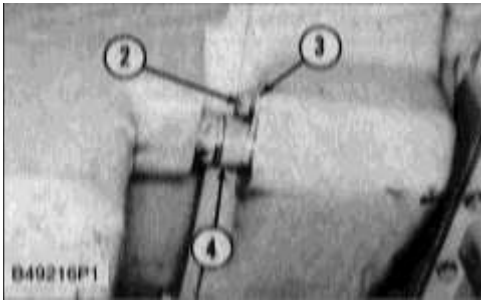

3. Remove bolt (2) and lock (3) that holds tube (4) in place. Slide tube (4) into the torque divider cover.

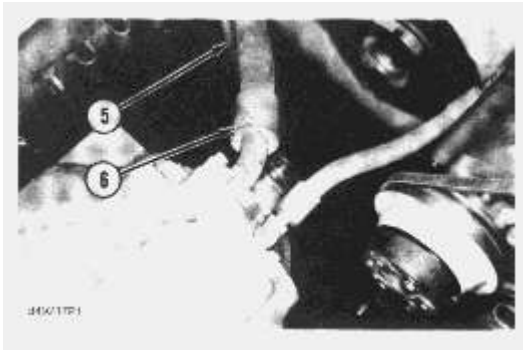

4. Disconnect oil line (5).

5. Disconnect oil lines (6) and (7) from the torque divider.

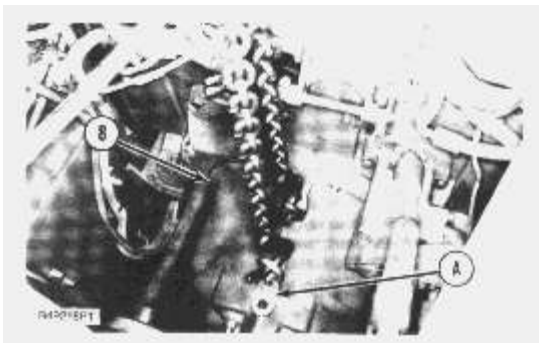

6. Put a hoist in position through the door of the cab.

7. Fasten tooling (A) to the torque divider and the hoist.

8. Remove bolts (8) that hold the torque divider to the flywheel housing.

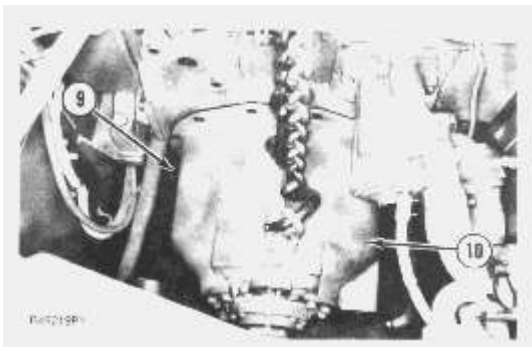

<https://www.ebooklibonline.com>

Hello dear friend!

Thank you very much for reading.

Enter the link into your browser.

The full manual is available for immediate download.

<https://www.ebooklibonline.com>

9. Install two 1/2" - 13 NC forcing screws (9) in the torque divider cover. Tighten the forcing screws evenly and make a separation of the torque divider from the flywheel housing.

10. Lower torque divider (10) to the ground. The weight is 350 Kg (772 lb.).

11. Remove the torque divider from under the machine.

NOTE: The following steps are for installation of the torque divider.

12. Make sure the O-ring seal is in position on the front of the torque divider cover.

13. Make sure the O-ring seals are in position on tube (4). Make sure tube (4) is in the torque divider before it is put in position.

14. Install tooling (A) on torque divider (10). Slide the torque divider in position under the machine. Fasten a hoist to tooling (A).

15. Install two 1/2" - 13 NC × 4 in. long guide bolts in the flywheel housing.

16. Lift torque divider (10) up and put it in position on the flywheel housing. Make an alignment of the splines in the flywheel and the splines of the torque divider. Slide torque divider (10) against the flywheel housing.

17. Install bolts (8) that hold the torque divider to the flywheel housing. Remove tooling (A).

18. Connect oil line (5).

19. Connect oil lines (6) and (7) to the torque divider.

20. Slide tube (4) into the flywheel housing.

21. Install lock (3) and bolt (2) that holds tube (4) in place.

22. Connect oil line (1) to the torque divider cover.

End By:

a. install torque converter outlet relief valve

b. install main drive shaft

Disassemble Torque Divider

Tools Needed		A	B	C	D	E
1P1864	Retaining Ring Pliers	1				
5P9736	Link Bracket		2			
1P820	Hydraulic Puller Group			1		
6V9061	Manual Pump Group (or electric)			1		
1P4207	Nuts			2		
3H465	Bracket			4		
8B7549	Leg			2		
5F7342	Adapter			2		
5F7343	Bearing Pulling Attachment			1		
1P520	Driver Group			1		1
FT553	Adapter				1	

Start By:

- a. remove torque divider

NOTICE

When a torque converter or divider has a failure, the complete oil system for the torque converter, torque divider and transmission must be thoroughly cleaned. Any foreign material which is not removed from the oil system for the torque converter will move through the hydraulic system for the transmission.

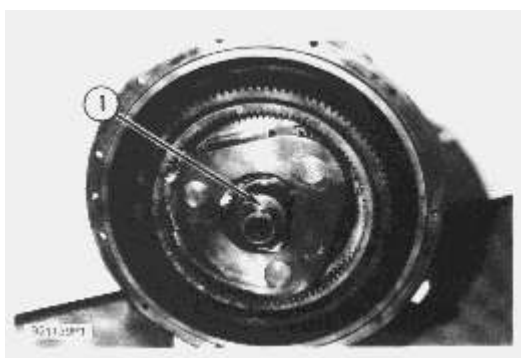

1. Use tool (A) to remove snap ring (1) from the shaft.

7. Remove the pins from shafts (9).

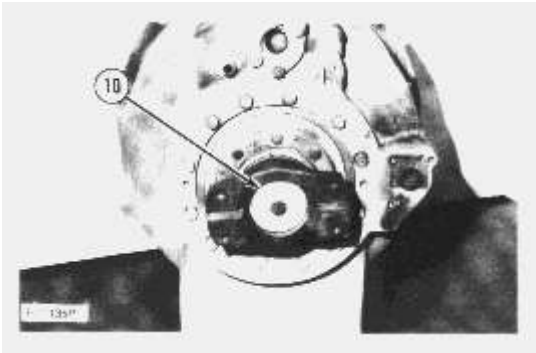

8. Remove the bolt, retainer (10) and the O-ring seal.

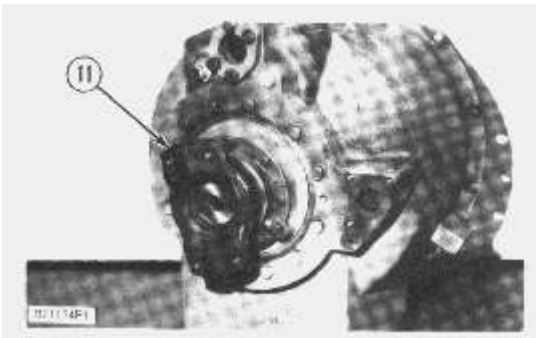

9. Remove yoke (11) from the housing.

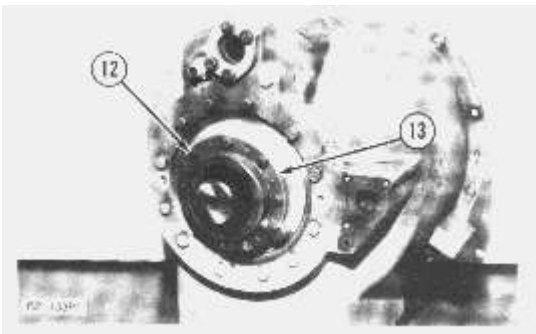

10. Remove bolts (12) and retainer (13) from the torque divider.

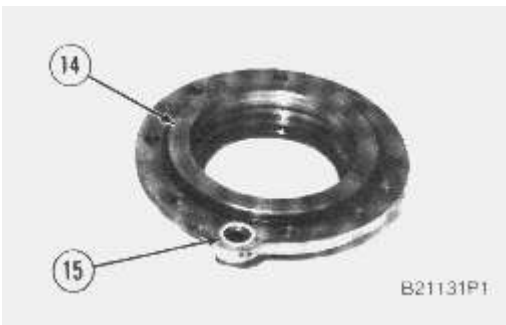

11. Remove O-ring seals (14) and (15) from the retainer.

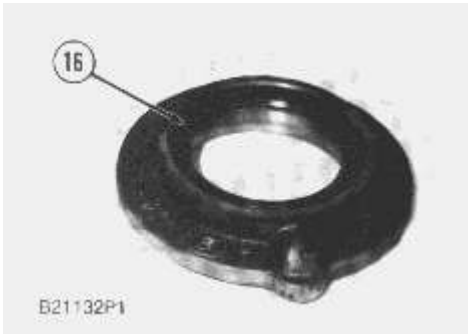

12. Remove lip-type seal (16) from the retainer.

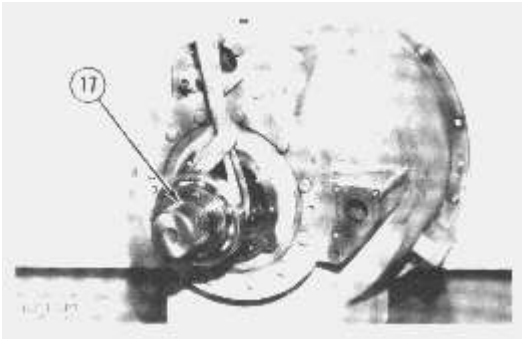

13. Move shaft assembly (17) out far enough to fasten a hoist to it. Fasten a hoist to the shaft assembly, and remove it. The weight of the shaft assembly is 23 Kg (50 lb.).

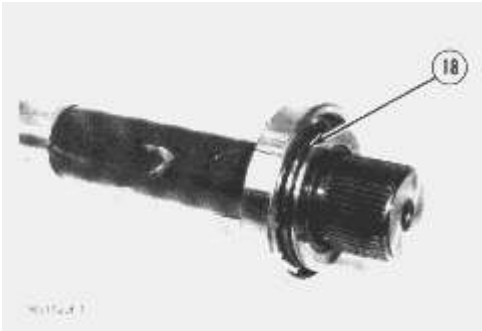

14. Remove seal ring (18) from the seal carrier.

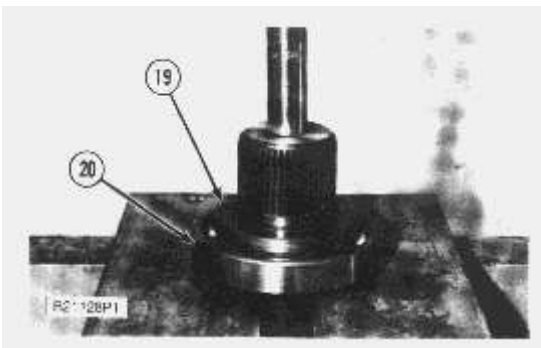

NOTE: On later torque dividers, the inside race of bearing (20) is a split race.

15. Put the shaft assembly in position in a press, and remove seal carrier (19) and bearing (20).

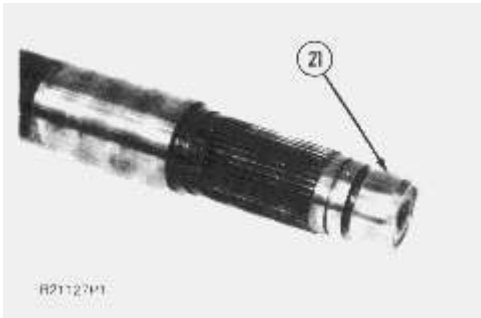

16. Remove bearing race (21) from the shaft if necessary.

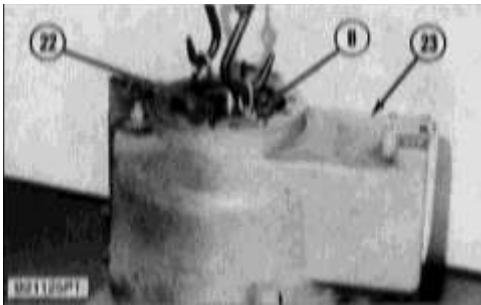

17. Put the torque divider in position as shown.

18. Remove the bolts that hold case (23) to the torque divider.

19. Install two 1/2" - 13 NC forcing screws (22) in the cover. Install tooling (B), and remove case (23). The weight of the case is 104 Kg (230 lb.).



20. Remove two O-ring seals (24) from the support.

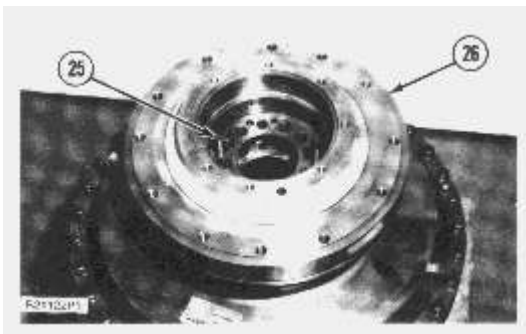

21. Install two 3/8" - 16 NC forcing screws (25) in support (26). Remove support (26) from the torque divider.

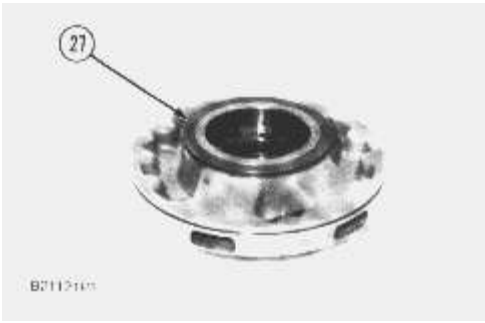

NOTE: Do not remove plate (27) unless the support or the plate are to be replaced.

22. Remove plate (27) from the support.

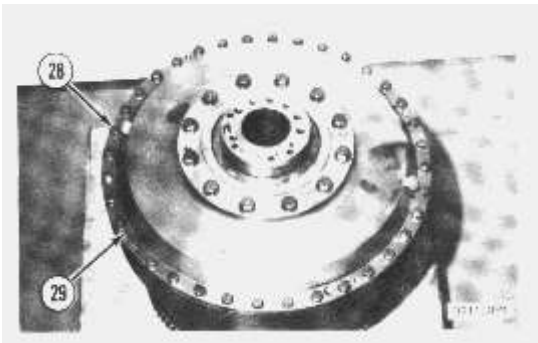

23. Remove bolts (28) that hold flange assembly (29).

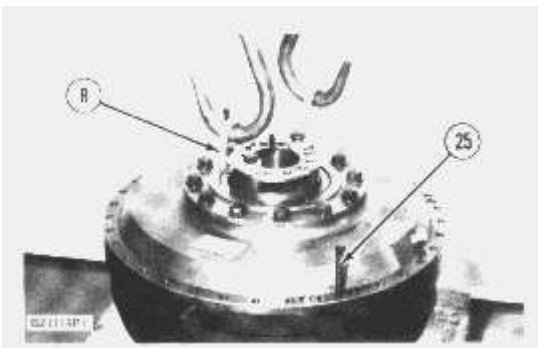

24. Install tooling (B) on the carrier. Install two 3/8" - 16 NC forcing screws (25), and remove the flange assembly. The weight of the flange assembly is 54 Kg (120 lb.).

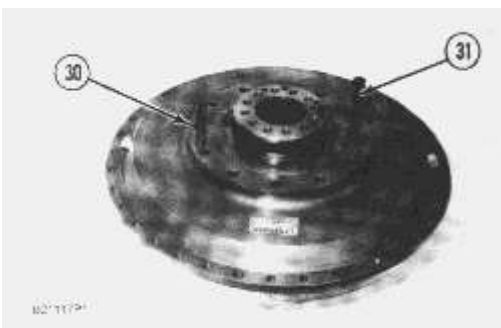

25. Remove the bolts that hold sleeve (30) in place. Install two 1/2" - 13 NC bolts (31) in the threaded holes. Remove sleeve (30).

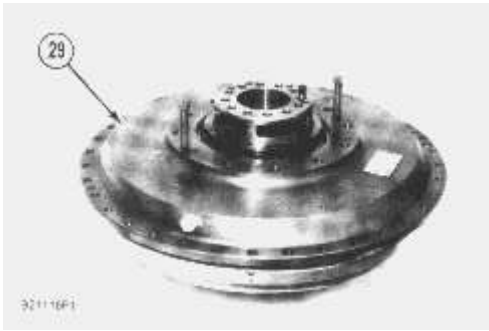

26. Install two 1/2" - 13 NC forcing screws, and remove flange assembly (29) from the impeller.

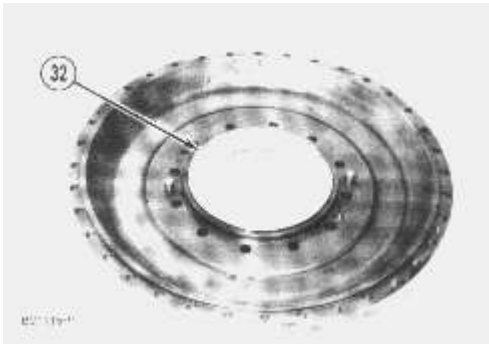

27. Remove bearing race (32) from the flange.

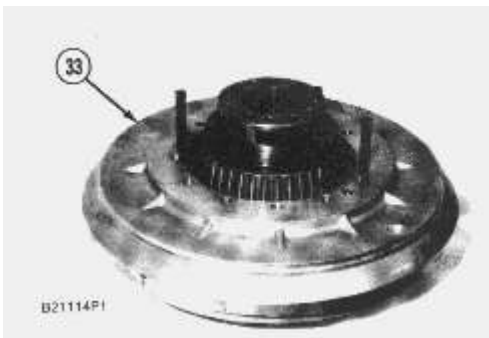

28. Install two 1/2" - 13 NC forcing screws, and remove impeller (33) from the carrier assembly.

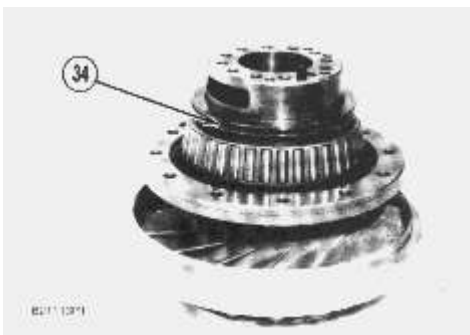

29. Remove seal ring (34) from the seal carrier.

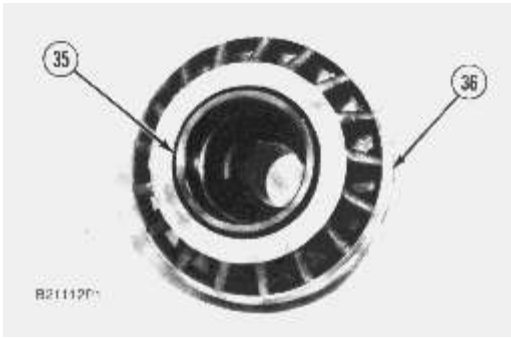

30. Remove spiral retainer ring (35) from the carrier.

31. Heat carrier and stator (36) to a maximum temperature of 149° C (300° F).

32. Remove stator (36) from the carrier.

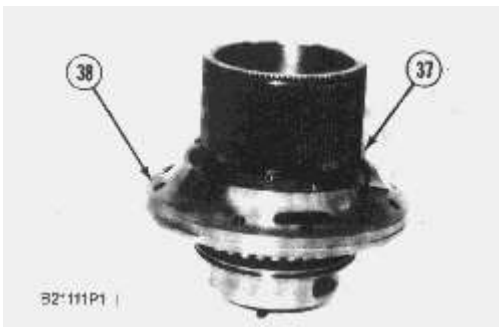

33. Remove spiral ring (37) and hub (38) from the carrier.

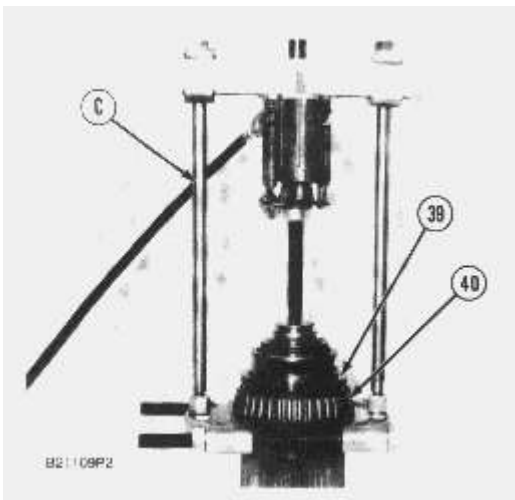

34. Push the pin that holds seal carrier (39) to the carrier out of the carrier. Install tool (C) on the carrier as shown. Remove seal carrier (39) and bearing cone (40).

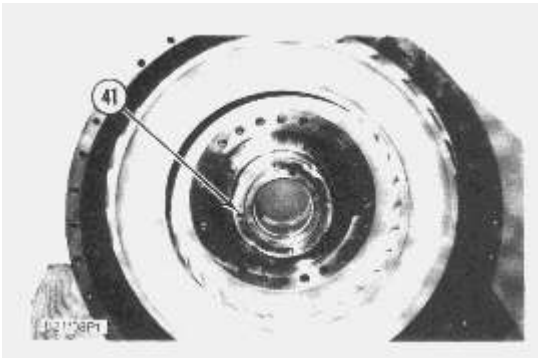

NOTICE

Setscrew (41) must be removed from the spanner nut before the nut is loosened.

35. Remove setscrew (41) from the nut.

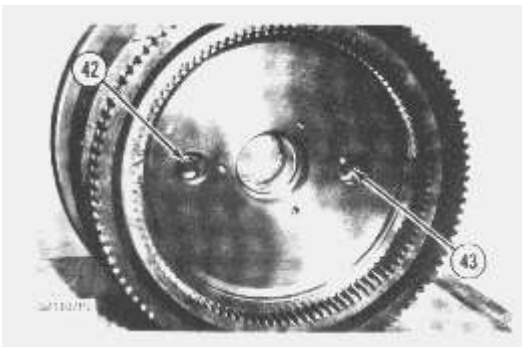

36. Make an alignment of the holes in the flange assembly with bolts (42) and (43), and remove the bolts.

37. Install two spacers that are 3/8" I.D. \times 3/4" O.D. \times 1" long and two 0S1571 3/8" - 16 NC \times 1 3/4" bolts in the bolt holes to hold the flange assembly in place when nut (44) is removed.

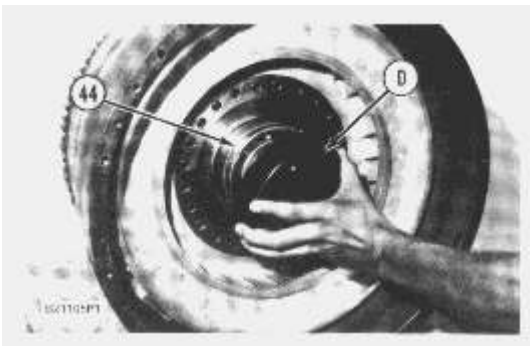

38. Put tool (D) in place, and install two 5/16" - 18 NC \times 1 in. long bolts to hold tool (D) to the nut.

39. Remove nut (44) and the washer.

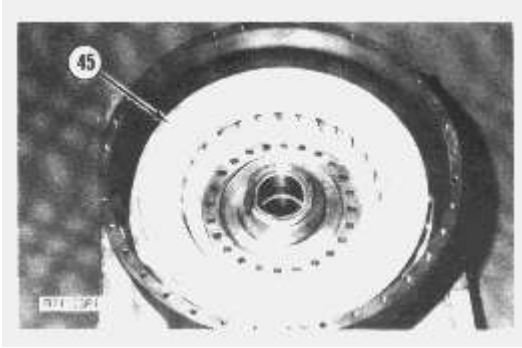

40. Remove turbine assembly (45) from the housing.

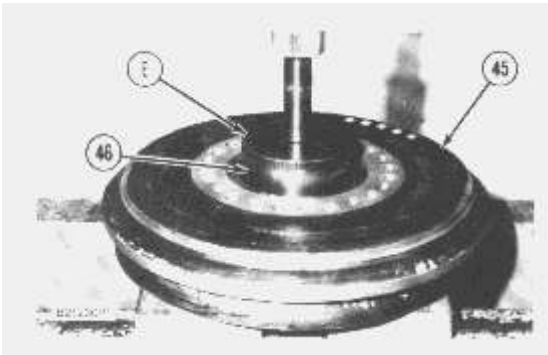

41. Remove the bolts that hold the turbine to the hub.

42. Put turbine assembly (45) in position in a press. Use tool (E) to remove the turbine from hub (46).

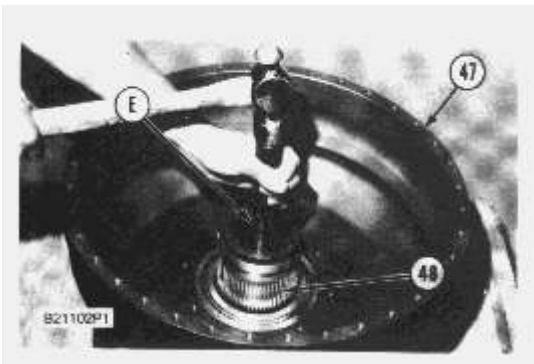

43. Put housing (47) in position on wooden blocks.

44. Use tool (E) to push flange assembly (48) out of the housing.

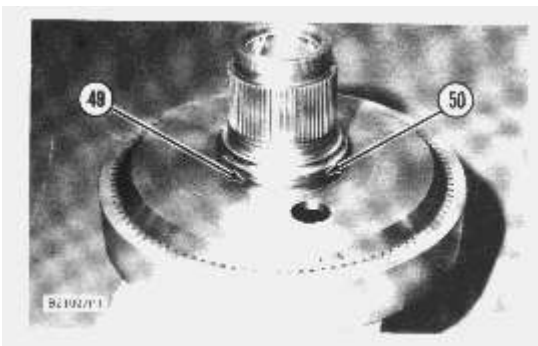

45. Remove seal ring (49) from carrier (50).

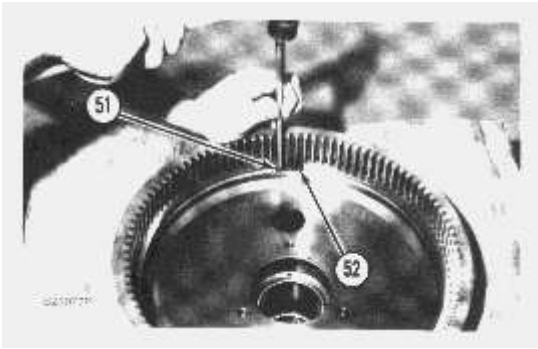

46. Push pins (51) down with a hammer and punch.

47. Remove ring (52) and the ring gear from the flange.



48. Install three 3/8" - 16 NC forcing screws (53), and remove bearing race (54) and seal carrier (50).

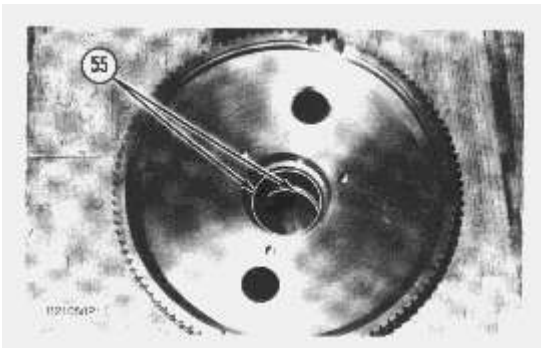

49. Use tool (E) to remove bearings (55) if replacements must be made.

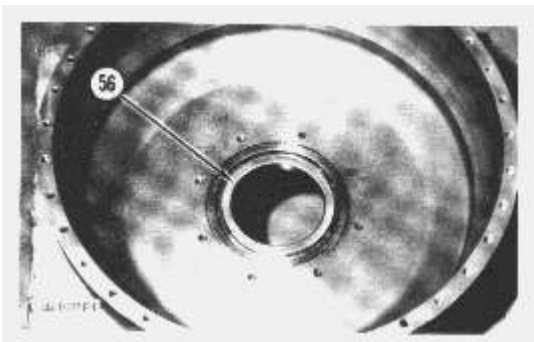

50. Remove bearing race (56) from the housing.

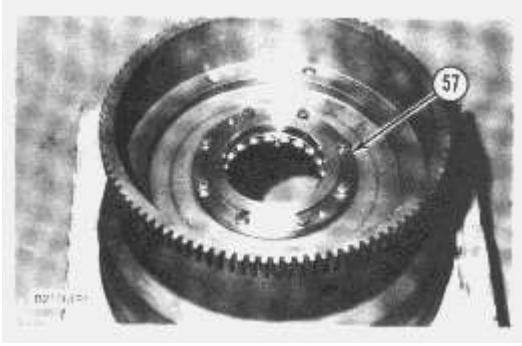

51. Remove the bolts and retainer (57) from the torque divider housing.

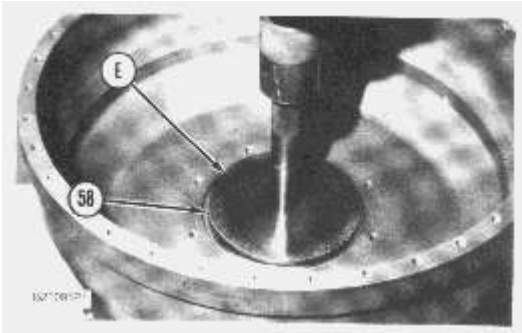

52. Put the housing in position in a press. Use tool (E) to remove bearing (58) from the housing.

Assemble Torque Divider

Tools Needed		A	B	E	F
1P1864	Retaining Ring Pliers	1			
5P9736	Link Bracket		2		
1P520	Driver Group			1	
FT553	Adapter				1
0S1618	Bolt [5/16" - 18 NC x 1 in. (25.4 mm) long]				2
6V4085	Torque Multiplier				1

1. Inspect all parts for wear or damage. Make a replacement if necessary.

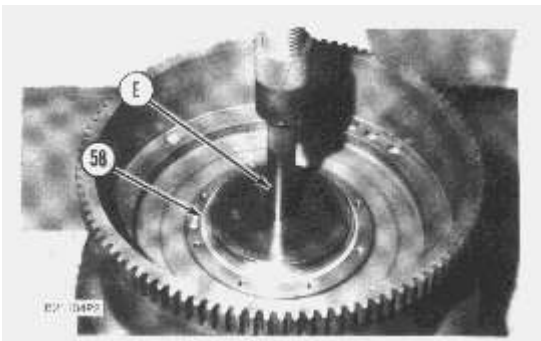

2. Make sure the ring is in position in the outside bearing race. Use tool (E) to install bearing (58) in the housing until the ring makes contact with the surface of the housing.

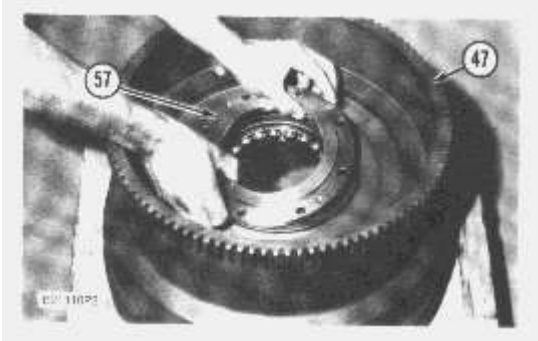

3. Install the top bearing race and bearing retainer (57) in housing (47). Install the bolts that hold the retainer in place. Tighten the bolts to a torque of 50 ± 3 N·m (37 ± 2 lb.ft.).

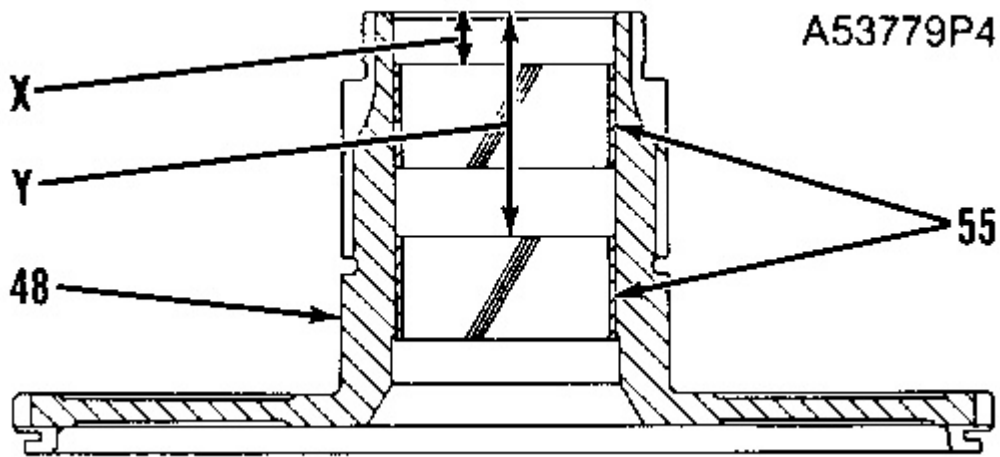

4. Install bearings (55) in flange (48) with tooling (E) and a press. Dimension (X) must be 9.00 mm (.354 in.). Dimension (Y) must be 76.0 mm (2.992 in.).

5. The inside diameter of bearings (55) must be 69.939 ± 0.044 mm (2.7535 ± 0.0017 in.) after assembly.

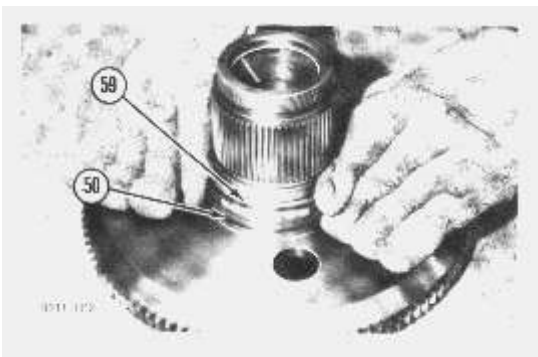

6. Heat seal carrier (50) and bearing race (59) to a maximum temperature of 150° C (302° F). Install the seal carrier and bearing race on the flange.

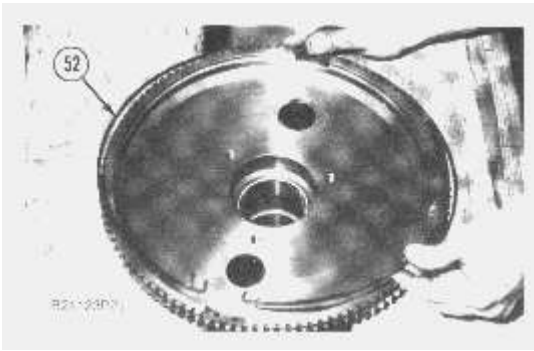

7. Put ring (52) in position in the groove of flange (5).



8. Install ring gear (60) on the flange assembly. Make sure ring (52) is in alignment with the groove in the ring gear. Install the two pins that hold the ring in place.

9. Install seal ring (49) on the seal carrier.

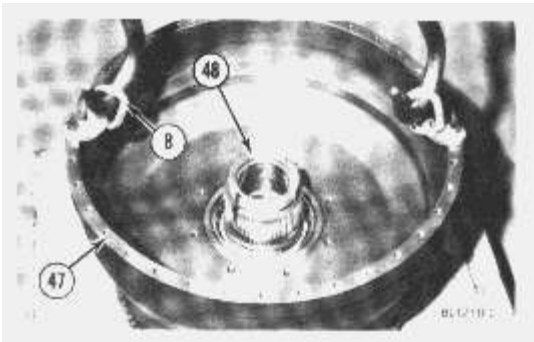

10. Install tooling (B) on the housing. Lower housing (47) onto flange (48).

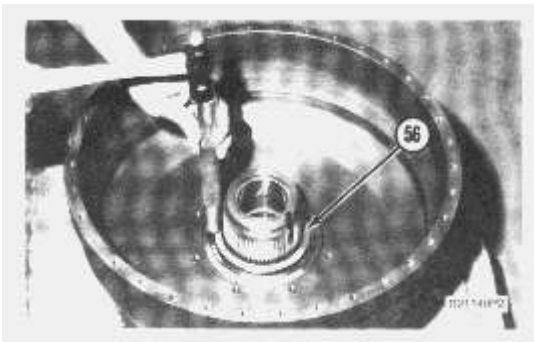

11. Install bearing race (56) with a hammer and a brass punch.

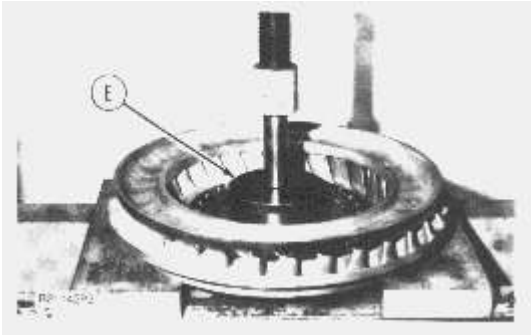
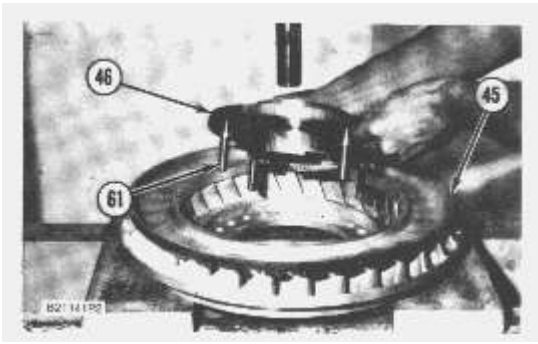

12. Install guide bolts (61) in hub (46).

13. Use a press and tooling (E) to install hub (46) in turbine (45). Install the bolts that hold the turbine to the hub. Tighten the bolts to a torque of $110 \pm 5 \text{ N}\cdot\text{m}$ ($80 \pm 4 \text{ lb}\cdot\text{ft.}$).

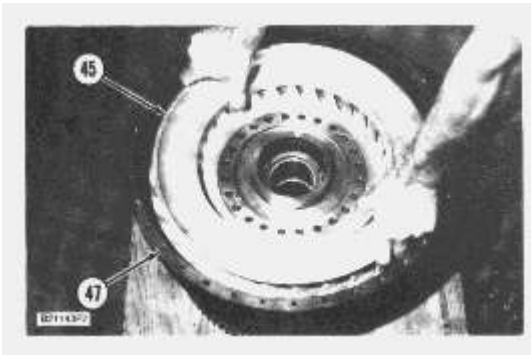

14. Install turbine assembly (45) into housing (47). Align the spline on the hub with the splines on the flange assembly.

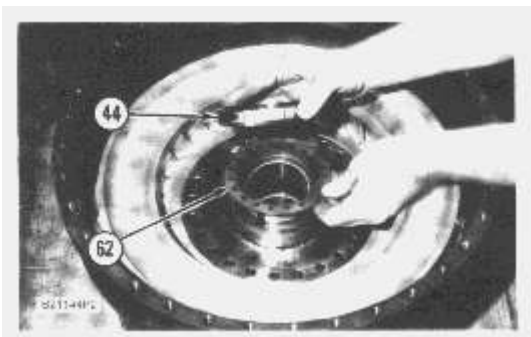

15. Put clean SAE 30 oil on the flange threads, the washer and the nut before the washer and nut are installed. Install washer (62) and spanner nut (44). Align the grooves (slots) in the flange with teeth in the washer.

21. Install spiral ring (37) on the carrier.
22. Put hub (38) in position on the carrier.

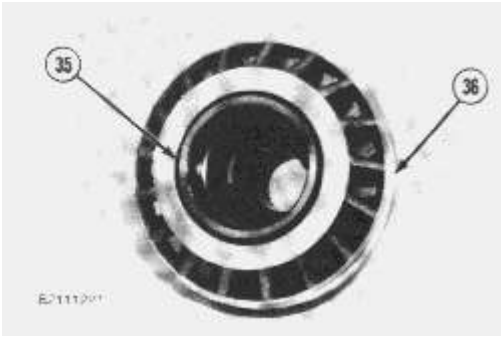

23. Heat stator (36) to a maximum temperature of 150° C (302° F). Install the stator on the carrier. Align the splines in the stator with the splines on the carrier.
24. Install spiral ring (35) on the carrier.

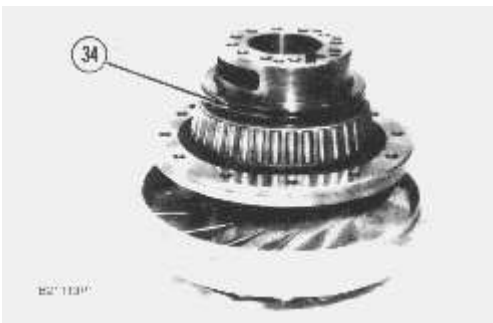

25. Install seal ring (34) in the groove in the seal carrier.



26. Install two guide bolts (64) 1/2" - 13 NC in the hub. Install impeller (33) on the hub.

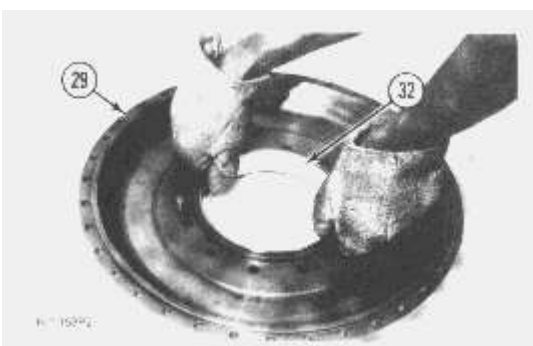

27. Lower the temperature of bearing cup (32), and install it in flange (29).

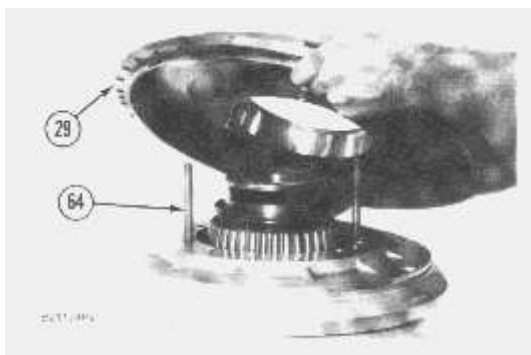

28. Install two 1/2" - 13 NC guide bolts (64) in the impeller. Put flange assembly (29) in position.

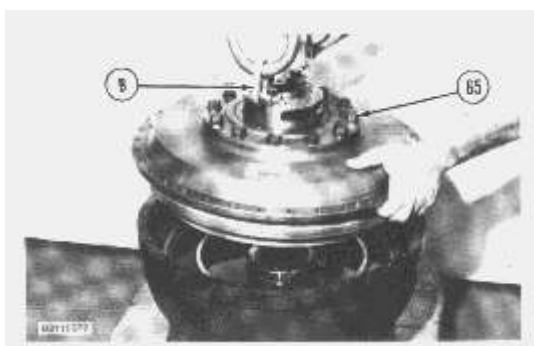

29. Put sleeve (30) in position on the flange assembly. Install bolts (65) that hold the sleeve, flange assembly and impeller together. Tighten the bolts to a torque of 110 ± 5 N·m (81 ± 4 lb.ft.).

30. Put tooling (B) in position on the carrier assembly.

31. Lower the carrier assembly into position on the housing.

32. Install the bolts that hold the flange assembly to the housing. Tighten the bolts to a torque of 50 ± 3 N·m (37 ± 2 lb.ft.).

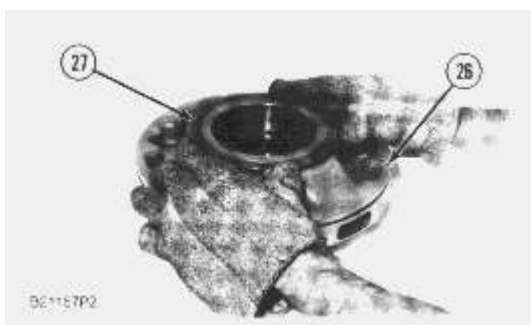

33. If plate (27) was removed from the support, heat plate (27) to a maximum temperature of 150° C (302° F). Install the plate on support (26).

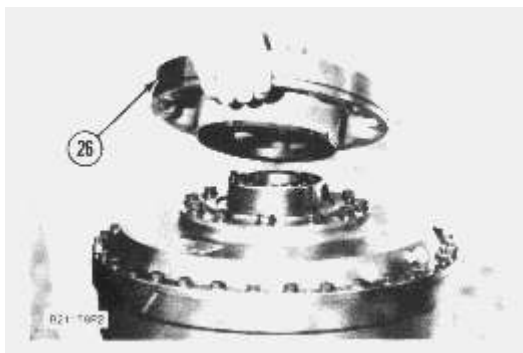

34. Put support (26) in position on the carrier assembly. Make an alignment of the holes in the carrier with the pins in the support. Install the bolts that hold the support to the carrier. Tighten the bolts to a torque of $110 \pm 5 \text{ N}\cdot\text{m}$ ($80 \pm 4 \text{ lb}\cdot\text{ft}$).

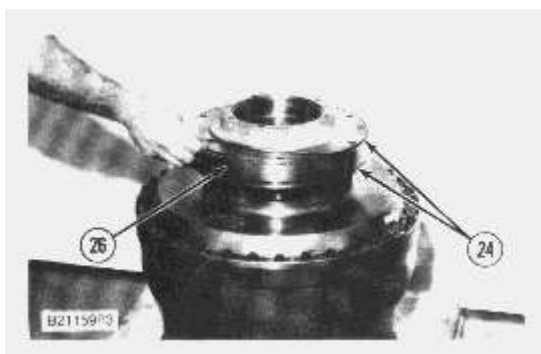

35. Put one O-ring seal (24) in position in the groove in support (26).

36. Install the other O-ring seal (24) on top of support (26) as follows:

- a.** Put the O-ring seal over both hands. Stretch the seal until there is approximately 508 to 610 mm (20 to 24 in.) between the hands.
- b.** Install the O-ring seal in the rear groove of support (26).
- c.** Put a light layer of 2S3230 Bearing Lubricant on the O-ring seal to hold it in place.

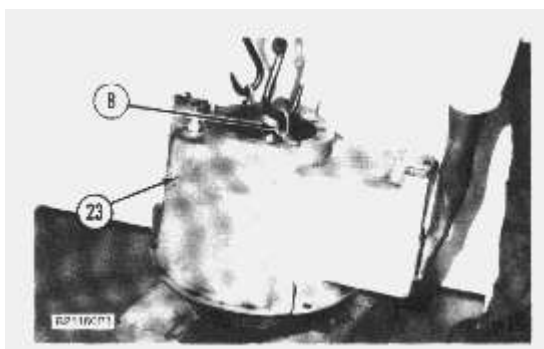

37. Fasten a hoist and tooling (B) to case (23). Align the holes in the case with the holes in the support. Lower case (23) into position, and install the bolts that hold it.



Suggest:

If the above button click is invalid.

Please download this document

first, and then click the above link

to download the complete manual.

Thank you so much for reading

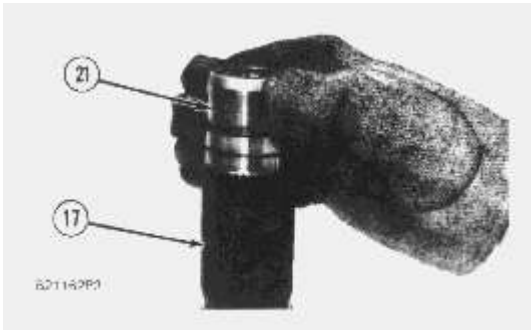

38. Heat bearing race (21) to a maximum temperature of 135° C (275° F), and install it on shaft (17) with the tapered end of the bearing toward the end of the shaft.

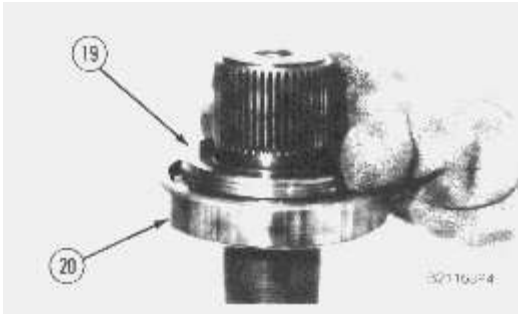

NOTE: On later torque dividers, bearing (20) is a split race bearing.

39. Heat bearing (20) and seal carrier (19) to a maximum temperature of 135° C (275° F), and install them on the shaft.

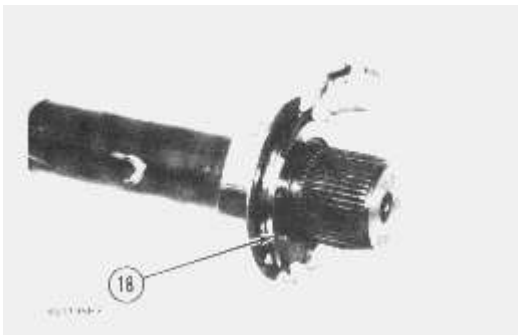

40. Put seal ring (18) in position on the seal carrier.

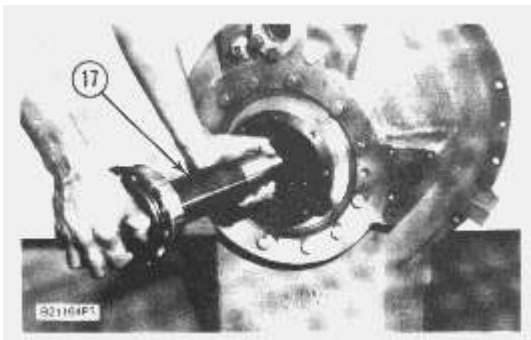

41. Put shaft assembly (17) in position in the torque divider.

<https://www.ebooklibonline.com>

Hello dear friend!

Thank you very much for reading.

Enter the link into your browser.

The full manual is available for immediate download.

<https://www.ebooklibonline.com>