



Service Repair Manual

Models

3054C INDUSTRIAL ENGINE

[Previous Screen](#)

◀ Product: INDUSTRIAL ENGINE
 Model: 3054C INDUSTRIAL ENGINE 334
 Configuration: 3054C Industrial Engine 33400001-UP

Disassembly and Assembly 3054C Industrial Engine

Media Number -REN2433-03

Publication Date -01/11/2012

Date Updated -28/04/2017

i01913195

Fuel Injection Pump - Install - Bosch EVPE

SMCS - 1251-012

Installation Procedure

Table 1

Required Tools			
Tool	Part Number	Part Name	Qty
A	230-6284	Timing Pin (Camshaft)	1
B	230-6283	Timing Pin (Crankshaft)	1
C	9U-6198	Crankshaft Turning Tool	1

NOTICE

Keep all parts clean from contaminants.

Contaminants may cause rapid wear and shortened component life.

1. Use Tooling (C) to ensure that the No. 1 cylinder is at the top center compression stroke. Refer to Testing and Adjusting, "Fuel Injection Timing - Check".

Note: Install Tooling (A) through the camshaft gear. Install Tooling (B) through the crankshaft web.

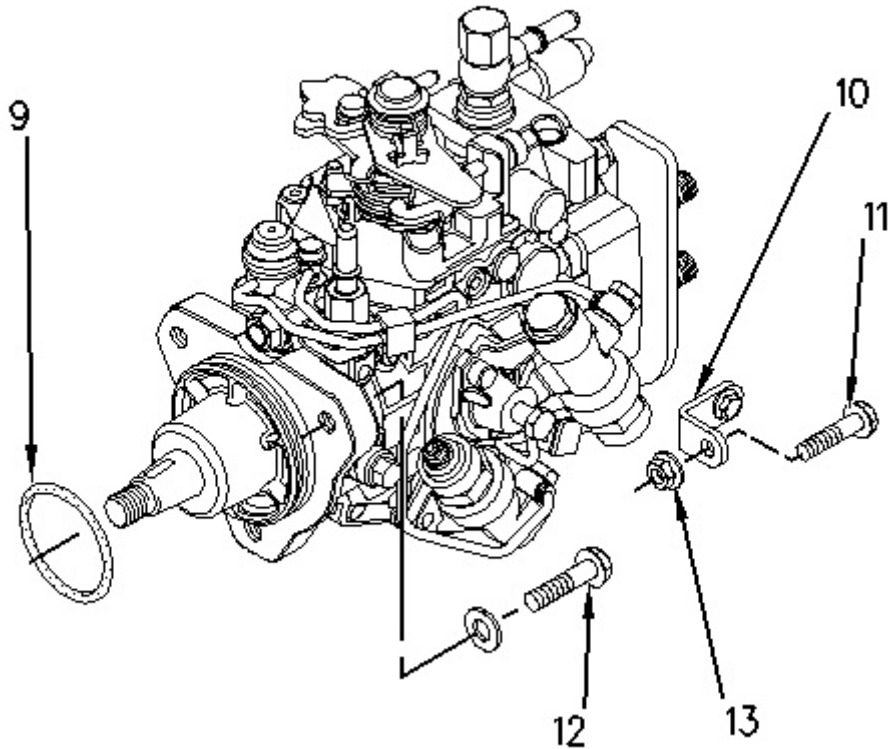

Illustration 1

g00996474

2. Install O-ring seal (9) on the fuel injection pump. Position the fuel injection pump on the front housing. Install bolts (12). Tighten the bolts to a torque of 25 N·m (18 lb ft).
3. If necessary, install the bolt and bracket (10) on the cylinder block. Tighten the bolt to a torque of 44 N·m (32 lb ft).
4. Install bolt (11) and nut (13).

Note: Ensure that the mating surfaces of the fuel injection pump gear and the shaft of the fuel injection pump are clean. Lubricate the threads of the shaft for the fuel injection pump. The nut must turn freely until contact is made with the fuel injection pump gear.

<https://www.ebooklibonline.com>

Hello dear friend!

Thank you very much for reading.

Enter the link into your browser.

The full manual is available for immediate download.

<https://www.ebooklibonline.com>

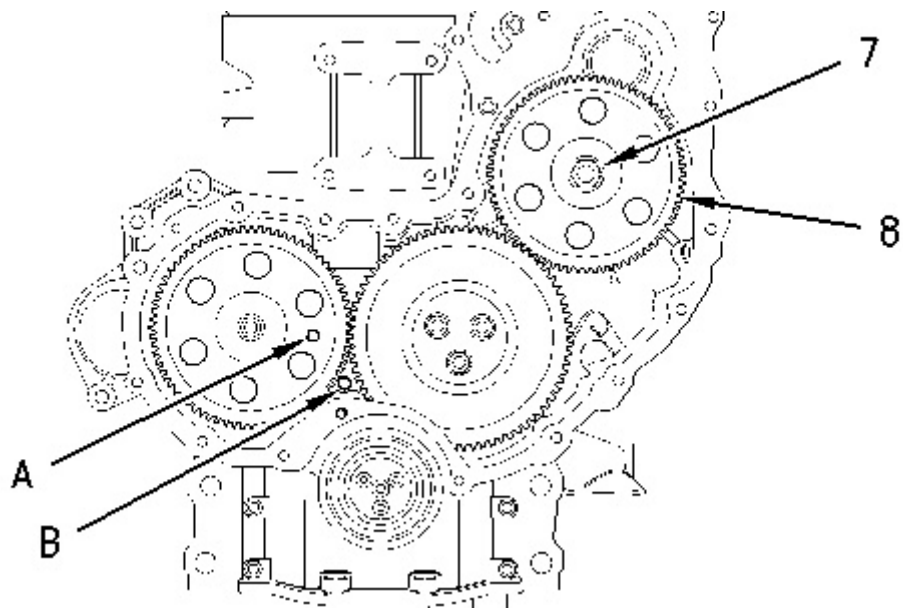

Illustration 2

g00996413

5. Position fuel injection pump gear (8) on the shaft of the fuel injection pump. Install the washer and nut (7). Rotate the fuel injection pump gear in a counterclockwise direction in order to remove the backlash. Tighten nut (7) to a torque of 24 N·m (17 lb ft).

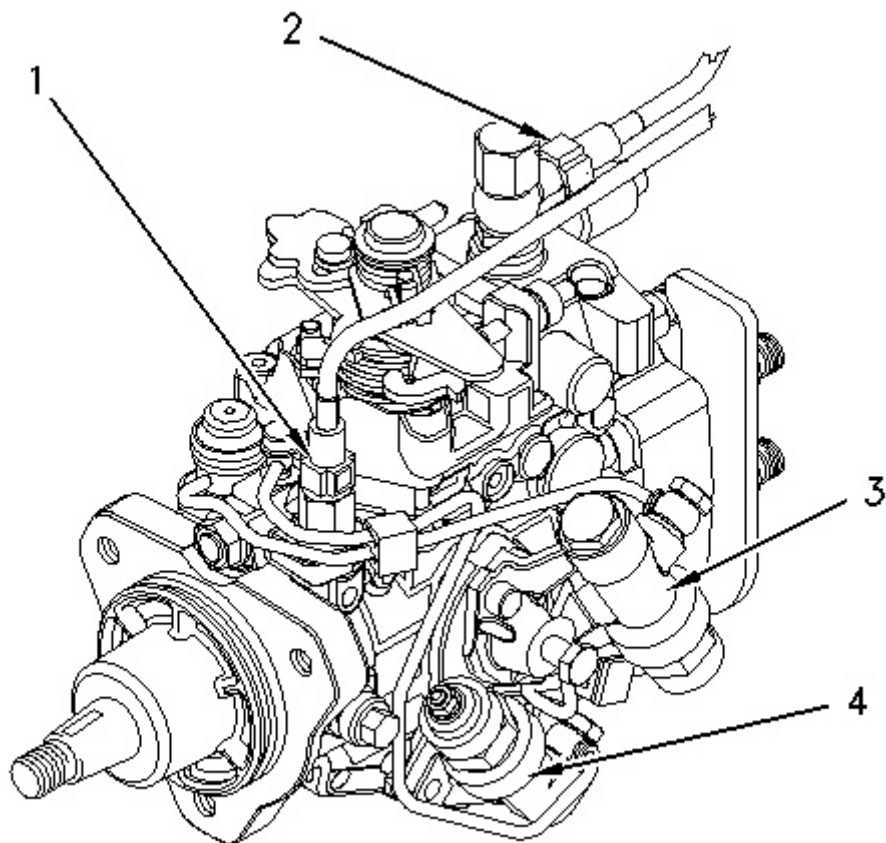

Illustration 3

g00996409

6. Connect the wiring harness assembly to engine shutoff solenoid (4).
7. Connect the wiring harness assembly to cold start advance unit (3).
8. Connect tube assembly (2) to the fuel injection pump. Connect tube assembly (1) to the fuel injection pump.

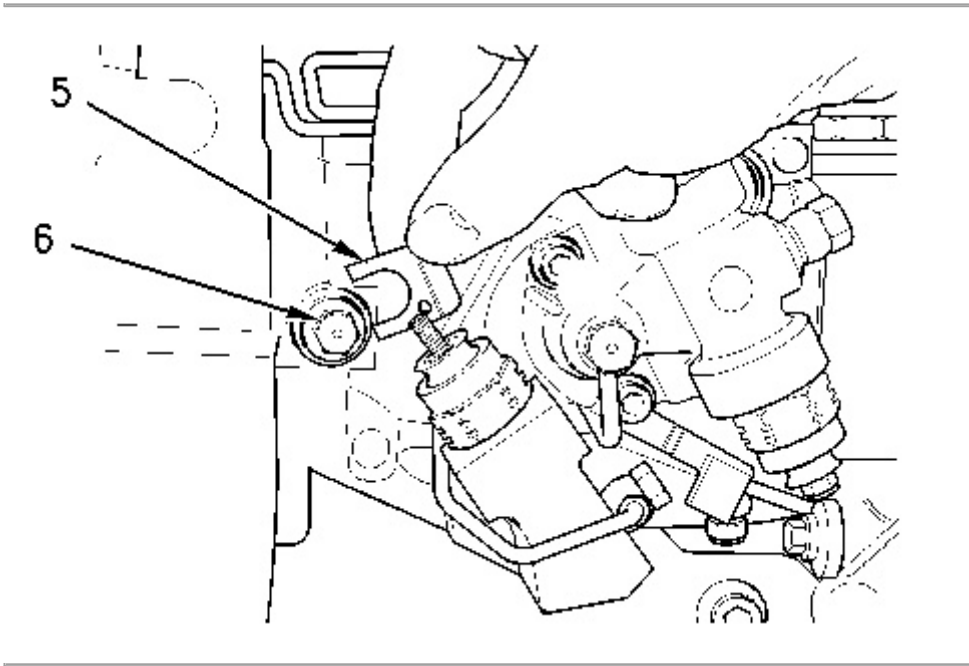

Illustration 4

g00996410

9. Loosen bolt (6). Move spacer (5) in order to prevent bolt (6) from tightening against the shaft of the fuel injection pump. Tighten bolt (6) to a torque of 12 N·m (106 lb in).

Note: Spacer (5) must be installed and bolt (6) must be tightened in order to prevent the bolt from contacting the shaft of the fuel injection pump.

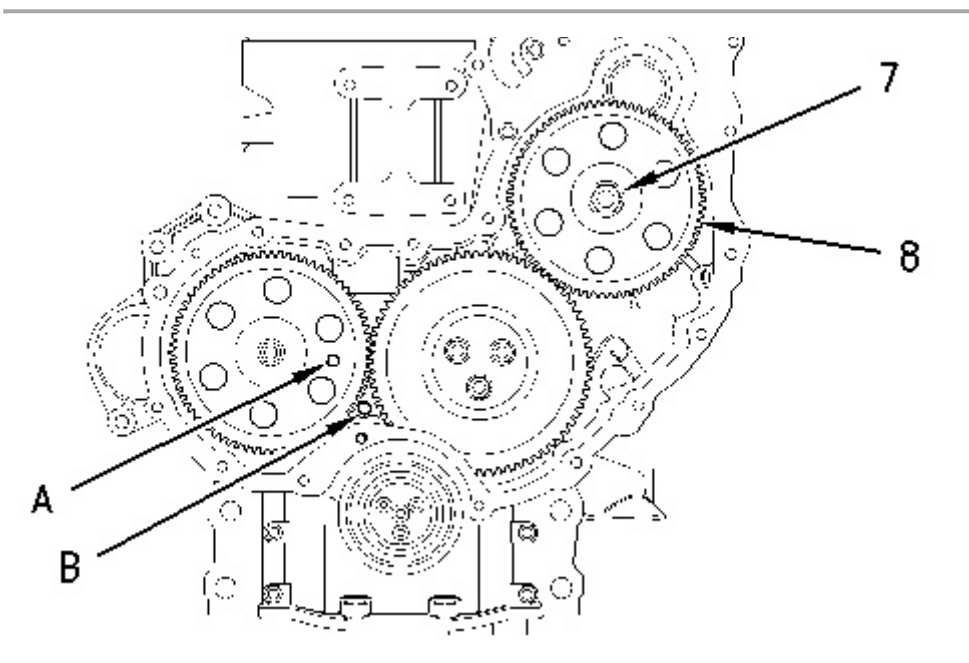

Illustration 5

g00996413

10. Tighten nut (7) to a torque of 88 N·m (65 lb ft).

11. Remove Tooling (A) and Tooling (B).

End By:

- a. Install the front cover. Refer to Disassembly and Assembly, "Front Cover - Remove and Install".
- b. Install the crankshaft pulley. Refer to Disassembly and Assembly, "Crankshaft Pulley - Remove and Install".
- c. Install the fuel injection lines. Refer to Disassembly and Assembly, "Fuel Injection Lines - Remove and Install".
- d. Install the air compressor, if equipped. Refer to Disassembly and Assembly, "Air Compressor - Remove and Install".

[Previous Screen](#)

◀ Product: INDUSTRIAL ENGINE
 Model: 3054C INDUSTRIAL ENGINE 334
 Configuration: 3054C Industrial Engine 33400001-UP

Disassembly and Assembly 3054C Industrial Engine

Media Number -REN2433-03

Publication Date -01/11/2012

Date Updated -28/04/2017

i05570925

Fuel Injection Pump - Install - Delphi DP210

SMCS - 1251-012

Installation Procedure

Table 1

Required Tools			
Tool	Part Number	Part Name	Qty
A	230-6284	Timing Pin (Camshaft)	1
B	230-6283	Timing Pin (Crankshaft)	1
C	9U-6198	Crankshaft Turning Tool	1
D	1U-6396	O-Ring Assembly Compound	1

NOTICE

Keep all parts clean from contaminants.

Contaminants may cause rapid wear and shortened component life.

1. Use Tooling (C) to ensure that the No. 1 cylinder is at the top center compression stroke. Refer to Testing and Adjusting, "Fuel Injection Timing - Check".

Note: Install Tooling (A) through the camshaft gear. Install Tooling (B) through the crankshaft web.

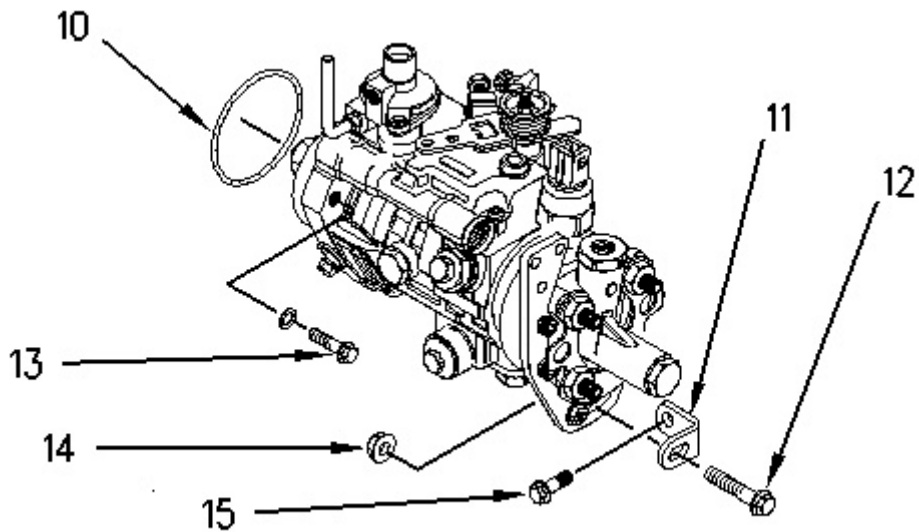

Illustration 1

g00956267

2. Use Tooling (D) in order to lubricate O-ring seal (10). Install a new O-ring seal (10) onto the fuel injection pump.
3. Install new washers to bolts (13).
4. Align the holes in the fuel injection pump with the holes in the front housing. Install the fuel injection pump to the housing.

Note: The fuel injection pump should be supported by hand until the bolts are installed.

5. Install bolts (13). Tighten bolts (13) to a torque of 22 N·m (16 lb ft).
6. Position support bracket (11) onto the cylinder block. Install bolt (15) finger tight.
7. Install bolt (12) and nut (14) finger tight.
8. Tighten bolt (12) and nut (14) to a torque of 22 N·m (16 lb ft). Tighten bolt (15) to a torque of 44 N·m (32 lb ft).

Note: Ensure that the fuel injection pump is not stressed as the bolts for the bracket are tightened.

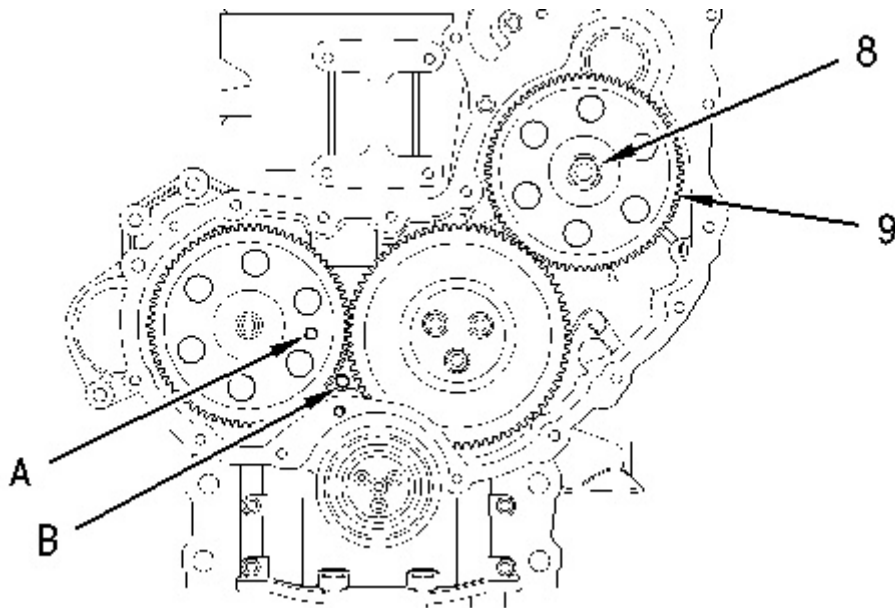

Illustration 2

g00956200

Note: Ensure that the mating surfaces of the fuel injection pump gear and the shaft of the fuel injection pump are clean. Lubricate the threads of the shaft for the fuel injection pump. The nut must turn freely until contact is made with the fuel injection pump gear.

9. Position fuel injection pump gear (9) on the shaft of the fuel injection pump. Install the washer and nut (8). Rotate the fuel injection pump gear in a counterclockwise direction in order to remove the backlash. Tighten nut (8) to a torque of 24 N·m (17 lb ft).

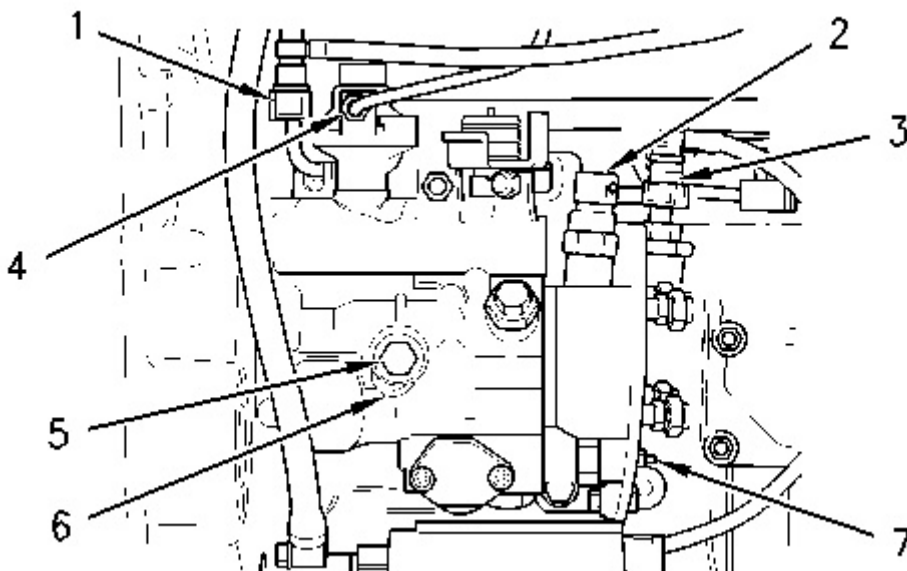

Illustration 3

g00956204

10. Connect the harness assembly to timing advance solenoid (7).
11. Connect harness assembly (2). Connect fuel line (3).
12. Connect fuel return line (1). Connect tube assembly (4) to the fuel injection pump.

- Loosen bolt (5). Move spacer (6) in order to prevent bolt (5) from tightening against the shaft of the fuel injection pump. Tighten bolt (5) to a torque of 12 N·m (106 lb in).

Note: Spacer (6) must be correctly positioned and bolt (5) must be tightened in order to prevent the bolt from contacting the shaft of the fuel injection pump.

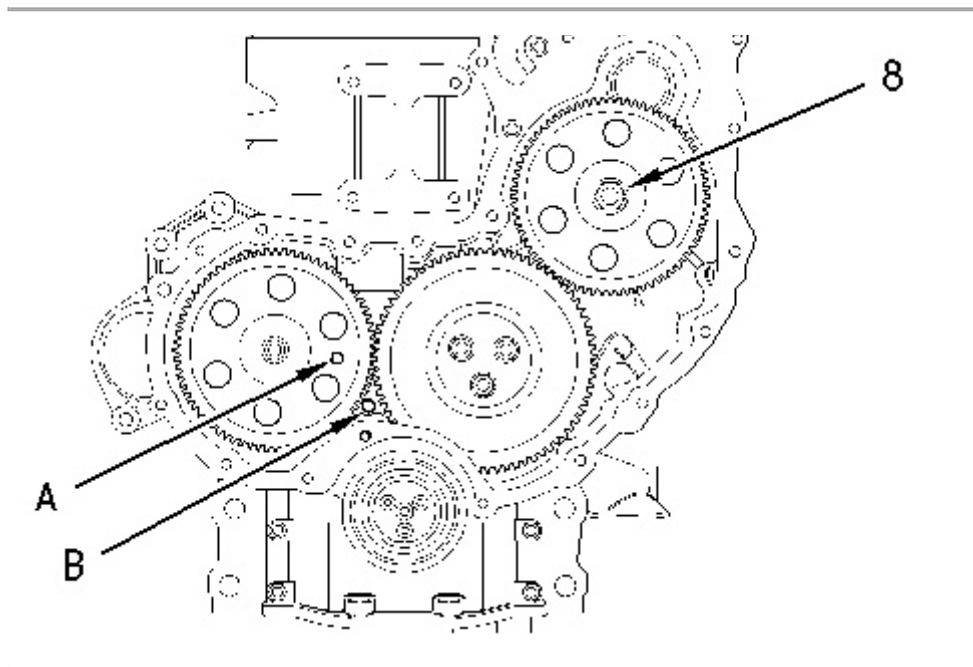

Illustration 4

g00992965

- Tighten nut (8) to a torque of 88 N·m (65 lb ft).
- Remove Tooling (A) and Tooling (B).

End By:

- Install the front cover. Refer to Disassembly and Assembly, "Front Cover - Remove and Install".
- Install the crankshaft pulley. Refer to Disassembly and Assembly, "Crankshaft Pulley - Remove and Install".
- Install the fuel injection lines. Refer to Disassembly and Assembly, "Fuel Injection Lines - Remove and Install".
- Install the air compressor, if equipped. Refer to Disassembly and Assembly, "Air Compressor - Remove and Install".

[Previous Screen](#)

Product: INDUSTRIAL ENGINE
Model: 3054C INDUSTRIAL ENGINE 334
Configuration: 3054C Industrial Engine 33400001-UP

Disassembly and Assembly 3054C Industrial Engine

Media Number -REN2433-03

Publication Date -01/11/2012

Date Updated -28/04/2017

i02291815

Turbocharger - Remove

SMCS - 1052-011

Removal Procedure

NOTICE

Keep all parts clean from contaminants.

Contaminants may cause rapid wear and shortened component life.

NOTICE

Care must be taken to ensure that fluids are contained during performance of inspection, maintenance, testing, adjusting, and repair of the product. Be prepared to collect the fluid with suitable containers before opening any compartment or disassembling any component containing fluids.

Refer to Special Publication, NENG2500, "Dealer Service Tool Catalog" for tools and supplies suitable to collect and contain fluids on Cat products.

Dispose of all fluids according to local regulations and mandates.

1. Thoroughly clean the outer surfaces of the turbocharger (1).

2. Loosen the hose clamps and remove the air inlet hose at the turbocharger compressor housing.

Note: The exhaust elbow is an option.

3. Remove the exhaust pipe from the turbocharger outlet or remove the exhaust pipe from the exhaust elbow, if equipped. Refer to the OEM provided information for the correct procedure in order to remove the exhaust pipe.

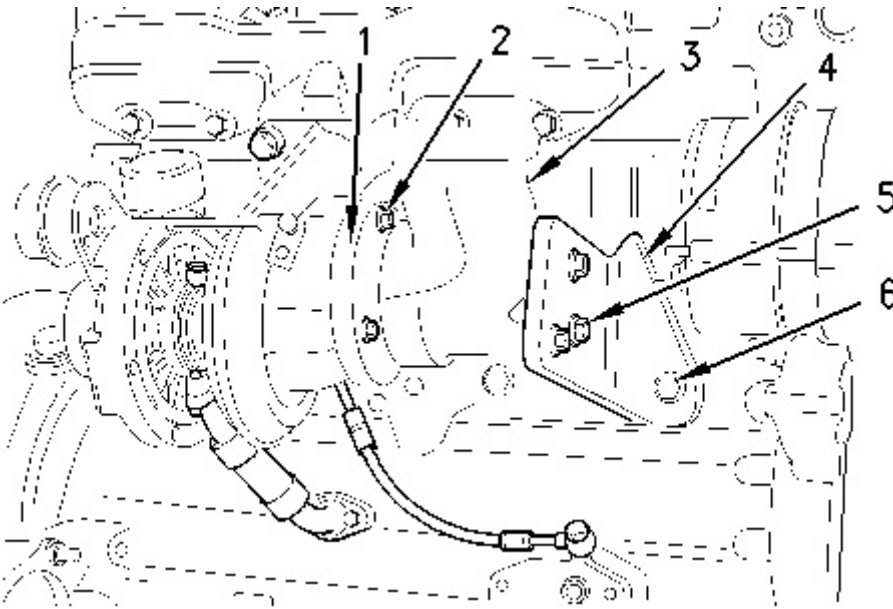

Illustration 1

g00975635

4. Remove the setscrews (5) from the exhaust elbow (3), if equipped.
 5. Remove the setscrews (6) and remove the bracket (4) from the cylinder block.
 6. If equipped, remove the exhaust elbow (3) from the exhaust adapter (1).
 7. Remove the nuts (2) and remove the exhaust adapter (1) from the turbocharger.
 8. Place a suitable container below the turbocharger (1) in order to collect any spillage of oil.
-

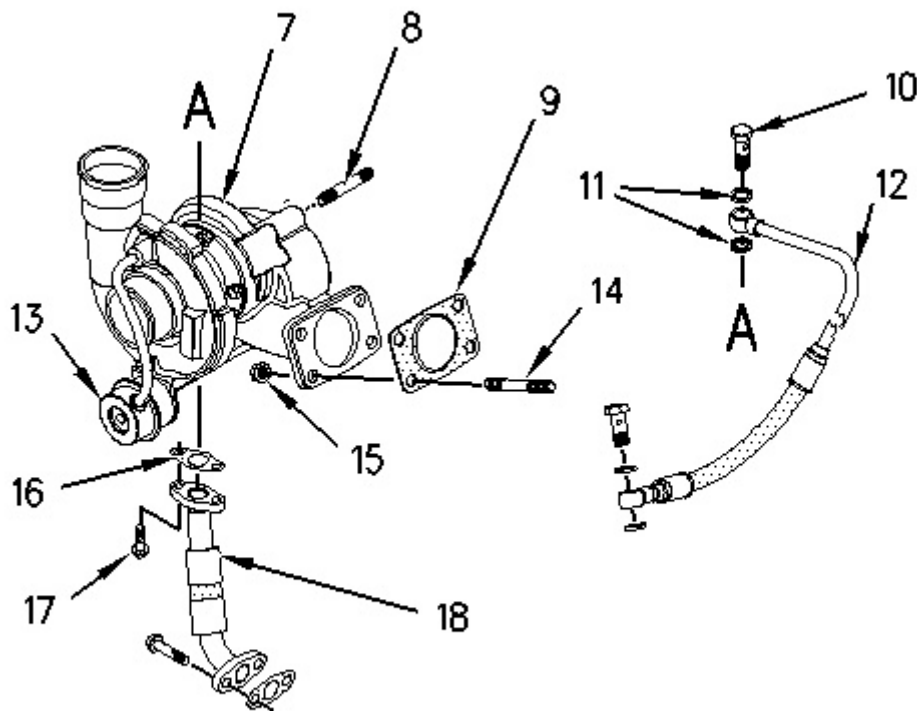

Illustration 2

g00975609

9. Remove the banjo bolt (10). Remove the oil supply tube assembly (12) and the washers (11) from the turbocharger. Discard the washers (11). If necessary, remove the oil supply tube assembly (12) from the cylinder block and discard the washers.
 10. Remove the setscrews (17). Remove the oil drain tube assembly (18) from the turbocharger. Remove the gasket (16) and discard the gasket. If necessary, remove the oil drain tube assembly from the cylinder block and discard the gasket.
 11. If necessary, remove the studs (8) from the turbocharger housing.
 12. Remove the nuts (15). Remove the turbocharger (7). Remove the gasket (9). Discard the gasket (9). If necessary, remove the studs (14) from the exhaust manifold.
- Note:** Do not use the actuator rod of wastegate (13) to lift the turbocharger.
13. Plug the oil supply and the oil drain ports of the turbocharger. Install covers on the manifold ports.

[Previous Screen](#)

◀ Product: INDUSTRIAL ENGINE
 Model: 3054C INDUSTRIAL ENGINE 334
 Configuration: 3054C Industrial Engine 33400001-UP

Disassembly and Assembly 3054C Industrial Engine

Media Number -REN2433-03

Publication Date -01/11/2012

Date Updated -28/04/2017

i02291816

Turbocharger - Install

SMCS - 1052-012

Installation Procedure

Table 1

Required Tools			
Tool	Part Number	Part Description	Qty
A	5P-3931	Anti-Seize Compound	-

NOTICE

Keep all parts clean from contaminants.

Contaminants may cause rapid wear and shortened component life.

1. Remove all of the plastic plugs from all of the ports of the turbocharger. Clean the mating surfaces of the exhaust manifold and the turbocharger. Clean the mating surfaces of turbocharger and the oil supply tube assembly and the oil drain tube assembly.
 2. Ensure that the turbocharger inlet and outlet ports are clean and free from restrictions. The turbocharger shaft must rotate freely.
-

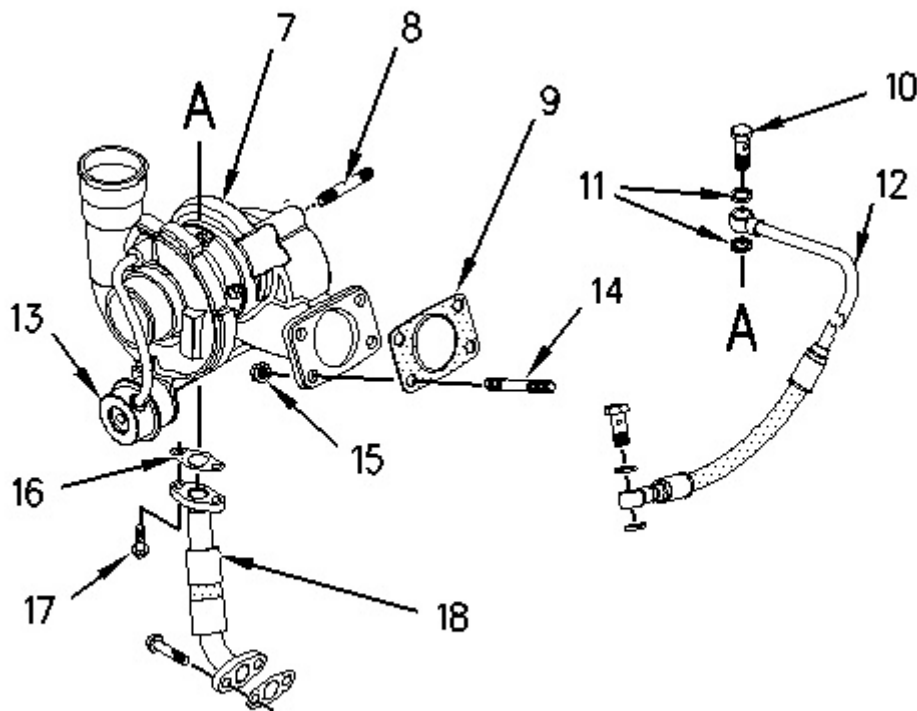

Illustration 1

g00975609

3. If necessary, install the studs (14) in the exhaust manifold. Install gasket (9) over the studs.

Note: Do not use any sealant on the gasket.

4. Position the turbocharger (7) on the exhaust manifold.
5. Apply Tooling (A) to the threads of studs (14). Install the nuts (15). Tighten the nuts to a torque of 47 N·m (35 lb ft).
6. Lubricate the bearing housing with clean engine oil.
7. Inspect the oil hose assemblies (12 and 18). If necessary, replace the hose assemblies.

Note: The top flange of the oil drain tube assembly (18) is secured to the turbocharger with 6 mm setscrews (17). The bottom flange of the oil drain tube assembly (18) is secured to the cylinder block with 8 mm setscrews.

8. Position a new gasket (16) and the oil drain tube assembly (18) on the bottom of the turbocharger. Install the setscrews (17). Tighten the setscrews to a torque of 9 N·m (80 lb in).
9. If necessary, install a new gasket and the oil drain tube assembly (18) to the cylinder block. Tighten the setscrews to a torque of 22 N·m (16 lb ft).
10. Position new washers (11) and the oil supply tube assembly (12) on the turbocharger. Install the banjo bolt (10). Tighten the banjo bolt to a torque of 22 N·m (16 lb ft).

Note: Ensure that the oil supply tube assembly (12) does not come into contact with any other component when the assembly is installed onto the engine.

11. If necessary, install new washers and the oil supply tube assembly (12) to the cylinder block. Tighten the banjo bolt to a torque of 22 N·m (16 lb ft).
12. If necessary, install the studs (8) in the turbocharger housing.

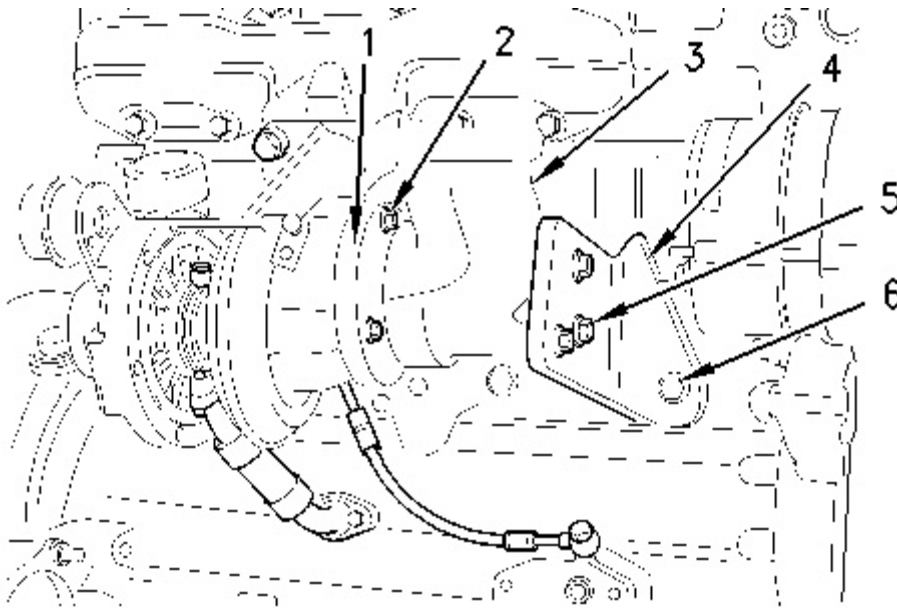

Illustration 2

g00975635

13. Position the exhaust adapter (1) on the studs (8). Install the nuts (2). Do not tighten the nuts at this time.

Note: The exhaust elbow is an option for this engine.

14. If equipped, install the exhaust elbow (3) onto the exhaust adapter (1). Position the bracket (4) on the cylinder block and install the setscrews (6).
15. Install the setscrews (5) in order to secure the exhaust elbow (3) to the bracket (4).
16. Tighten the three nuts (2) finger tight. Tighten the nuts in the same sequence to a torque of 25 N·m (18 lb ft).
17. Ensure that there is no restriction in the inlet hose. Position the air inlet hose on the turbocharger compressor housing. Install the hose clamps. Tighten the clamps to a torque of 5 N·m (44 lb in).

Note: The air inlet hose has a reflective heat shield that partially covers the hose. The reflective heat shield must be installed toward the engine. The reflective heat shield must be kept clean and free from dust, oil or paint.

Note: Use a solution of water and 5 % soap to install a new air inlet hose. Do not use oil or grease.

18. Position the exhaust pipe on the exhaust elbow or onto the exhaust adapter (1). Refer to the OEM information for the correct procedure in order to install the exhaust pipe.

[Previous Screen](#)

Product: INDUSTRIAL ENGINE
Model: 3054C INDUSTRIAL ENGINE 334
Configuration: 3054C Industrial Engine 33400001-UP

Disassembly and Assembly 3054C Industrial Engine

Media Number -REN2433-03

Publication Date -01/11/2012

Date Updated -28/04/2017

i02291817

Exhaust Manifold - Remove and Install

SMCS - 1059-010

Removal Procedure

Start By:

- a. Remove the turbocharger. Refer to Disassembly and Assembly, "Turbocharger - Remove".

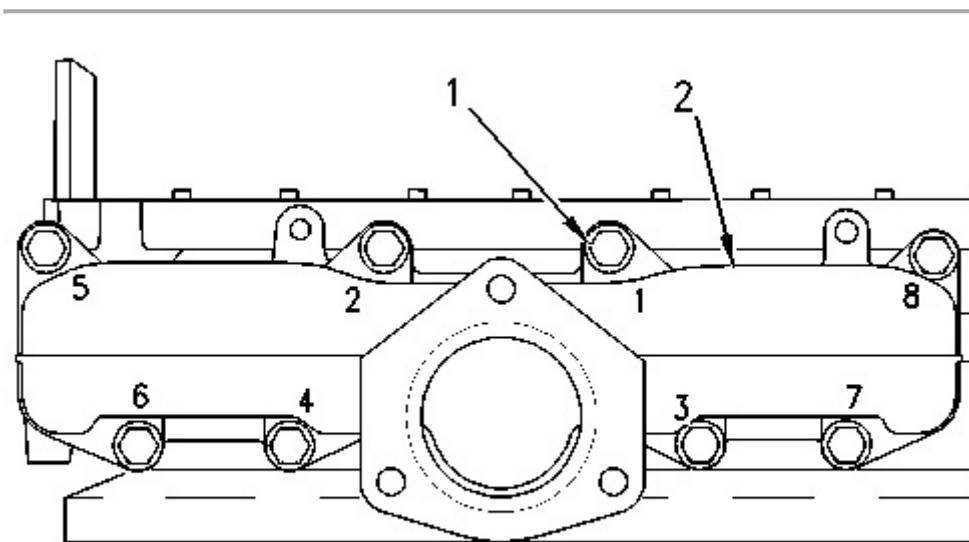

Illustration 1

g00951398

1. Remove the setscrews (1) in reverse numerical order. Refer to Illustration 1 . This will help prevent distortion of the exhaust manifold.
2. Remove the exhaust manifold from the cylinder head and the exhaust manifold gasket. Discard the exhaust manifold gasket.

Installation Procedure

Table 1

Required Tools			
Tool	Part Number	Part Description	Qty
A	-	Guide Bolt (M10 X 1.5 by 100 mm)	2

Note: Improper installation of the exhaust manifold can result in a cracked exhaust manifold. The setscrews that secure the exhaust manifold must be tightened in the correct sequence and to the correct torque.

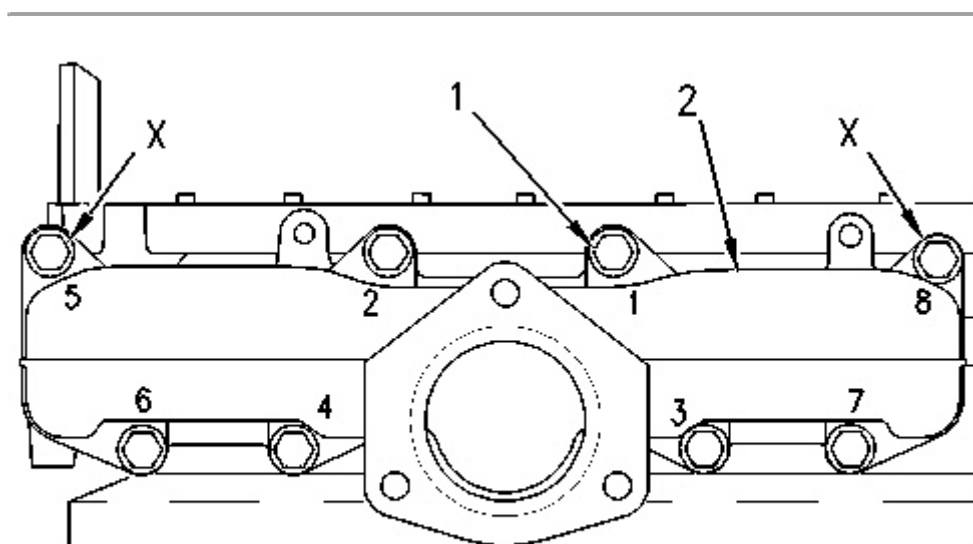

Illustration 2

g00951297

1. Install Tooling (A) in the cylinder head in Hole (X).

Note: Do not use any sealant on the exhaust manifold gaskets.

2. Position a new exhaust manifold gasket on the Tooling (A) in the cylinder head. Position the exhaust manifold on the Tooling (A). Install the setscrews (1) finger tight in order to secure the exhaust manifold to the cylinder head.
3. Remove the Tooling (A). Install the remaining setscrews (1) and tighten the setscrews evenly to a torque of 33 N·m (24 lb ft). Tighten the setscrews in the sequence that is shown in Illustration 2.

End By:

- a. Install the turbocharger. Refer to Disassembly and Assembly, "Turbocharger - Install".

[Previous Screen](#)

Product: INDUSTRIAL ENGINE
 Model: 3054C INDUSTRIAL ENGINE 334
 Configuration: 3054C Industrial Engine 33400001-UP

Disassembly and Assembly 3054C Industrial Engine

Media Number -REN2433-03

Publication Date -01/11/2012

Date Updated -28/04/2017

i02291819

Inlet and Exhaust Valve Springs - Remove and Install

SMCS - 1108-010

Removal Procedure

Table 1

Required Tools			
Tool	Part Number	Part Description	Qty
A	9U-6195	Valve Spring Compressor	1
B	9U-6198	Crankshaft Turning Tool	1

Start By:

- a. Remove the rocker shaft assembly. Refer to Disassembly and Assembly, "Rocker Shaft and Pushrod - Remove".

NOTICE

Keep all parts clean from contaminants.

Contaminants may cause rapid wear and shortened component life.

Note: The following procedure should be adopted in order to remove the valve springs when the cylinder head is still installed onto the cylinder block. Refer to Disassembly and Assembly Manual, "Inlet and Exhaust Valves - Remove and Install" for the correct procedure that should be used to remove the valve springs from a cylinder head that has been removed from the cylinder block.



Suggest:

If the above button click is invalid.

Please download this document

first, and then click the above link

to download the complete manual.

Thank you so much for reading

Note: Before you begin the removal of the valve springs, refer to Specifications, "Cylinder Head Valves" for appropriate information on the valve springs.

1. Ensure that the piston is at the top center position before the valve keepers are removed from the valve. Failure to ensure that the piston is at top dead center may allow the valve to drop into the cylinder block. Use the following procedure in order to find the top center position for the piston.

NOTICE

Do not turn the crankshaft while the valve springs are removed.

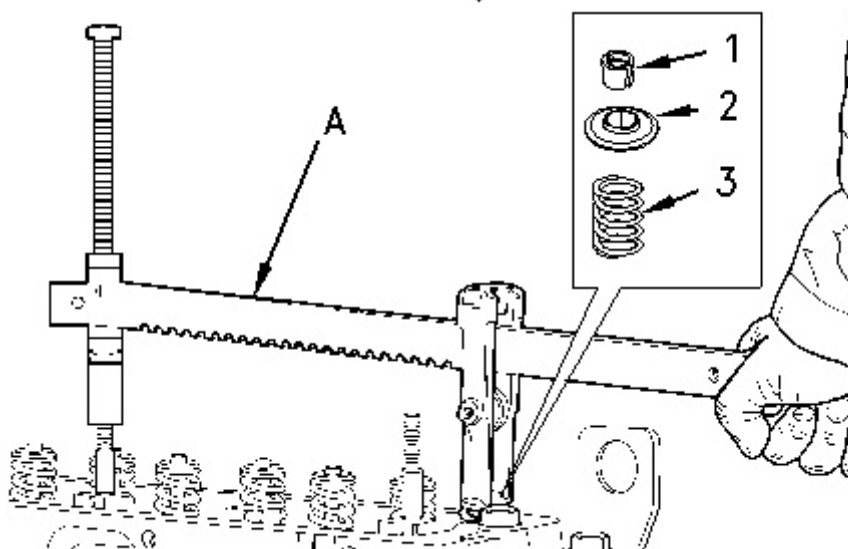

Illustration 1

g00937233



WARNING

Personal injury can result from being struck by parts propelled by a released spring force.

Make sure to wear all necessary protective equipment.

Follow the recommended procedure and use all recommended tooling to release the spring force.

-
- a. Install the Tooling (A).
-

<https://www.ebooklibonline.com>

Hello dear friend!

Thank you very much for reading.

Enter the link into your browser.

The full manual is available for immediate download.

<https://www.ebooklibonline.com>