



# Service Repair Manual

## **Models**

# 962G WHEEL LOADER

---

[Previous Screen](#)

Product: WHEEL LOADER

Model: 962G WHEEL LOADER 6HW

Configuration: 962G WHEEL LOADER 6HW00001-00400 (MACHINE) POWERED BY 3126 ENGINE

## Disassembly and Assembly 3114, 3116 and 3126 MUI Engine Governors

Media Number -SEN6454-05

Publication Date -01/02/2002

Date Updated -01/03/2002

i01514752

## Governor (Type I) - Assemble

SMCS - 1264-016

### Assembly Procedure

Table 1

Required Tools			
Tool	Part Number	Part Description	Qty
A	1U-7307	Governor Repair Fixture <sup>(1)</sup>	1
B	1U-7635	Clevis Driver <sup>(1)</sup>	1
C	1U-7606	Servo Block <sup>(1)</sup>	1
D	1U-7277	Pin Punch	1
E	1P-1857	Retaining Ring Pliers	1
F	1P-1855	Retaining Ring Pliers	1
G	1U-7310	Torque Adjusting Tool <sup>(1)</sup>	1
H	1U-7311	Wrench <sup>(1)</sup>	1
I	1U-7309	Shim Adjustment Tool <sup>(1)</sup>	1
J	1U-7313	Gauge Block <sup>(1)</sup>	1
K	1U-7312	Calibration Plate <sup>(1)</sup>	1
L	1U-7314	Weight <sup>(1)</sup>	1
M	1U-7308	Shim Adjustment Tool <sup>(1)</sup>	1

<sup>(1)</sup> Part of the former **1U-9088** Tool Group

## NOTICE

**Keep all parts clean from contaminants.**

**Contaminants may cause rapid wear and shortened component life.**

---

**Note:** Inspect all parts of the governor upon assembly. For information on the reusability of components in the governor, refer to the Guideline For Reusable Parts And Salvage Operations, SEBF8434, "3100 Governor Inspection and General Information for Mechanical Governor Groups Used in 3114, 3116, and 3126 Engines Equipped with Mechanical Unit Injectors (MUI)". For information on cleaning the components in the governor, refer to the The Cleaning Guide, SEBF8354, "Equipment And Chemical Recommendations Reference Manual".

**Note:** Refer to Chart A "Parts to be Replaced During Rebuild" in Guideline For Reusable Parts And Salvage Operations, SEBF8434 for a list of components that need to be replaced during a governor rebuild. It is not necessary to replace the components in Chart A "Parts to be Replaced During Rebuild" if the governor is in the shop for a bench test or for minor repair.

**Note:** Early Type I Governors had limited production until 1991. The early Type I Governors may be inspected and perhaps reconditioned. However, some of the internal components are no longer serviced or the internal components may only be serviced by larger assemblies. When you recondition a Type I Governor, it may be necessary to replace the governor. If extensive repair work is necessary, a Type I Governor can be replaced with a Type IV Governor.

**Note:** Put clean engine oil on all parts before assembly. Ensure that all of the oil passages in the governor are free of obstructions.



Illustration 1

g00523199

**Note:** Inspect the cam on the fuel transfer pump. If the cam has excessive wear, it will be necessary to replace the entire drive assembly.

1. Mount the drive gear end of the governor on Tool (A). Install drive gear (90) .

**<https://www.ebooklibonline.com>**

Hello dear friend!

Thank you very much for reading.

Enter the link into your browser.

The full manual is available for immediate download.

**<https://www.ebooklibonline.com>**

## **WARNING**

**Personal injury can result from being struck by parts propelled by a released spring force.**

**Make sure to wear all necessary protective equipment.**

**Follow the recommended procedure and use all recommended tooling to release the spring force.**

---

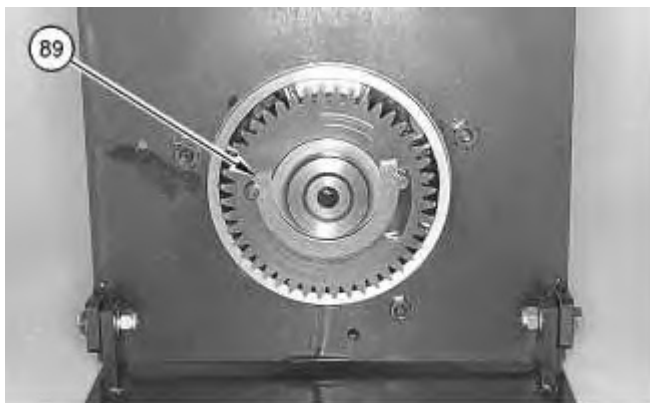

Illustration 2

g00523198

2. Install C spring (89) carefully in order to avoid personal injury.



Illustration 3

g00523197

3. Install cover (88). Install the sleeve assembly and bolt (87) that holds cover (88) in position.
-

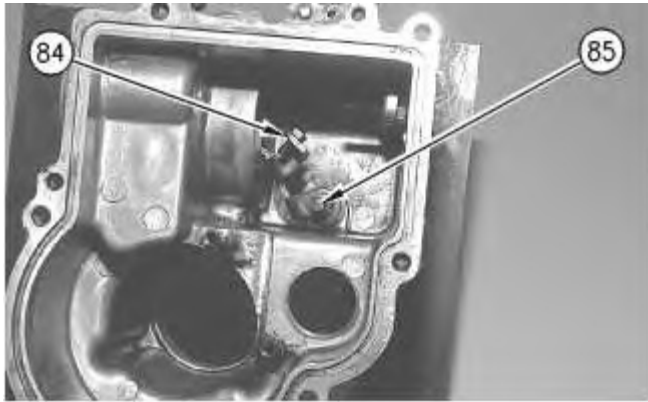

Illustration 4

g00523195

4. Install fuel ratio control lever assembly (84) onto shaft (85) .



Illustration 5

g00523196

5. Install O-ring seal (86) onto fuel ratio control valve (81) .

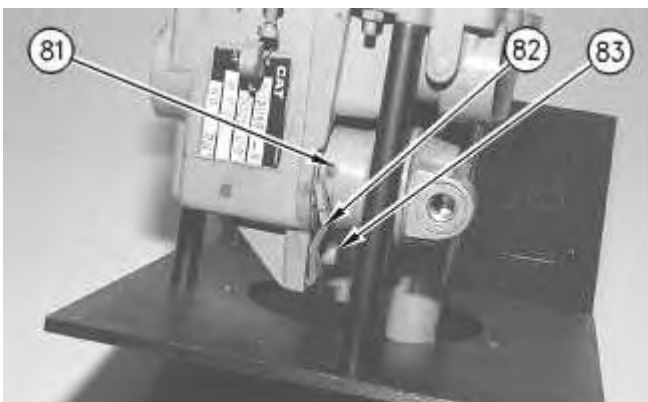

Illustration 6

g00523194

6. Put fuel ratio control valve (81) in position on the governor. Install bracket (82) and bolt (83) in order to hold fuel ratio control valve (81) in position.

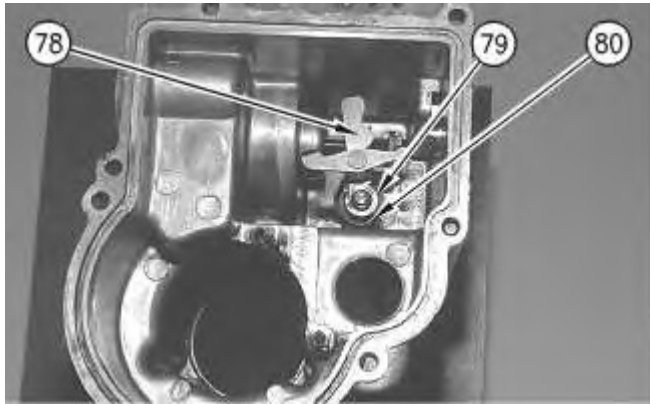

Illustration 7

g00523193

7. Install limit lever assembly (78), washer (79), and spring (80). Ensure that the straight end of spring (80) is resting on the aluminum casting.

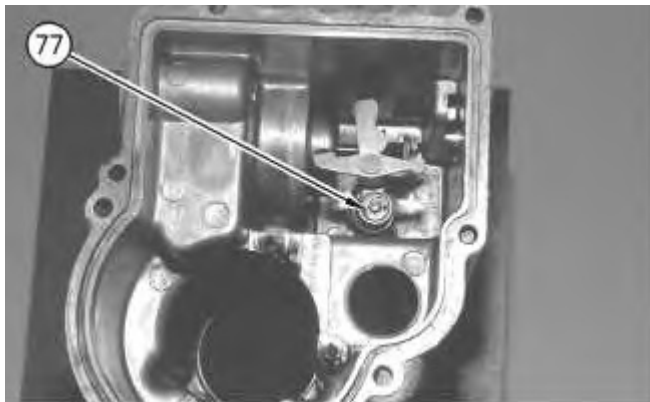
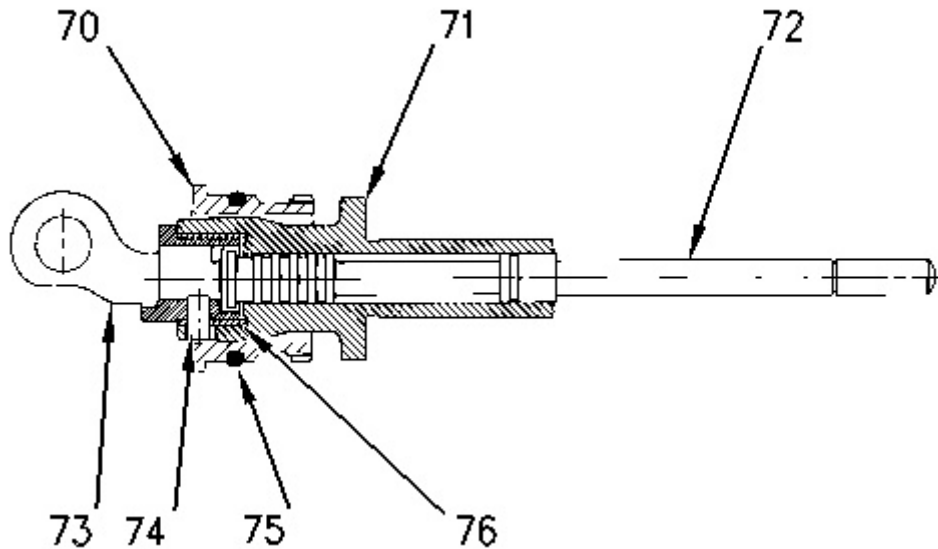

Illustration 8

g00523192

8. Install retaining clip (77) .
  9. Use the following procedure to assemble the later style of governor output servo assembly.
    - a. Thoroughly clean all of the parts of the governor output servo assembly.
-



---

Illustration 9

g00523041

Governor Output Servo (Later Style)

- (70) Sleeve
- (71) Servo piston
- (72) Servo Valve
- (73) Clevis
- (74) Spring pin
- (75) O-ring seal
- (76) Tolerance Ring

- b. Install servo valve (72) into servo piston (71) .
  - c. Install O-ring seal (75) onto sleeve (70) and slide the sleeve onto servo piston (71) .
  - d. Install a new **109-4587** Tolerance Ring (76) into the large bore in the end of servo piston (71). Position the tolerance ring so that the gap in the tolerance ring lines up with the hole through the side of the piston that is for spring pin (74). Push the tolerance ring into the bore until the tolerance ring bottoms out.
-

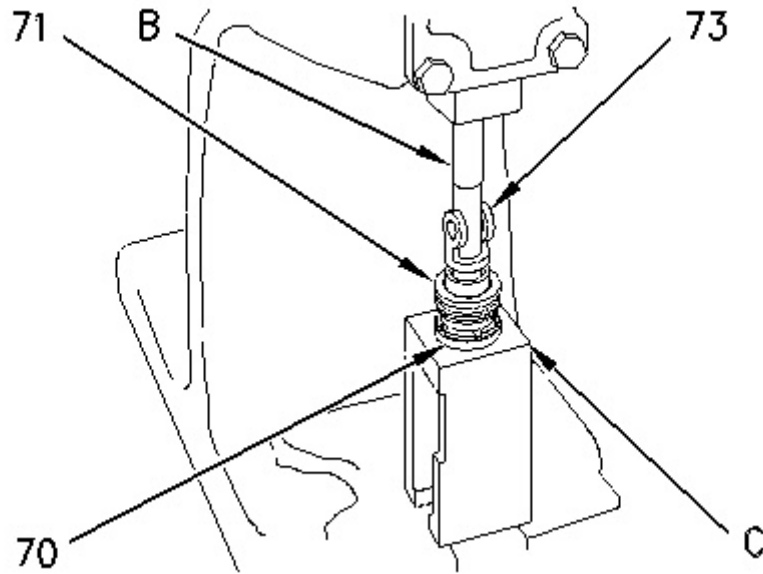

---

Illustration 10

g00524388

(B) 1U-7635 Clevis Driver

(C) 1U-7606 Servo Block

(70) Sleeve

(71) Servo piston

(73) Clevis

- e. Place Tool (C) in a vertical position. The small round hole should face upward. Put the servo assembly in position on Tool (C). Install servo valve (72) in an upward position.
  - f. Put clevis (73) in position on the servo valve, as shown. Use Tool (B) to press clevis (73) into servo piston (71) from the end with the tolerance ring.
  - g. Position clevis (73) so that the hole for spring pin (74) is in alignment with the gap in the tolerance ring and the hole in servo piston (71). Press clevis (73) until the clevis bottoms out against servo piston (71).
-

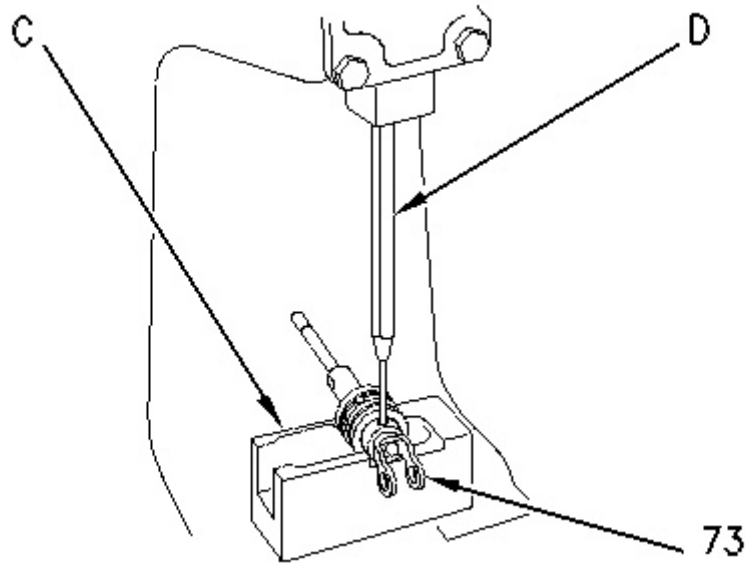

---

Illustration 11

g00524660

(C) 1U-7606 Servo Block

(D) 1U-7277 Pin Punch

(73) Clevis

- h. Position Tool (C) on the side so the notch is facing upward. Position the governor output servo so the sleeve is in the recess of Tool (C). Insert clevis (73) into the servo piston in the recess that is marked "PIN". Rotate the governor output servo so that the hole for spring pin (74) is aligned with clevis (73). Use Tool (D) to press a new **6D-9953** Spring Pin (74) into the governor output servo until the end of the spring pin is flush with the outside diameter of the servo piston.
10. Use the following procedure to assemble the earlier style of governor output servo assembly.
- a. Thoroughly clean all of the parts of the governor output servo assembly.
-

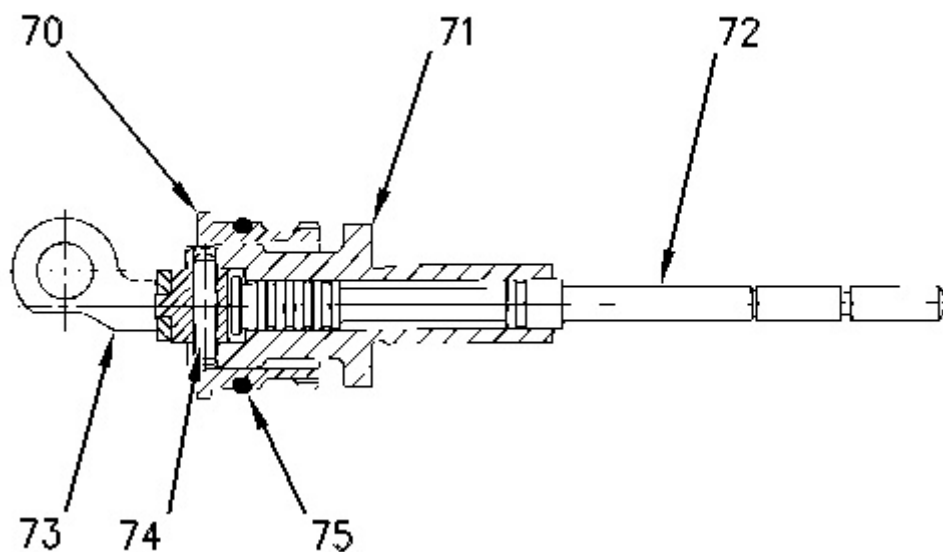

---

Illustration 12

g00523034

Governor Output Servo (Earlier Style)

(70) Sleeve

(71) Servo piston

(72) Servo Valve

(73) Clevis

(74) Spring pin

(75) O-ring seal

b. Install servo valve (72) into servo piston (71) .

c. Install O-ring seal (75) onto sleeve (70) and slide the sleeve onto servo piston (71) .

---

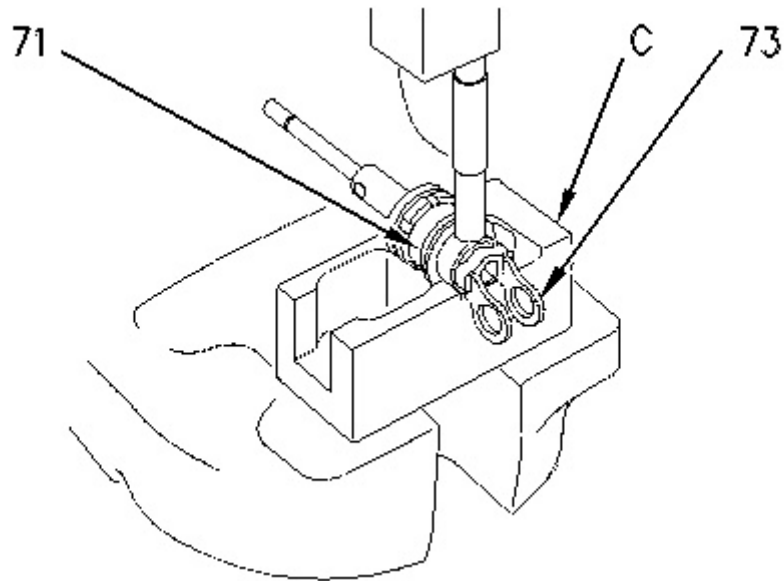

Illustration 13

g00524383

(C) 1U-7606 Servo Block

(71) Servo piston

(73) Clevis

- d. Position Tool (C) on the side so the notch is facing upward. Position the governor output servo so the sleeve is in the recess of Tool (C). Position the clevis end of the servo piston in the recess. The recess will be marked "PIN" on the side.
- e. Insert clevis (73) into the piston bore.
- f. Align the holes in clevis (73) and servo piston (71). Press a new **4H-1641** Spring Pin (74) until the end of the spring pin is flush with the outside diameter of servo piston (71).

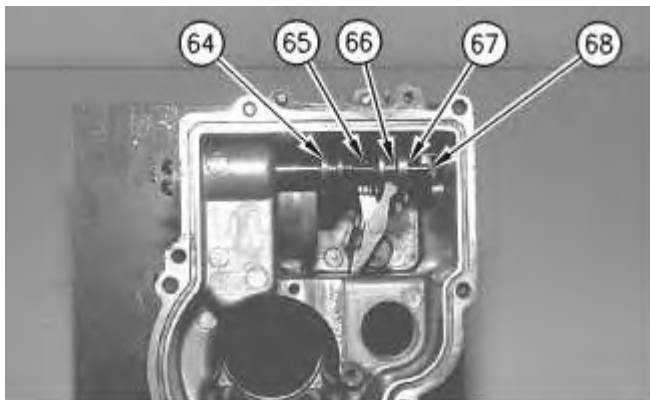

Illustration 14

g00524666

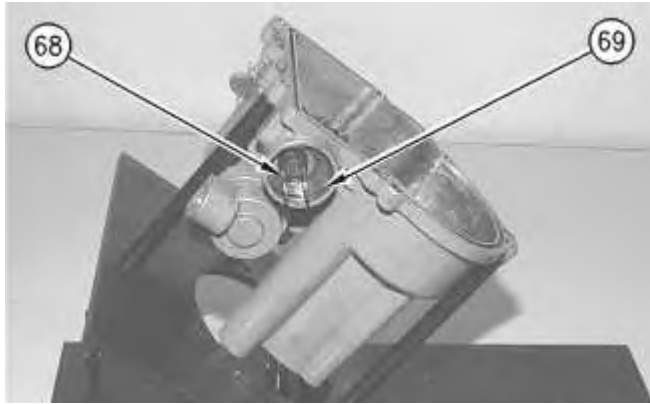

Illustration 15

g00523033

**Note:** Lubricate the bore of the governor rear housing lightly with clean engine oil before the governor output servo is installed.

11. To install governor output servo (68) into the governor rear housing, push the small end of the governor output servo through the opening in the governor rear housing. Install sleeve (64), spring (65) and sleeve (66) onto the governor output servo.
12. Press on the clevis of governor output servo (68) until the governor output servo is seated in the bore of the governor rear housing. Install retaining ring (69) with Tool (E) .
13. Push limit sleeve (66) and control sleeve (64) toward the side of the governor housing that holds the clevis in order to compress spring (65). Install retaining ring (67) when spring (65) is compressed.

**Note:** Some servo assemblies may have a second retaining ring on the servo valve. Install the second retaining ring between the control sleeve and the limit sleeve.

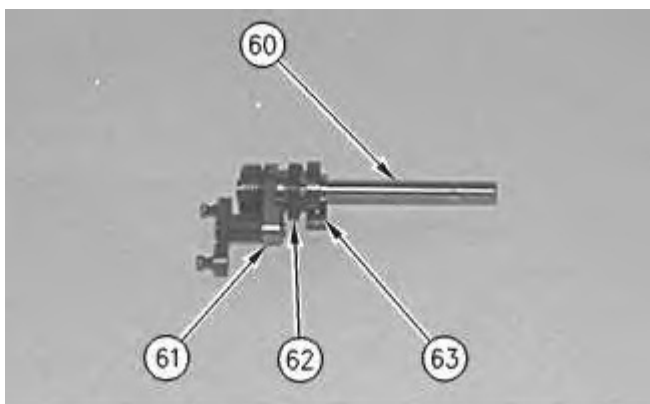

Illustration 16

g00523007

14. Install the spring and fulcrum lever (61) on pivot shaft (60). Install torsion spring (62) and torque cam adjuster (63) onto pivot shaft (60) .

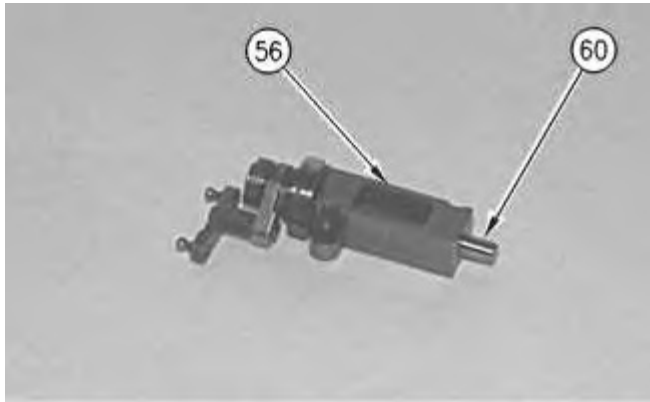

Illustration 17

g00523005

15. Install bearing block assembly (56) onto pivot shaft (60) .

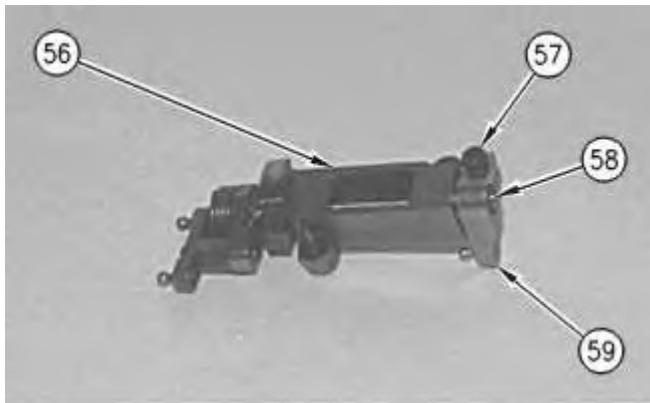
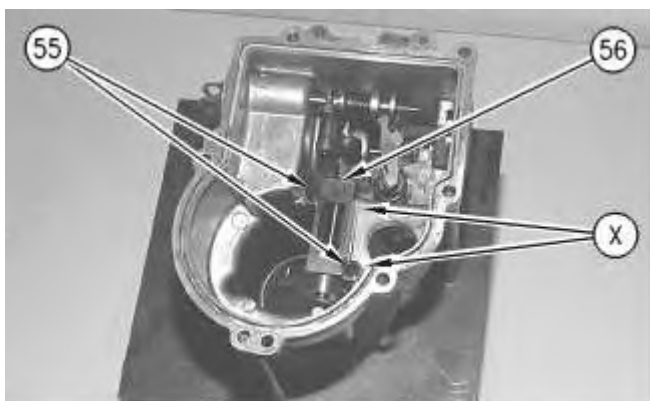

Illustration 18

g00523003

16. Install riser lever (59) onto bearing block assembly (56). Use Tool (B) to install retaining ring (58). Install bolt (57) but do not tighten the bolt at this time. Use a feeler gauge to obtain a  $0.15 \pm 0.05$  mm ( $0.006 \pm 0.002$  inch) clearance between bearing block (56) and riser lever (59). When the proper clearance is reached, tighten bolt (57) .



---

## NOTICE

**Bearing block position affects rack output. If the bearing block assembly is positioned too closely to the riser shaft side, high idle may not be reached. If the bearing block assembly is positioned too far from the riser shaft side, fuel shutoff may not be obtained.**

---

**Note:** Scribe marks (X) indicate the vertical position of the bearing block and the horizontal position of the bearing block. Scribe marks (X) were made during disassembly. The marks are located on the aluminum housing near the hole for the fuel shutoff solenoid. The bearing block assembly must be located as close as possible to the scribe marks.

17. Put bearing block (56) into position in the governor rear housing. Install two bolts and washers (55). Tighten the bolts to a torque of  $4 \pm 1$  N·m ( $35 \pm 9$  lb in).



Illustration 20

g00695589

18. Mount the governor rear housing on the **1U-7307** Governor Repair Fixture (Tool (A) ) with the three legs that are included. Prepare seal (54) for the governor rear housing. Do not install seal (54) until the gap for the torque cam is adjusted.
  19. Use the following procedure to adjust the gap for the Torque Cam on Type I governors.
-

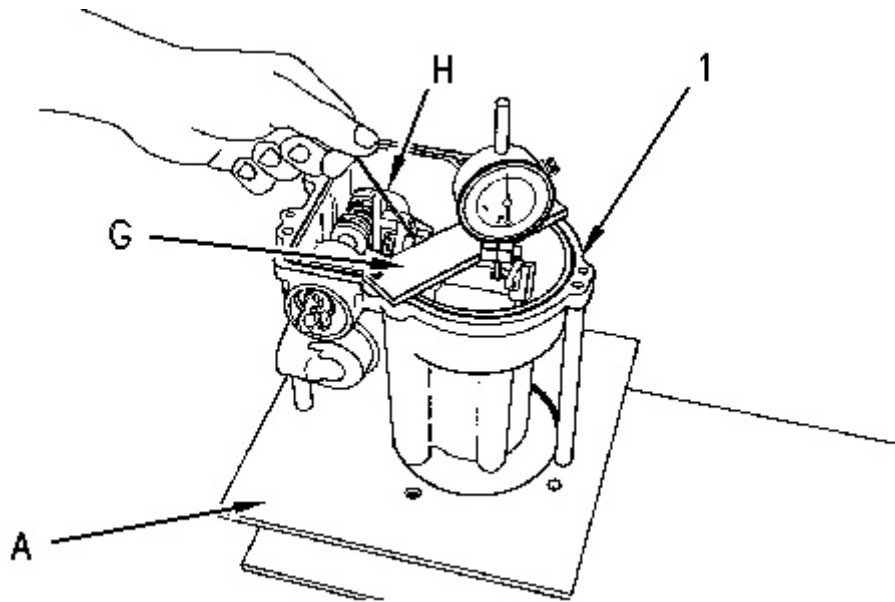

Illustration 21

g00524706

(1) Seal

(A) Governor Repair Fixture

(G) Torque Adjusting Tool and Dial Indicator

(H) Wrench

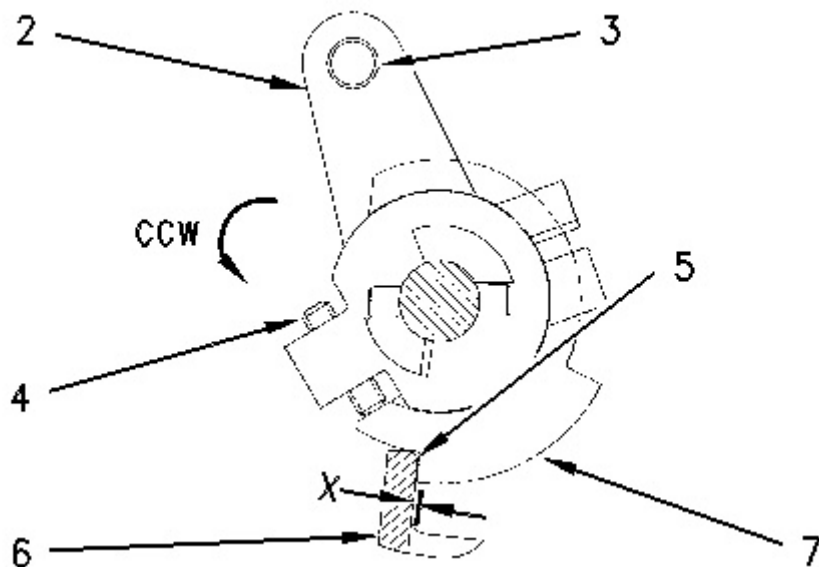

Illustration 22

g00524770

(2) Riser lever

(3) Riser lever swivel

(4) Torque cam setscrew

- (5) Shoulder for the torque cam lever
  - (6) Torque cam lever
  - (7) Torque cam
  - (X) Torque cam dimension
- 
- a. Install the three legs that are included with Tool (A), as shown. Install the governor rear housing on the legs.
  - b. Use the **1U-7310** Torque Adjusting Tool (Tool (G) ) to adjust the position of the torque cam.
  - c. Grasp riser lever (2) and rotate the riser lever counterclockwise. Rotate the riser lever until torque cam lever (6) snaps past shoulder (5) on torque cam (7). Move torque cam lever (6) over shoulder (5) on torque cam (7). Rotate riser lever (2) clockwise until torque cam lever (6) contacts shoulder (5) on torque cam (7) .
  - d. Use two of the bolts that are furnished in the former **1U-9088** Governor Repair Group to fasten Tool (G) to the governor housing. The post of Tool (G) should be facing downward in order to make contact with riser lever swivel (3). Attach a **5S-8086** Contact Point to the tip of the dial indicator. Install the dial indicator into Tool (G) until the dial indicator bottoms out. The tip of the dial indicator should rest on the edge of riser lever (2) .
  - e. Place the **1U-7311** Wrench (Tool (H) ) into torque cam setscrew (4). Use Tool (H) as a lever in order to rotate torque cam (7) counterclockwise until riser lever swivel (3) contacts the post on Tool (G). Continue rotating torque cam (7) counterclockwise in order to wind up the torsion spring. Hold Tool (H) in this position and zero the dial indicator. The large dial makes several sweeps during the procedure. It is important to zero all of the dials in order to be certain of the total indicator reading at the end of the procedure. Tighten the setscrew on Tool (G) in order to secure the dial indicator.
  - f. Use Tool (H) as a lever again and rotate the assembly counterclockwise until torque cam (7) and torque cam setscrew (4) break apart. Release the pressure on Tool (H) slowly until the setscrew comes in contact again with torque cam (7). Remove your hand from Tool (H). The reading on the dial indicator will show dimension (X) for the torque cam . Refer to the TMI in order to get the correct dimension (X) .
  - g. If necessary, adjust the setscrew and repeat Steps 19.e and 19.f until the correct dimension (X) is indicated on the dial indicator.
  - h. Install seal (1) on the governor rear housing.
20. Remove the governor rear housing from Tool (A). Install the governor front housing in Tool (A) .
-



Illustration 23

g00522952

21. Install lower O-ring seal (53) into the fuel transfer pump housing.

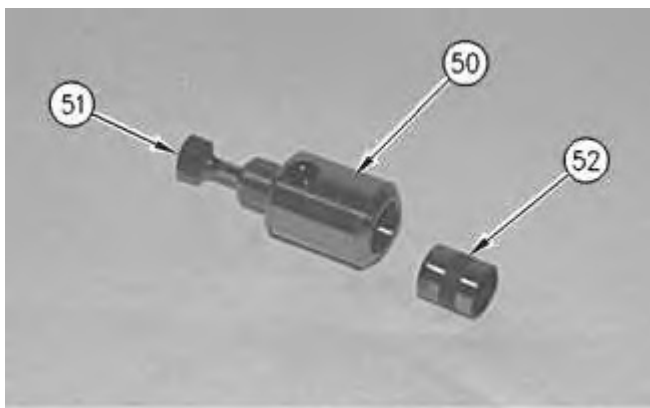

Illustration 24

g00522951

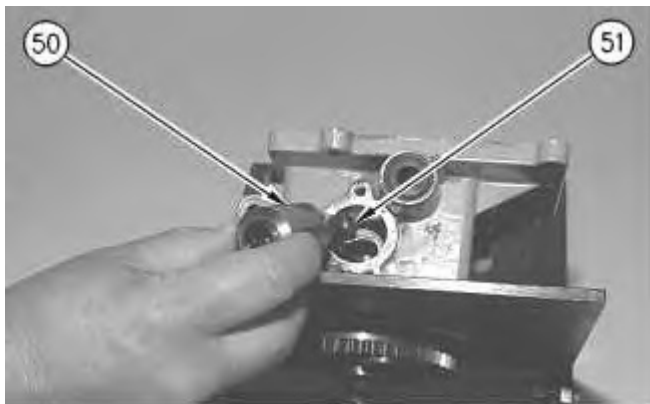

Illustration 25

g00522950

22. Install piston (52) into sleeve assembly (50) .

23. Install sleeve assembly (50) and tappet (51) into the governor front housing.



Illustration 26

g00522905

24. Install spring (48) and O-ring (49) .

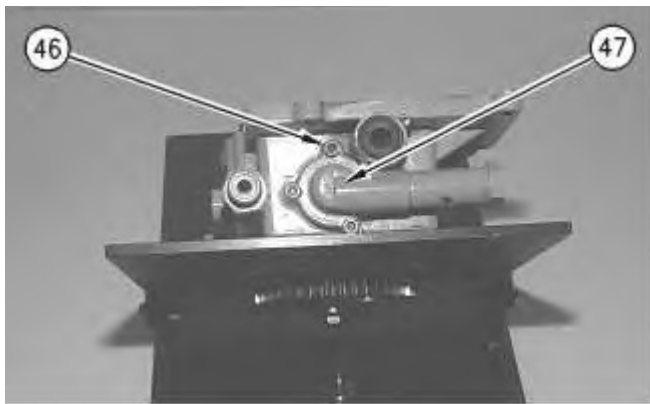

Illustration 27

g00522904

## **WARNING**

**Personal injury can result from being struck by parts propelled by a released spring force.**

**Make sure to wear all necessary protective equipment.**

**Follow the recommended procedure and use all recommended tooling to release the spring force.**

25. Hold cover assembly (47) in position on the governor front housing and install three bolts (46) .

**Note:** Make sure that cover assembly (47) is securely fastened to the governor housing. Fuel may leak around the O-ring seal if cover assembly (47) is not tight. Make sure that the fuel inlet fitting is tight in cover assembly (47) in order to ensure that no leaks occur.

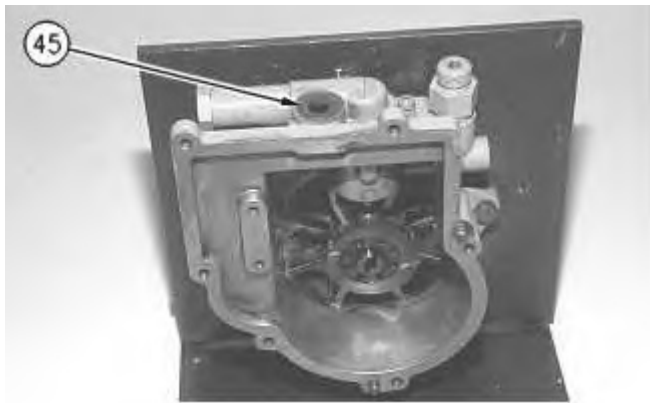

Illustration 28

g00522902

26. Install a new throttle shaft seal (45) if the seal was removed.



Illustration 29

g00522900

27. Install throttle shaft (37) into the governor front housing.
-

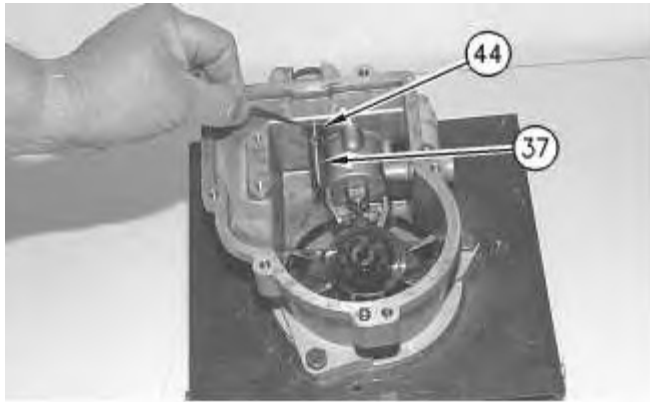

Illustration 30

g00522898

28. Install retaining clip (44) onto throttle shaft (37) .



Illustration 31

g00522826

29. Install control lever (40), setscrew (41), spring (42), and spacer (43) onto throttle shaft (37) .

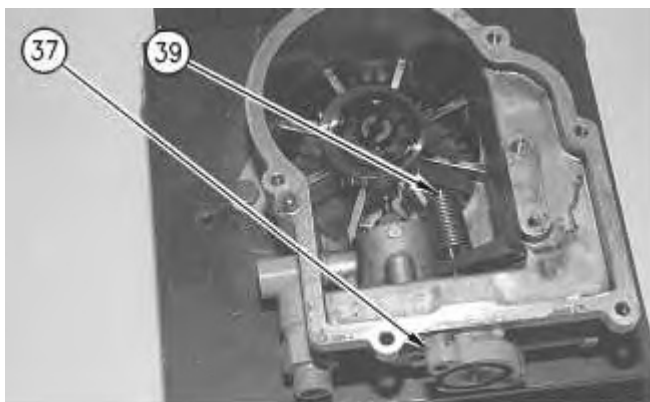

Illustration 32

g00522823

30. Install retaining clip (39) onto throttle shaft (37) .

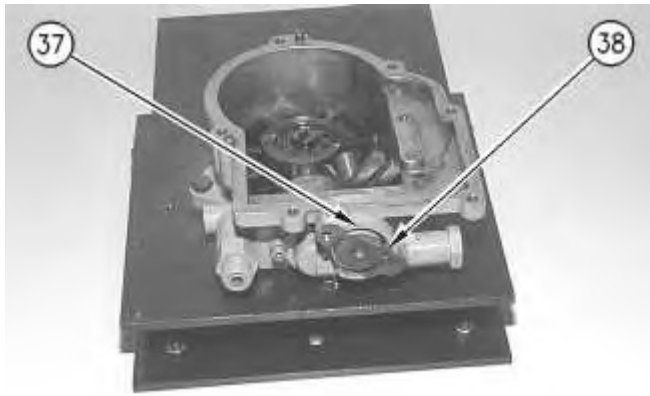

Illustration 33

g00522822

31. Install spring (38) for the throttle lever onto throttle shaft (37) .

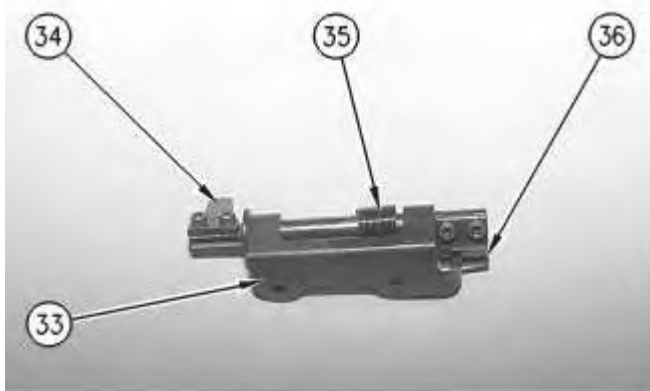

Illustration 34

g00522821

32. Install blade (34) and blade (36) onto shutoff assembly (33). Tighten the bolts that hold blades (34) and (36) to a torque of  $2.0 \pm 0.2 \text{ N}\cdot\text{m}$  ( $18 \pm 2 \text{ lb in}$ ).

**Note:** Spring (35) should not have been removed.

---

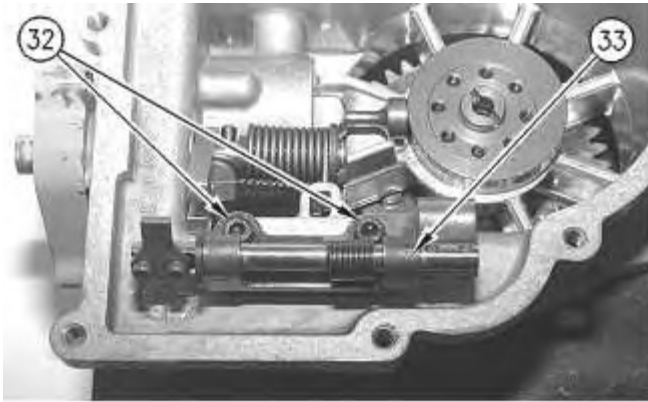

Illustration 35

g00522819

33. Put shutoff assembly (33) into position. Install the two bolts and washers (32) that fasten the shutoff assembly to the governor housing.

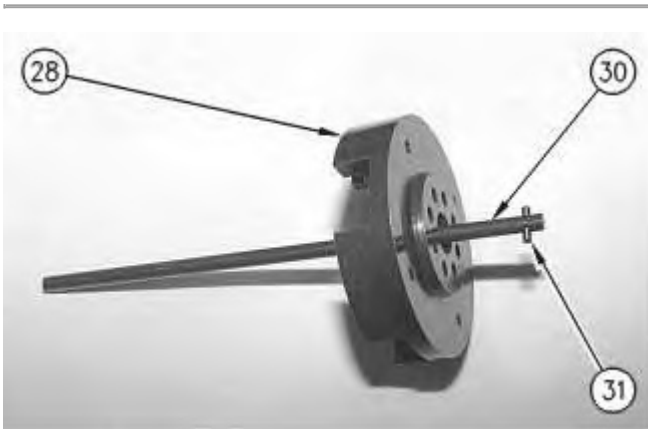

Illustration 36

g00522582

34. Install flyweight carrier (28) onto riser shaft (30). Install pin (31) into riser shaft (30).

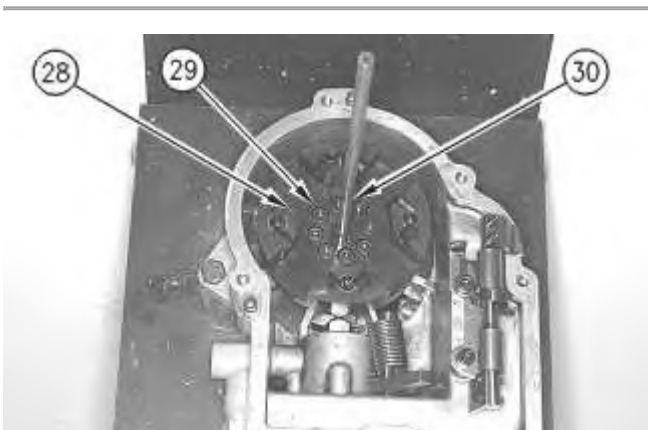

Illustration 37

g00524779

**Note:** Ensure that flyweight carrier (28) and riser shaft (30) are seated properly in the gear carrier before the eight new carrier bolts (29) are tightened.

35. Install flyweight carrier (28) and riser shaft (30) onto the gear carrier. Install eight new carrier bolts (29). Hold flyweight carrier (28) in order to keep the flyweight carrier from rotating. Tighten eight carrier bolts (29) to a torque of  $10 \pm 1$  N·m ( $90 \pm 9$  lb in).

**Note:** Do not reuse eight carrier bolts (29). Replace the used carrier bolts with new carrier bolts.

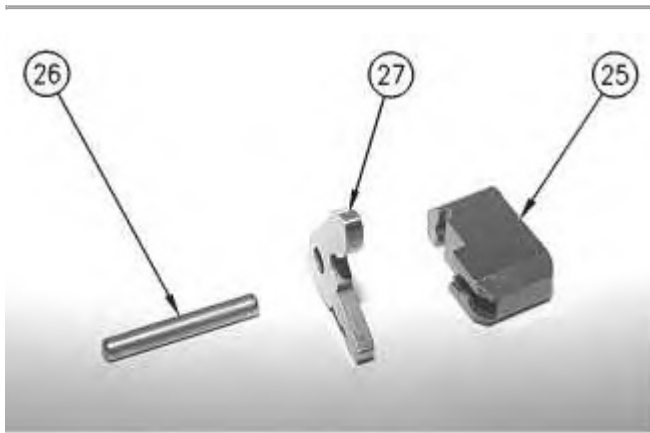

Illustration 38

g00522576

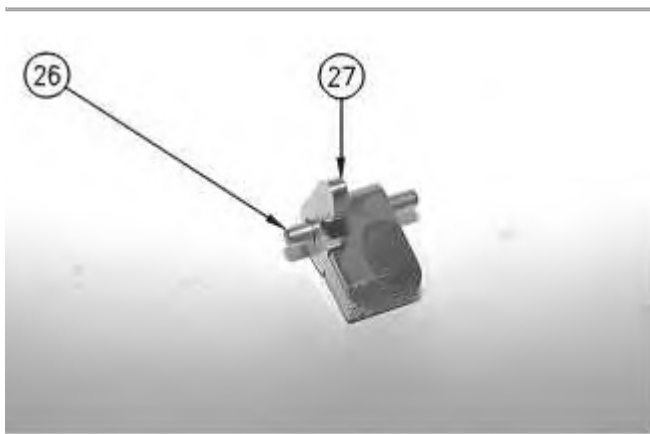

Illustration 39

g00522574

36. Install flyweight (25) onto flyweight toe (27) .
  37. Install flyweight pin (26) through the bore in flyweight (25) and flyweight toe (27) .
-



Illustration 40

g00522537

38. Install flyweights (25) in the original location.

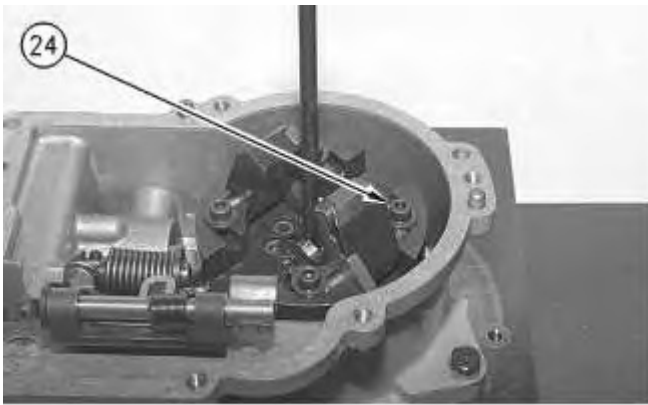

Illustration 41

g00522536

39. Install four bolts and four washers (24) that hold the flyweights in position. Tighten bolts (24) to a torque of  $2.2 \pm 0.2$  N·m ( $19 \pm 2$  lb in).

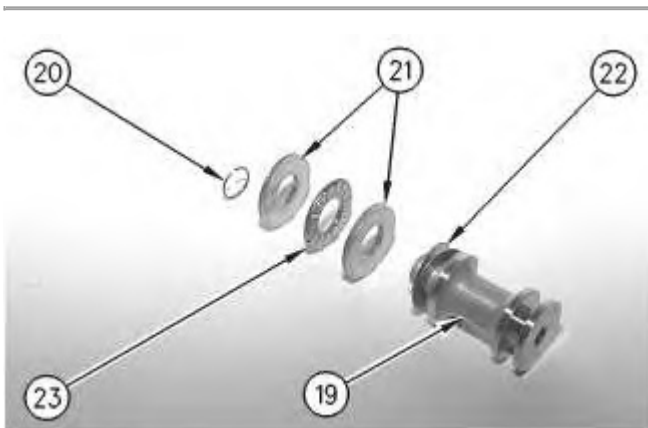

Illustration 42

g00522535

40. Install shims (22), two races (21), and bearing (23) onto riser (19). Do not install retaining ring (20) at this time. Use the procedure that follows to determine the correct number of shims (22) to use on riser (19) .

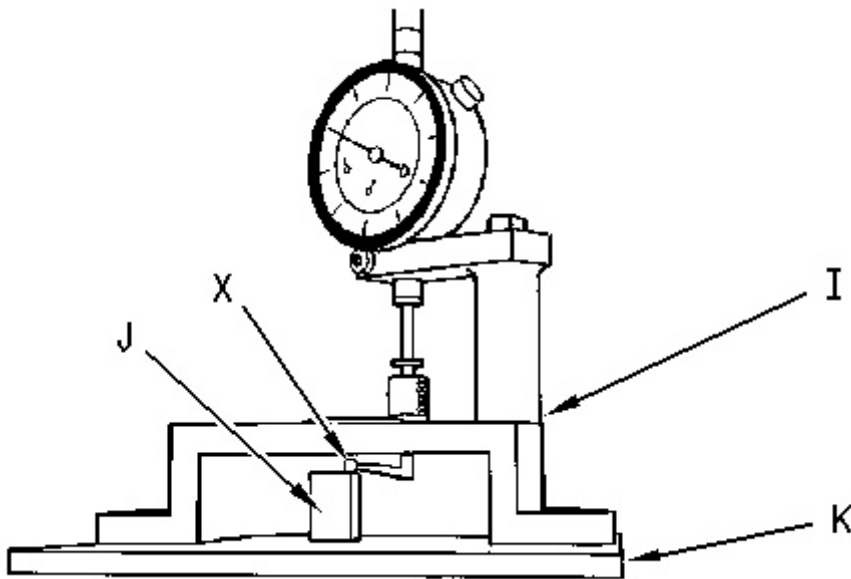

Illustration 43

g00525712

- (I) 1U-7309 Shim Adjustment Tool
- (J) 1U-7313 Gauge Block
- (K) 1U-7312 Calibration Plate
- (X) Ball on the end of the stem
41. Put the **1U-7309** Shim Adjustment Tool (Tool (I) ) in position on top of the **1U-7312** Calibration Plate (Tool (K) ). Place the **1U-7313** Gauge Block (Tool (J) ) on top of Tool (K) and under Tool (I) in order to zero the dial indicator. Lift up and rotate the knurled portion of Tool (I) until ball (X) on the end of the stem rests on Tool (J). The above illustration shows the correct method for setting the dial indicator to zero. Make sure that only the ball touches Tool (J). If the stem before the ball touches Tool (J) an incorrect setting will result.
-

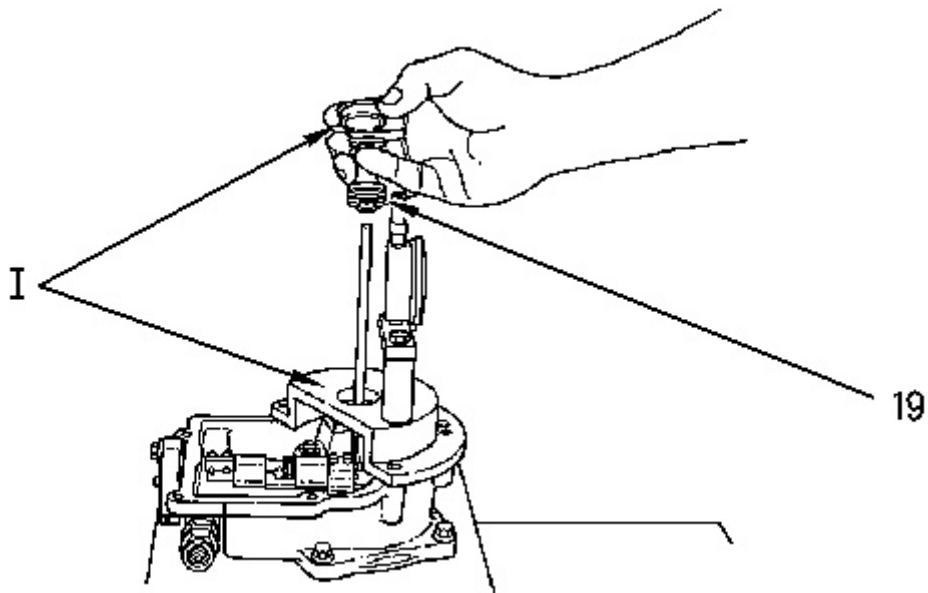

Illustration 44

g00533006

(I) 1U-7309 Shim Adjustment Tool

(19) Riser

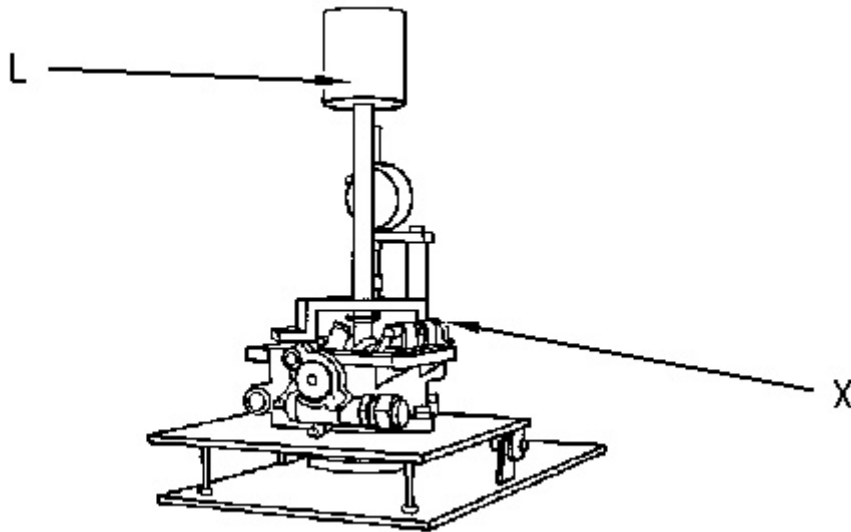

Illustration 45

g00533008

(L) 1U-7314 Weight

(X) Ball on the end of the stem

42. Install Tool (I) on the governor front housing and remove the bushing from the hole in the Tool. Install riser (19) and put the bushing in position on Tool (I). Install the **1U-7314** Weight (Tool (L) ) on top of riser (19) in order to compress the shims. Lift up on the

knurled portion of Tool (I) and use the pointer to place ball (X) in the riser slot. Carefully lower ball (X) onto the slot on the riser and read the dial indicator. The reading on the dial indicator should be  $0.00 \pm 0.08$  mm ( $0.000 \pm 0.003$  inch). Shims must be added in order to increase the reading on the dial indicator. Shims must be removed in order to decrease the reading on the dial indicator.

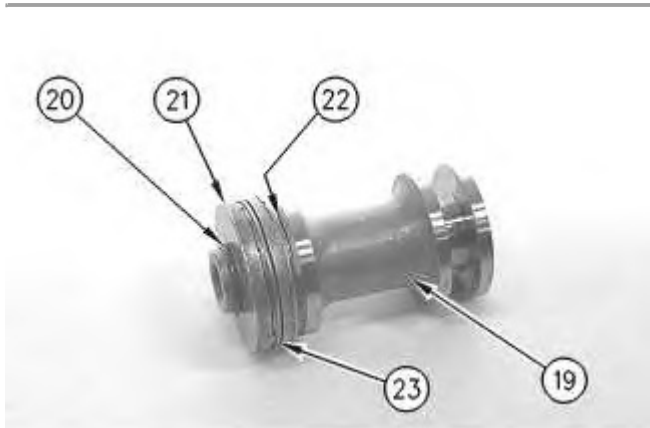

Illustration 46

g00564742

43. When the correct thickness of shims is determined, remove the riser assembly. Remove Tool (A). Install the correct number of shims (22) and install retaining ring (20) .

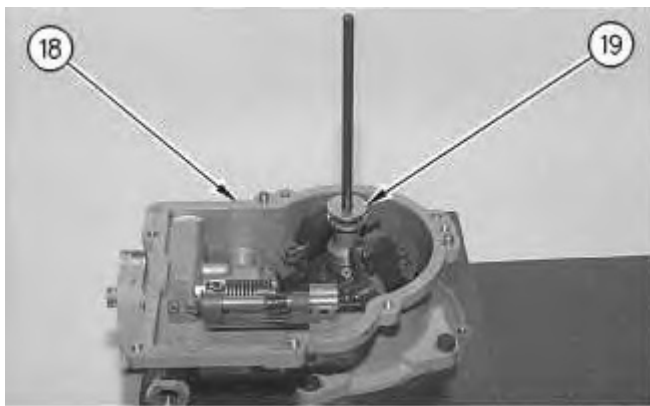

Illustration 47

g00522534

44. Install riser (19) onto the riser shaft and into governor front housing (18) .
-



**Suggest:**

**If the above button click is invalid.**

**Please download this document**

**first, and then click the above link**

**to download the complete manual.**

**Thank you so much for reading**

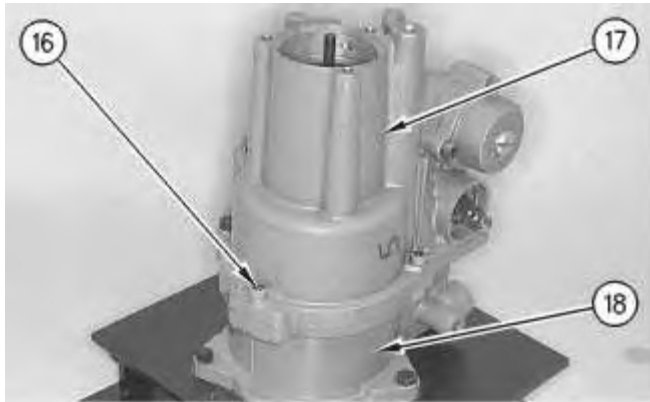

---

Illustration 48

g00522532

45. Put governor rear housing (17) in position on governor front housing (18). Make sure that the fulcrum swivels are engaged with the control lever and the spool. The riser swivel must be engaged in the riser and the shutoff assembly must be rotated out of the way.

**Note:** The swivel in the long arm of the fulcrum lever goes into the spool. The swivel in the short arm of the fulcrum lever goes into the control lever.

46. Install six bolts (16) that hold the governor rear housing and the governor front housing together. Tighten the bolts to a torque of  $12 \pm 3$  N·m ( $9 \pm 2$  lb ft).

**Note:** Look through the hole in the rear cover at the spool on the riser. The spool on the riser should move up and down as the throttle is actuated from low idle to high idle. If the spool on the riser does not move, the front and the governor rear housings are not assembled correctly.

---

**<https://www.ebooklibonline.com>**

Hello dear friend!

Thank you very much for reading.

Enter the link into your browser.

The full manual is available for immediate download.

**<https://www.ebooklibonline.com>**