



# Service Repair Manual

## **Models**

# 962G WHEEL LOADER

---

Previous Screen

Product: WHEEL LOADER

Model: 962G WHEEL LOADER 5RS

Configuration: 962G WHEEL LOADER /COMMAND CONTROL STEE/ 5RS00001-00226 (MACHINE) POWERED BY 3126 ENGINE

## Disassembly and Assembly

### 950G and 962G Wheel Loaders and IT62G Integrated Toolcarrier Power Train

Media Number -SEN1381-10

Publication Date -01/10/2007

Date Updated -25/10/2007

i05754104

## Torque Converter - Assemble

SMCS - 3101-016

### Assembly Procedure

Table 1

Required Tools			
Tool	Part Number	Part Description	Qty
A	439-3940	Link Bracket	3
B	1P-7405	Eyebolt	2
C	2P-8312	Pliers	1
D	-	Loctite 536	-

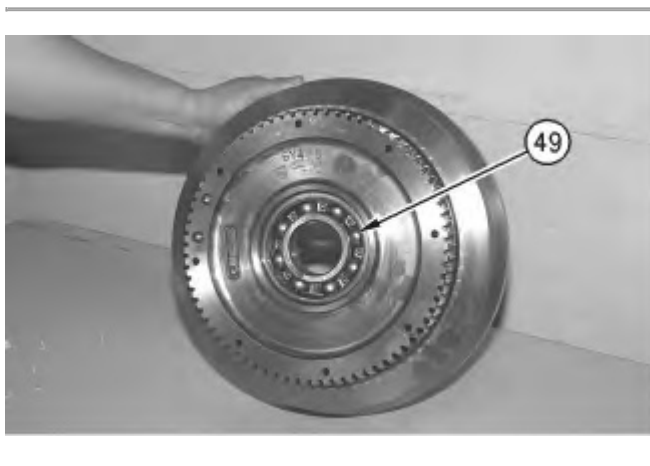

Illustration 1

g00877265

**Note:** The notch on roller bearing (49) must be aligned with locating dowel (48) .

1. Install roller bearing (49) .

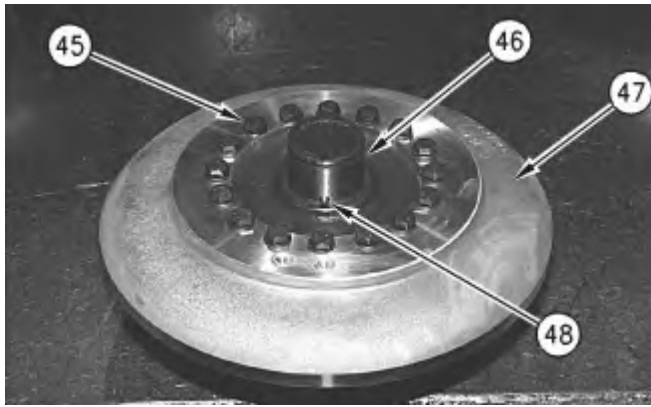

Illustration 2

g00877264

2. Install locating dowel (48) in turbine hub assembly (38) .
3. Install turbine hub assembly (47) to turbine (46) . Install bolts (45) . The torque for bolts (45) is  $60 \pm 7 \text{ N}\cdot\text{m}$  ( $44 \pm 5 \text{ lb ft}$ ).

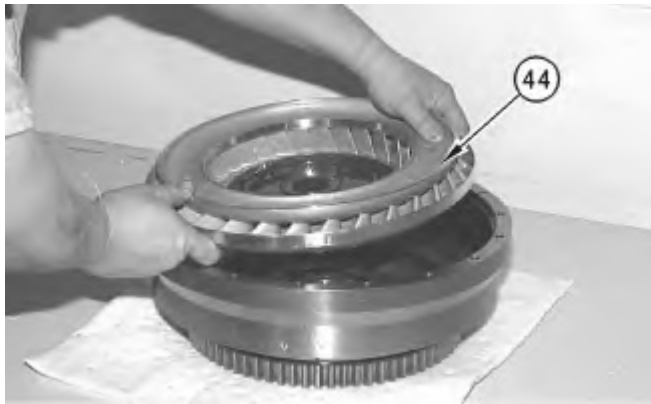

Illustration 3

g00877263

4. Install the impeller housing over turbine assembly (44) , as shown.
-

**<https://www.ebooklibonline.com>**

Hello dear friend!

Thank you very much for reading.

Enter the link into your browser.

The full manual is available for immediate download.

**<https://www.ebooklibonline.com>**

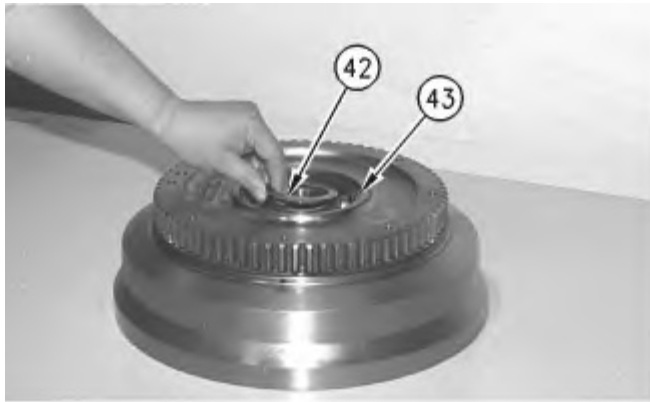

Illustration 4

g00877262

5. Install O-ring seal (43) .
6. Install bearing spacer (42) .

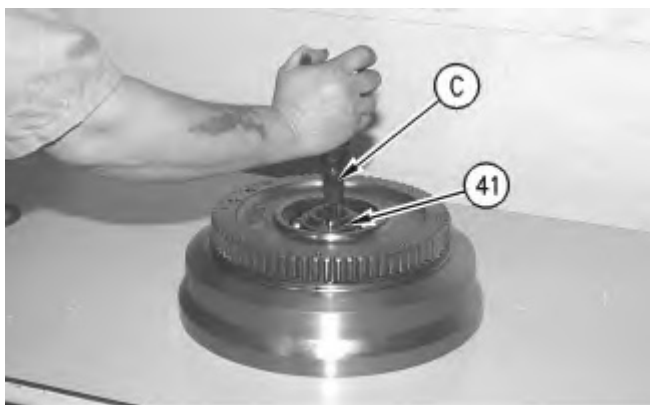

Illustration 5

g00877261

7. Use Tooling (C) in order to install retaining ring (41) .

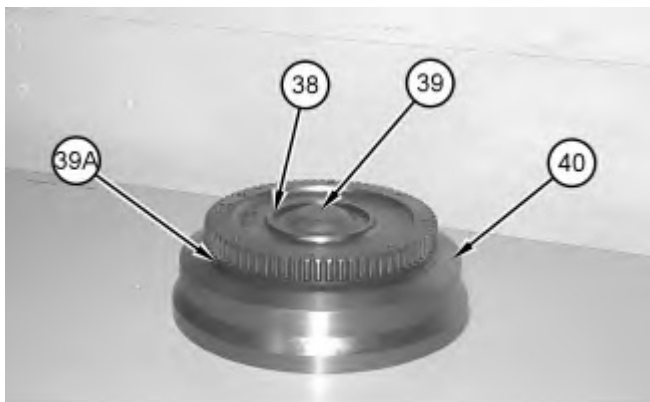

Illustration 6

g01146281

8. Install impeller cover (39) and retaining ring (38) in impeller housing (40) . Install ring (39A) .

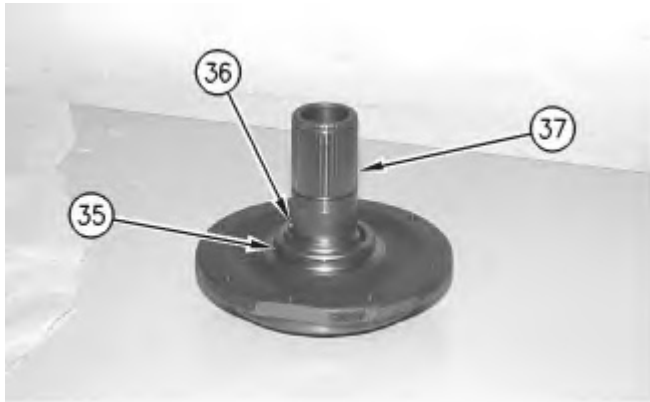

Illustration 7

g00877258

9. Install locating dowel (37) .
10. Install seal ring (36) on carrier assembly (35) .

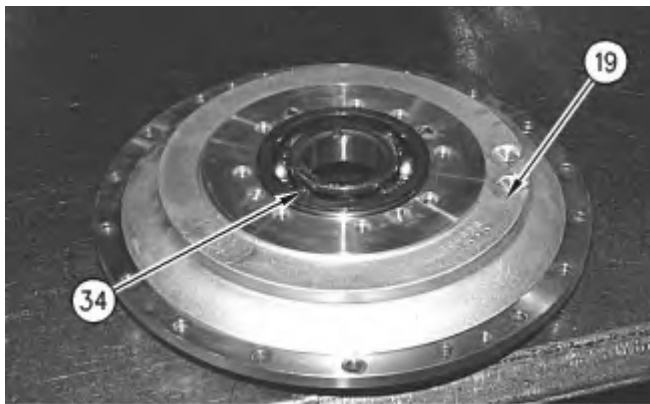

Illustration 8

g00877257

**Note:** The notch in roller bearing (34) must be facing upward.

11. Install roller bearing (34) in torque converter impeller (19) .
-



Illustration 9

g00877250

12. Install drive gear (33) and bolts (32) on the torque converter impeller. The torque for bolts (32) is  $105 \pm 15 \text{ N}\cdot\text{m}$  ( $75 \pm 11 \text{ lb ft}$ ).

**Note:** If the torque converter is equipped with a freewheel stator, continue with Steps 13 through 18.

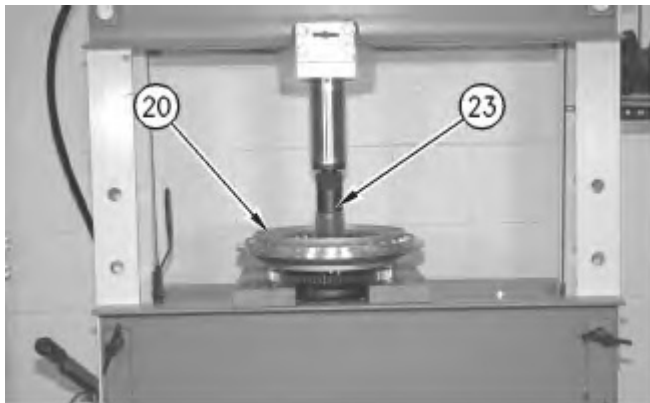
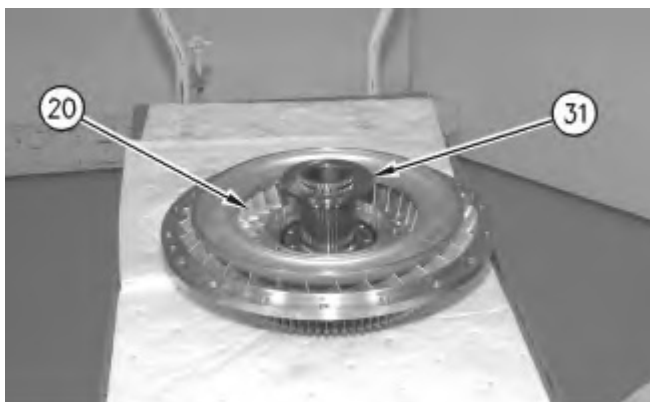

Illustration 10

g00877133

13. Use a suitable press to install carrier shaft (23) in impeller (20) .



14. Install spacer (31) on impeller (20) .

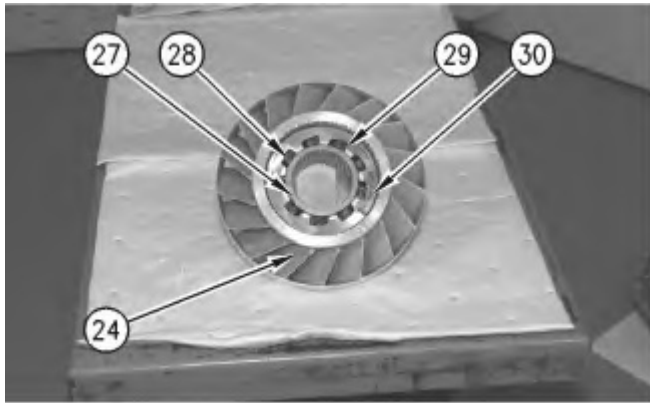

Illustration 12

**Note:** If necessary, Raise the temperature of stator (24) to a maximum temperature of 135 °C (275 °F). Install the cam with the IMPELLER SIDE facing downward. Continue with the installation until freewheel cam (30) contacts the retaining ring (not shown).

15. Install freewheel cam (30) , freewheel springs (29) , freewheel rollers (28) , and bearing race (27) in stator (24) .

**Note:** Install freewheel springs (29) with the maximum number of loops toward the outside diameter of freewheel cam (30) .

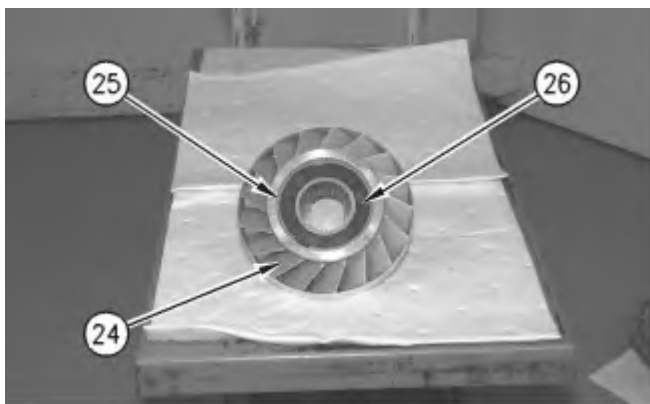

Illustration 13

16. Install washer (26) and snap ring (25) on stator (24) . Repeat the procedure for the opposite side of stator (24) .
-

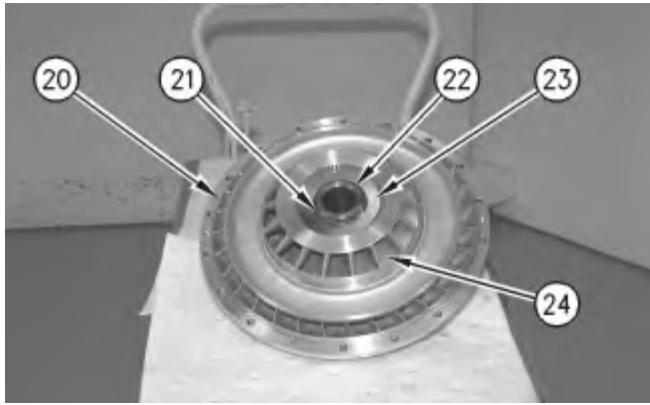

Illustration 14

g00877132

17. Install stator (24) on impeller (20) .
18. Install spacer (22) and snap ring (21) on carrier shaft (23) .



Illustration 15

g00319458

19. Install torque converter impeller (19) on the impeller housing.
20. Install bolts (18) . The torque for bolts (18) is  $60 \pm 7$  N·m ( $44 \pm 5$  lb ft).

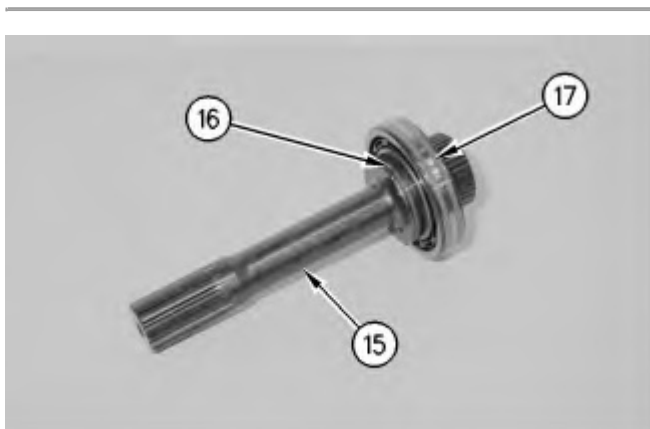

21. Install roller bearing (17) on output shaft (15) .
22. Install seal ring (16) .

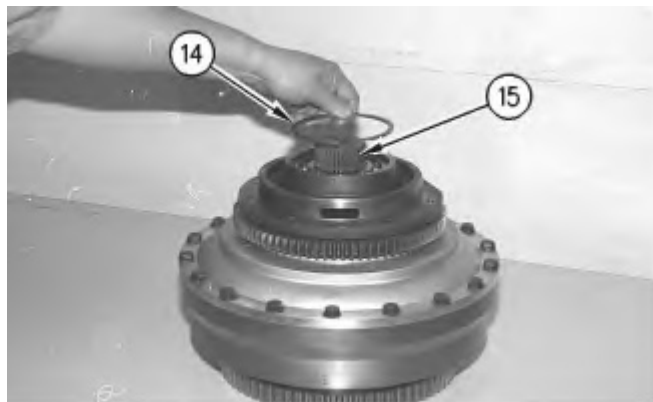

Illustration 17

23. Install output shaft (15) in the carrier assembly.
24. Install retaining ring (14) that secures output shaft (15) .

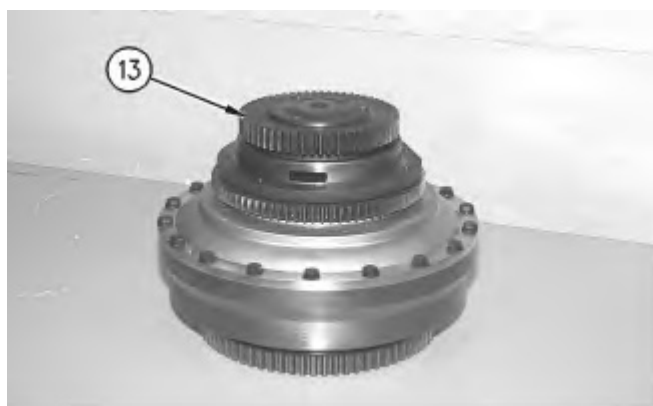

Illustration 18

25. Install drive gear (13) .
-



Illustration 19

g03652860

26. Install pump drive gear (11) to the underside of torque converter housing (1) .



Illustration 20

g03652939

27. Install Tooling (A) and a suitable lifting device to install torque converter housing (1) onto the torque converter assembly. The weight of torque converter housing (1) is approximately 113 kg (250 lb).



Illustration 21

g00319448

28. Install bolts (6) that hold the torque converter to the torque converter housing. The torque for bolts (6) are  $60 \pm 7 \text{ N}\cdot\text{m}$  ( $44 \pm 5 \text{ lb ft}$ ).

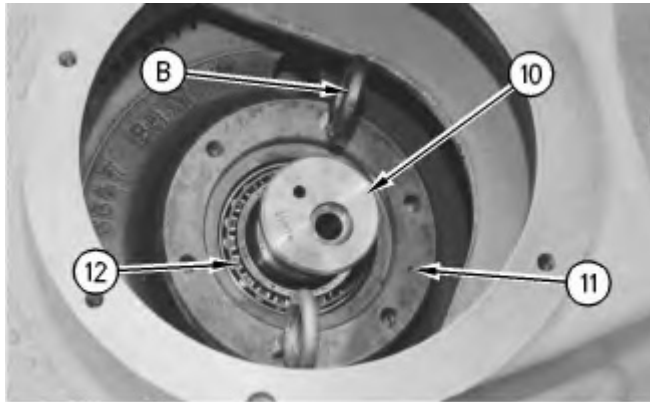

Illustration 22

g00319453

29. Install bearing (12) and drive gear shaft (10) in pump drive gear (11) .
30. Install Tooling (B) on pump drive gear (11) .

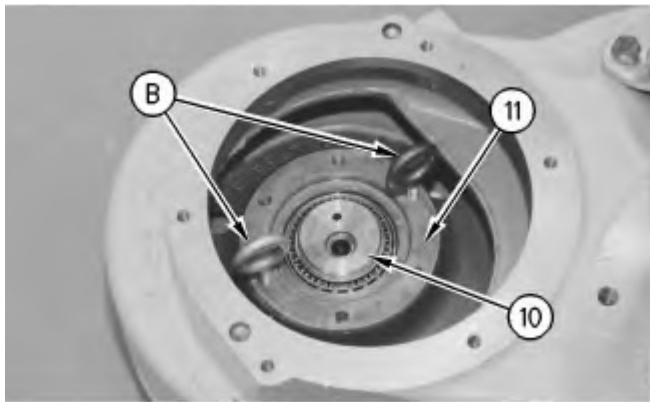

Illustration 23

g00319451

31. Place the assembly in the original position. Make sure that drive gear shaft (10) is in the torque converter housing bore.
32. Remove Tooling (B) from pump drive gear (11) .
-

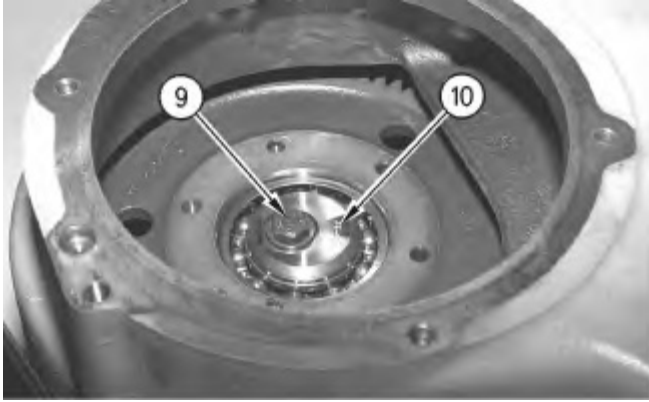

Illustration 24

g00319450

33. Install bolt (9) that holds shaft (10) to torque converter housing (1) . The torque for bolt (9) is  $105 \pm 20 \text{ N}\cdot\text{m}$  ( $75 \pm 15 \text{ lb ft}$ ).

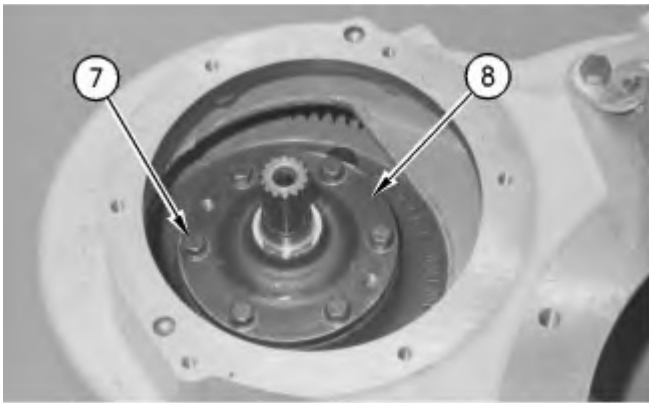

Illustration 25

g00319449

34. Install pump drive flange (8) and bolts (7) . The torque for bolts (7) is  $60 \pm 7 \text{ N}\cdot\text{m}$  ( $44 \pm 5 \text{ lb ft}$ ).

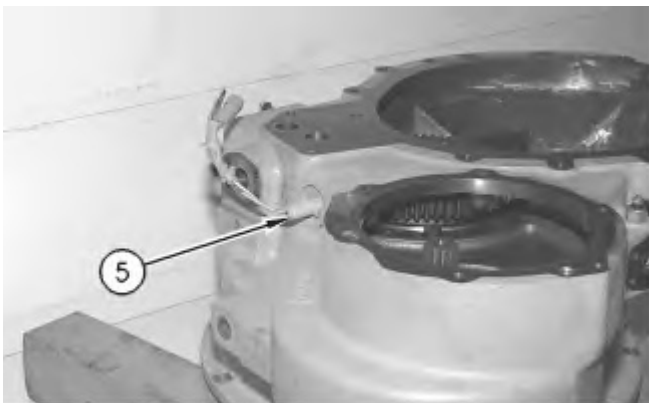

Illustration 26

g00319447

35. Apply Tooling (D) to torque converter speed sensor (5) . Install torque converter speed sensor (5) . Adjust the torque converter speed sensor in order to maintain an air gap of  $0.71 \pm 0.18$  mm ( $0.028 \pm 0.007$  inch). The torque for torque converter speed sensor (5) is  $25 \pm 5$  N·m ( $18 \pm 4$  lb ft).

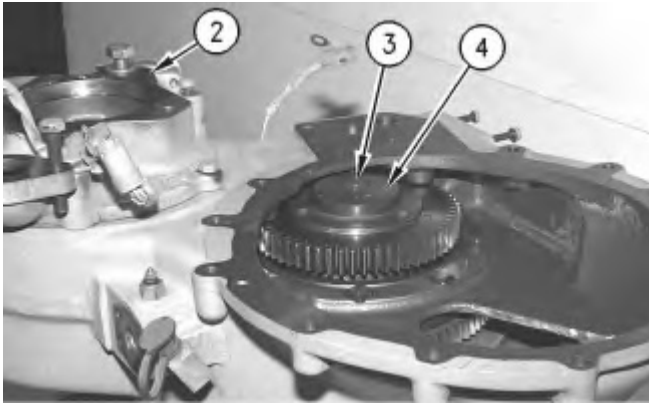

Illustration 27

g00319445

36. Install washer (4) and bolt (3) . The torque for bolt (3) is  $105 \pm 20$  N·m ( $75 \pm 15$  lb ft).
37. Install transmission oil pump (2) . Refer to Disassembly and Assembly, "Transmission Oil Pump - Install".

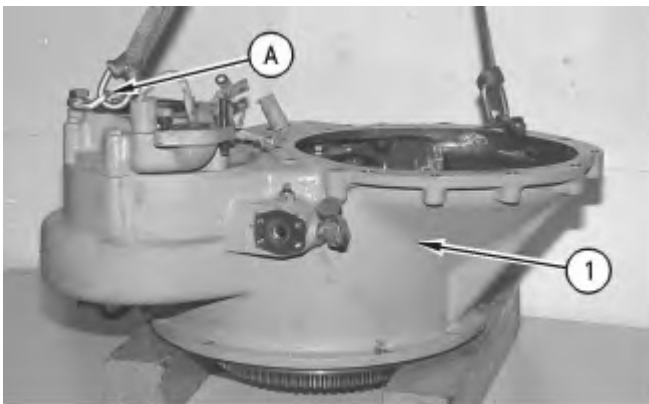

Illustration 28

g00319444

38. Install Tooling (A) and a suitable lifting device to torque converter housing (1) , as shown.

**End By:** Connect the torque converter to the transmission and to the output gears. Refer to Disassembly and Assembly, "Torque Converter to Transmission, Output Gears - Connect".

Previous Screen

Product: WHEEL LOADER

Model: 962G WHEEL LOADER 5RS

Configuration: 962G WHEEL LOADER /COMMAND CONTROL STEE/ 5RS00001-00226 (MACHINE) POWERED BY 3126 ENGINE

**Disassembly and Assembly**

**950G and 962G Wheel Loaders and IT62G Integrated Toolcarrier Power Train**

Media Number -SEN1381-10

Publication Date -01/10/2007

Date Updated -25/10/2007

i00731694

**Transmission from Output Transfer Gears - Separate**

SMCS - 3002-076

**Separation Procedure**

Table 1

Required Tools			
Tool	Part Number	Part Description	Qty
A	138-7575	Link Bracket	1

**Start By:**

- A. Separate the torque converter from the transmission. Refer to Disassembly and Assembly, "Torque Converter from Transmission, Output Transfer Gears - Separate".

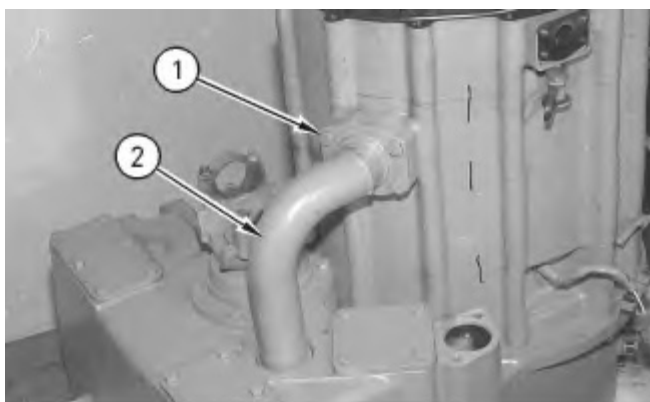

Illustration 1

g00326943

- 1. Remove bolts (1) and drain tube assembly (2) .

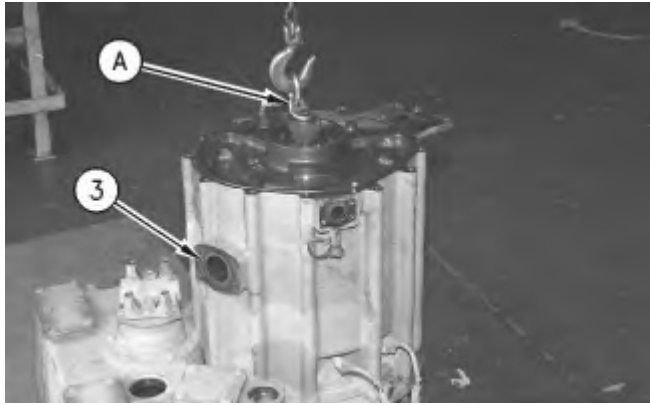

Illustration 2

g00326944

2. Attach Tooling (A) to the transmission planetary group, as shown. Attach a suitable lifting chain and a hoist to Tooling (A) .
3. Remove O-ring seal (3) .

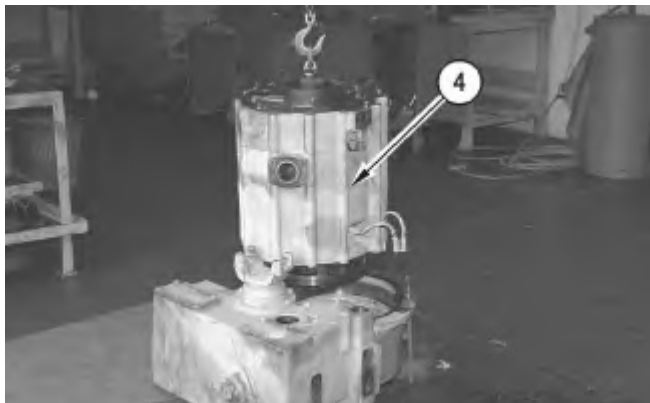

Illustration 3

g00336158

4. Use the hoist to separate transmission planetary group (4) from the output transfer gear case. The weight of the transmission planetary group is 545 kg (1200 lb).

[Previous Screen](#)

Product: WHEEL LOADER

Model: 962G WHEEL LOADER 5RS

Configuration: 962G WHEEL LOADER /COMMAND CONTROL STEE/ 5RS00001-00226 (MACHINE) POWERED BY 3126 ENGINE

## Disassembly and Assembly

### 950G and 962G Wheel Loaders and IT62G Integrated Toolcarrier Power Train

Media Number -SEN1381-10

Publication Date -01/10/2007

Date Updated -25/10/2007

i04904939

## Transmission Planetary - Disassemble

SMCS - 3160-015

### Disassembly Procedure

Table 1

Required Tools			
Tool	Part Number	Part Description	Qty
A	138-7575	Link Bracket	2
B	1P-2420	Transmission Repair Stand	1
C	136-1452	Retaining Ring Pliers As	1
D	5P-5197	Retaining Ring Pliers As	1
E	1P-1863	Retaining Ring Pliers As	1
F	1P-0520	Driver Gp	1
G	8B-7551	Bearing Puller Gp	1

#### Start By:

- A. Separate the torque converter from the transmission.
-

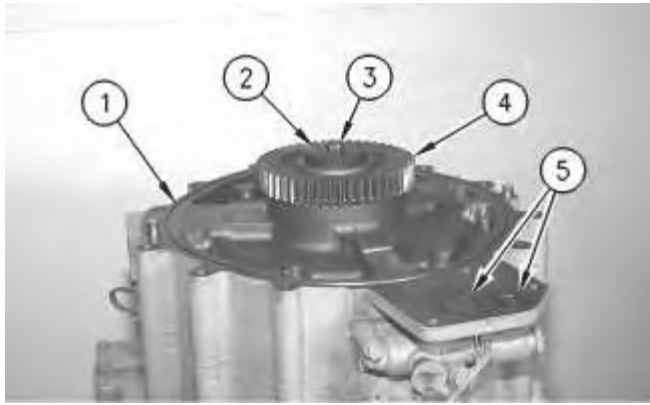

Illustration 1

g00324683

1. Remove O-ring seals (1) and (5) from the housing.
2. Remove bolt (3) , retainer (2) , and drive gear (4) from the end of the input shaft.

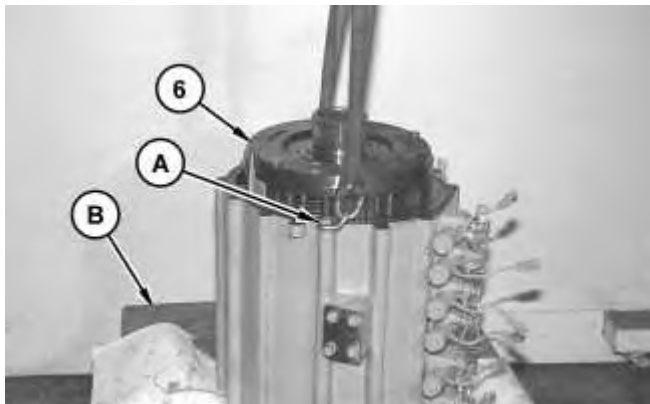
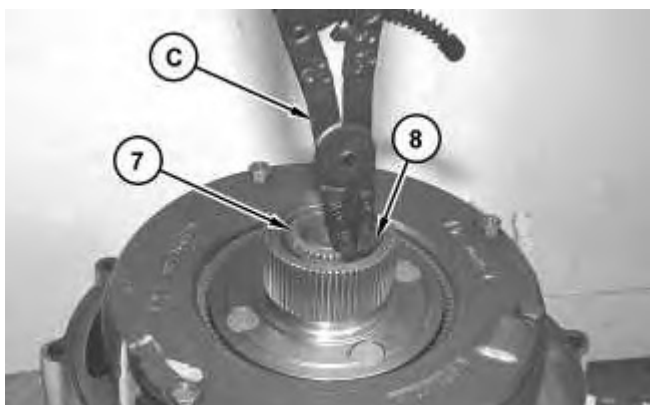

Illustration 2

g01174662

3. Use Tooling (A) and a suitable lifting device to position the transmission on Tooling (B) , as shown.



4. Use Tooling (C) to remove retaining ring (8) from output shaft (7) .



Illustration 4

g00324690

5. Remove four bolts (9) and No. 6 clutch housing (6) . Mark the location of the long bolt.

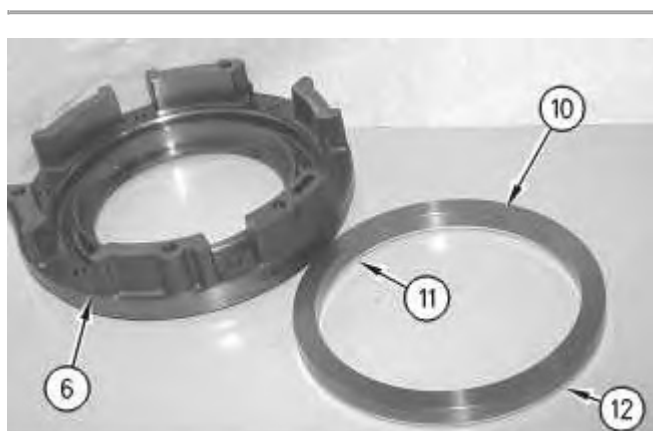

Illustration 5

g00324691

6. Remove clutch piston (10) from No. 6 clutch housing (6) .
  7. Remove seal rings (11) and (12) from clutch piston (10) .
-



---

Illustration 6

g03078253



---

Illustration 7

g03063016

8. Remove upper clutch plate (13) , and remove springs (14) and remove reaction dowels (15) .



---

Illustration 8

g03063037

9. Remove clutch plates (16) and friction discs (17) .
-



Illustration 9

g03063156

10. Remove ring gear (18) , and remove O-ring seal (19) .



Illustration 10

g03063116

11. Remove carrier assembly (20) .



Illustration 11

g03063218

12. Remove metal seal ring (21) from the carrier assembly.

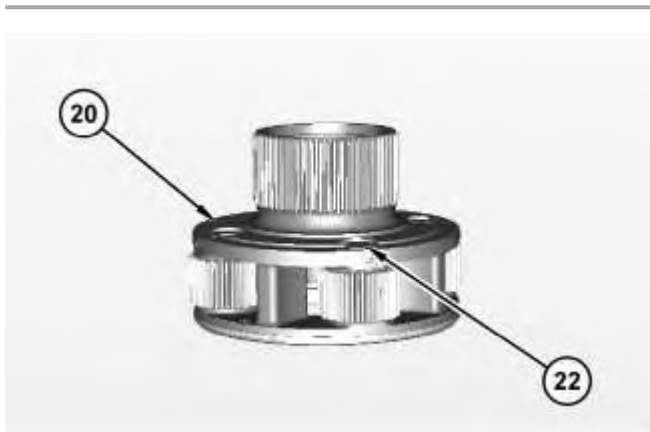

Illustration 12

g03063497

13. Use a suitable hammer and a punch to push the spring pins through carrier assembly (20) and into planetary shafts (22) .

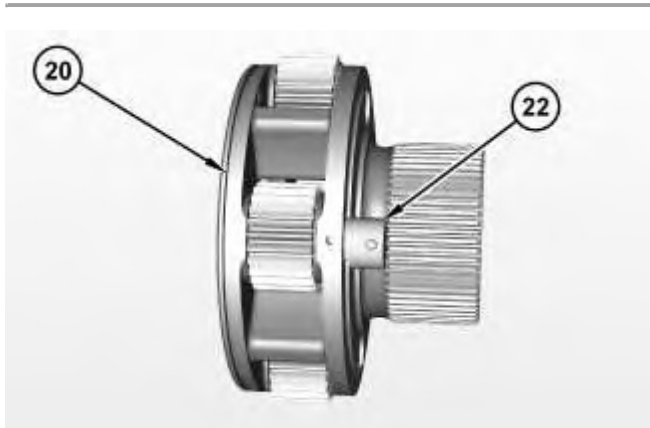
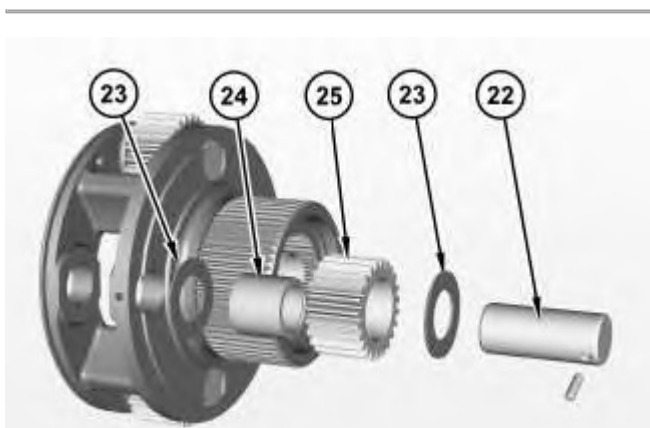

Illustration 13

g03066604

14. Use a suitable hammer and a punch to remove planetary shafts (22) from carrier assembly (20) .



15. Remove thrust discs (23) , and remove planetary gears (25) , and remove bearings (24) from the carrier assembly. Remove the spring pins from planetary shafts (22) .

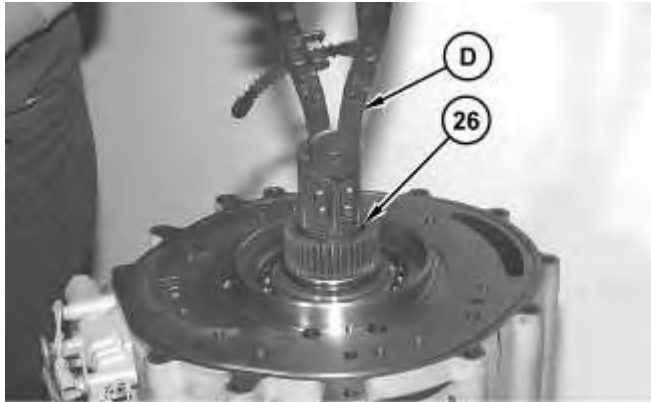

Illustration 15

16. Use Tooling (D) to remove retaining ring (26) from the output shaft.

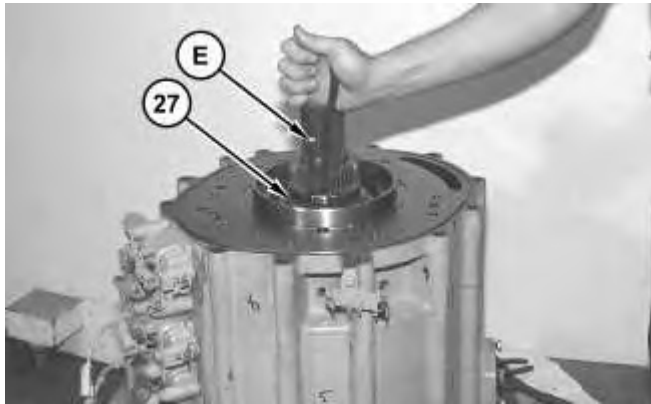

Illustration 16

17. Use Tooling (E) to remove retaining ring (27) from the output shaft.
-

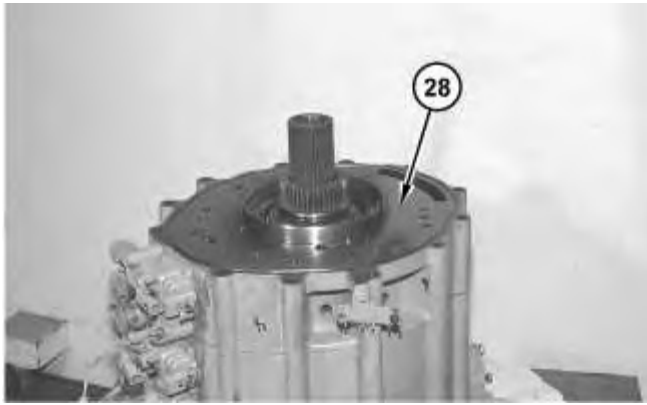

Illustration 17

g01174668

18. Use Tooling (A) and a suitable lifting device to remove housing (28) and the O-ring seal. The weight of housing (28) is approximately 29 kg (64 lb).

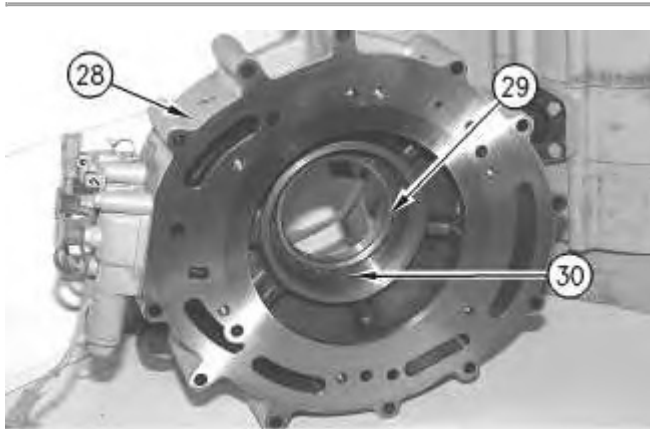

Illustration 18

g00339593

19. Remove retaining ring (30) and bearing (29) from housing (28) .

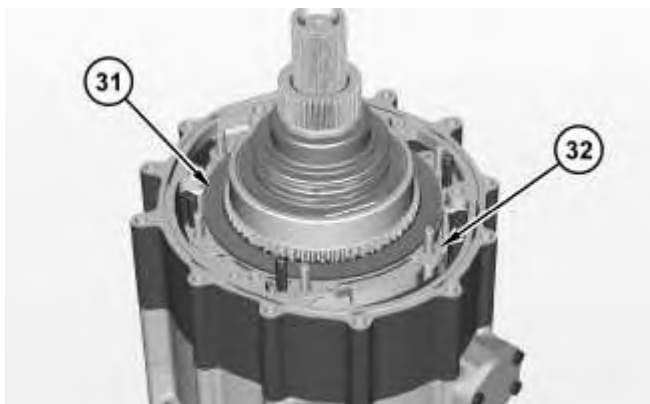

Illustration 19

g03078198

20. Remove friction discs (31) and clutch plates (32) and remove the springs.

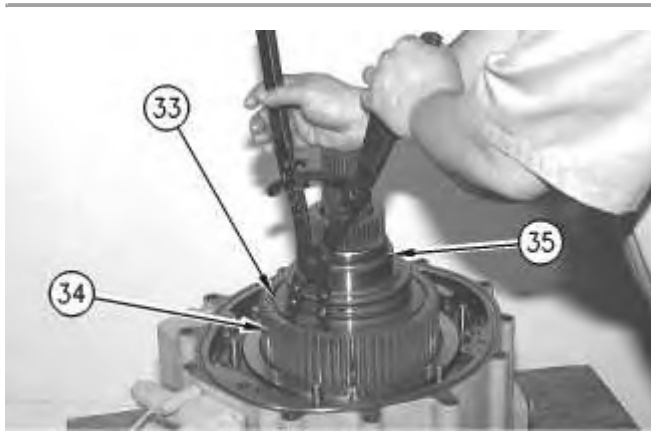

Illustration 20

g00324823

21. Use Tooling (C) to compress retaining ring (33) . Remove clutch housing (35) from ring gear (34) .



Illustration 21

g00324824

22. Use Tooling (C) to remove retaining ring (33) from clutch housing (35) .

---

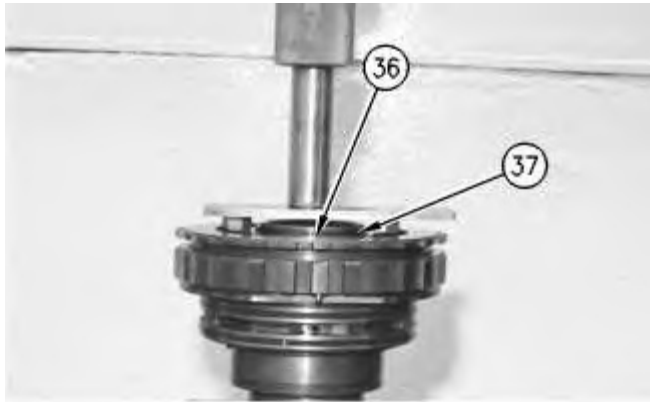

Illustration 22

g00324825

23. Use steel spacers and a press to apply pressure to retainer plate (36) . Remove retaining ring (37) from the clutch housing.

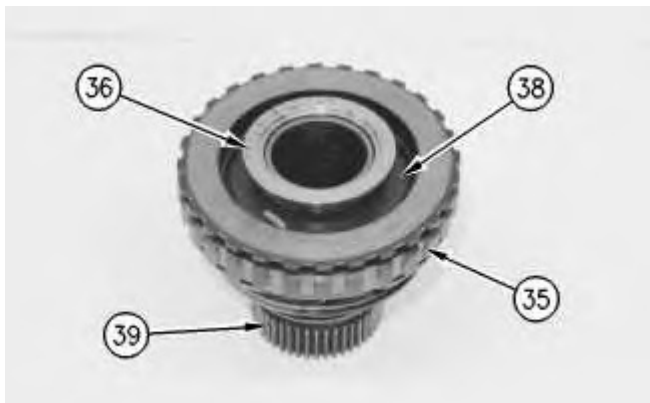
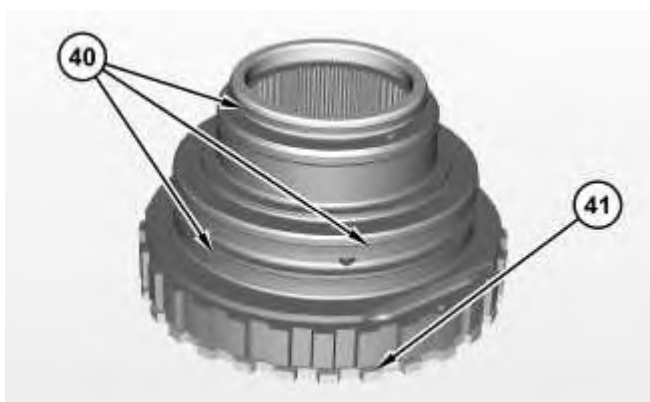

Illustration 23

g00324826

24. Remove retainer plate (36) from sun gear shaft (39) . Remove disc springs (38) from clutch housing (35) .
25. Remove clutch housing (35) from sun gear shaft (39) .





**Suggest:**

**If the above button click is invalid.**

**Please download this document**

**first, and then click the above link**

**to download the complete manual.**

**Thank you so much for reading**

26. Remove seal rings (40) and piston (41) from the clutch housing.

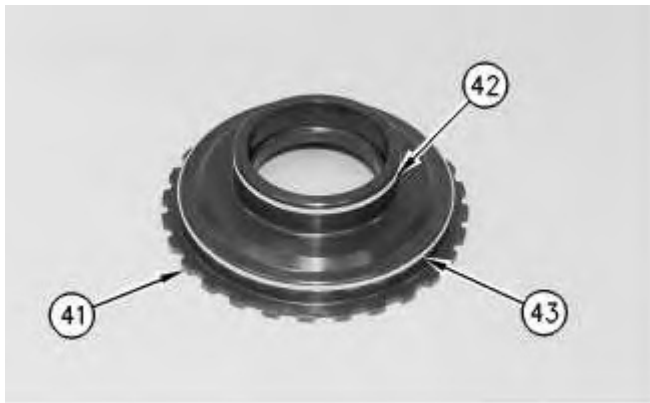

Illustration 25

27. Remove seal ring (42) and seal ring (43) from piston (41) .



Illustration 26

28. Remove retaining ring (44) from the output shaft.
-

**<https://www.ebooklibonline.com>**

Hello dear friend!

Thank you very much for reading.

Enter the link into your browser.

The full manual is available for immediate download.

**<https://www.ebooklibonline.com>**