



# Service Repair Manual

## **Models**

# 930R WHEEL LOADER

---

Previous Screen

Product: WHEEL LOADER

Model: 930R WHEEL LOADER 57Z

Configuration: 930R WHEEL LOADER 57Z03017-03999 (MACHINE) POWERED BY 3304 ENGINE

**Disassembly and Assembly  
3304B and 3306B Engines for Caterpillar Built Machines**

Media Number -SEN5598-09

Publication Date -01/01/2013

Date Updated -25/01/2013

i00990465

## Crankshaft Front Seal - Remove

SMCS - 1160-011

### Removal Procedure

Table 1

Required Tools			
Tool	Part Number	Part Description	Qty
A	1P-0510	Driver Group	1
B	5P-7315	Wear Sleeve Distorter Ring	1
C	5P-7312	Seal Distorter	1

**Start By:**

- A. Remove the vibration damper and the pulley. Refer to Disassembly and Assembly, "Vibration Damper and Pulley - Remove and Install".

---

**NOTICE**

**Keep all parts clean from contaminants.**

**Contaminants may cause rapid wear and shortened component life.**

---



---

**NOTICE**

**Care must be taken to ensure that fluids are contained during performance of inspection, maintenance, testing, adjusting and repair of the machine. Be prepared to collect the fluid with suitable containers before opening any compartment or disassembling any component containing fluids.**

**Refer to Special Publication, NENG2500, "Caterpillar Tools and Shop Products Guide", for tools and supplies suitable to collect and contain fluids in Caterpillar machines.**

**Dispose of all fluids according to local regulations and mandates.**

---

**Note:** When a crankshaft seal is replaced, the wear sleeve must also be replaced.

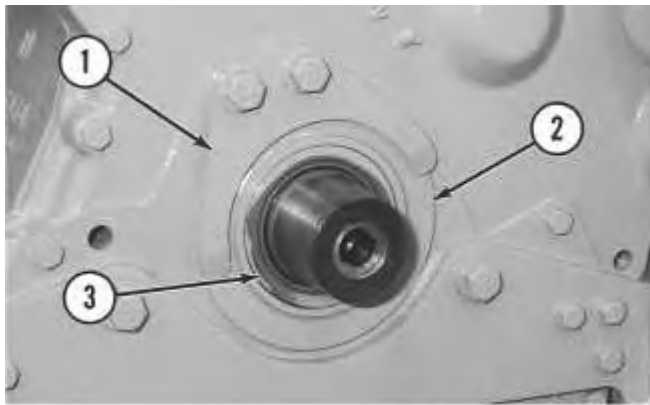

---

Illustration 1

g00504503

1. Remove the two bolts, washers, spacers and clamp (1) that holds crankshaft seal adapter (2) in position. Remove crankshaft seal adapter (2) and the O-ring seal from the engine.
  2. Use Tool (A) and a press to remove the crankshaft seal from crankshaft seal adapter (2) .
  3. Install the O-ring seal and crankshaft seal adapter (2) on the engine. Install the two bolts, washers, spacers and clamp (1) to hold crankshaft seal adapter (2) in position.
-

**<https://www.ebooklibonline.com>**

Hello dear friend!

Thank you very much for reading.

Enter the link into your browser.

The full manual is available for immediate download.

**<https://www.ebooklibonline.com>**

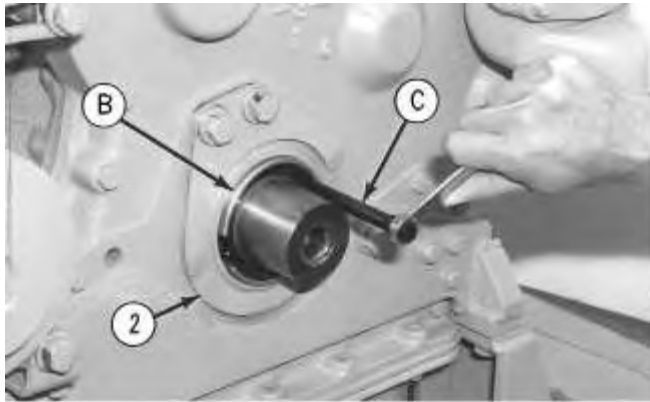

Illustration 2

g00510634

4. Install Tool (B) in the bore of seal adapter (2), as shown.

---

### NOTICE

**Care should be taken to ensure that the seal distorter does not cut through the wear sleeve. Damage to the crankshaft surface may occur leading to possible oil seal leaks.**

---

5. Install Tool (C) between Tool (B) and the wear sleeve. Turn Tool (C) with a wrench, until the edge of the tool makes a flat crease in the wear sleeve. Repeat this process until there are enough creases in the wear sleeve in order to allow the wear sleeve to be slipped off the end of the crankshaft.
6. Remove Tools (B) and (C). Remove the wear sleeve by hand.

[Previous Screen](#)

Product: WHEEL LOADER

Model: 930R WHEEL LOADER 57Z

Configuration: 930R WHEEL LOADER 57Z03017-03999 (MACHINE) POWERED BY 3304 ENGINE

## Disassembly and Assembly 3304B and 3306B Engines for Caterpillar Built Machines

Media Number -SEN5598-09

Publication Date -01/01/2013

Date Updated -25/01/2013

i06015907

# Crankshaft Front Seal - Install

SMCS - 1160-012

## Installation Procedure

Table 1

Required Tools			
Tool	Part Number	Part Description	Qty
A	4C-8982 <sup>(1)</sup>	Installer	1
	438-9547 <sup>(2)</sup>	Installer	1
	7F-8022	Bolt	1

<sup>(1)</sup> Use to install 9Y-9895 seal

<sup>(2)</sup> Use to install 362-8853 seal

---

### NOTICE

**Keep all parts clean from contaminants.**

**Contaminants may cause rapid wear and shortened component life.**

---

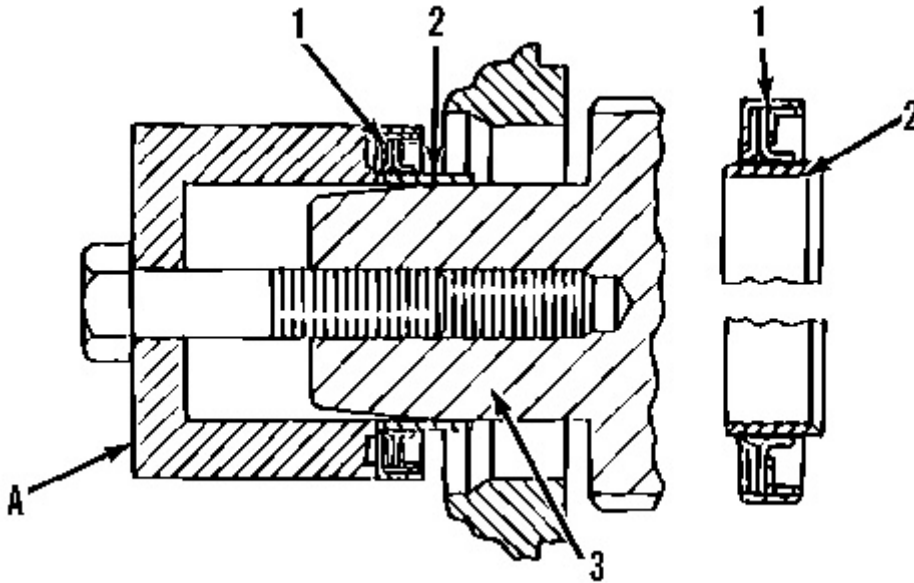

Illustration 1

g00488110

**Note:** Once the seal and the wear sleeve are separated, these components cannot be used again. Refer to Special Instruction, SMHS8508 before the seal is serviced.

**Note:** Do not use any type of lubricant during the installation of the crankshaft seal and wear sleeve.

**Note:** Before installing the wear sleeve, inspect the crankshaft for scratches or any distortion on the surface of the crankshaft that may lead to an out of round condition. Use a polishing cloth to clean the imperfections on the crankshaft.

1. Install crankshaft front seal (1) and wear sleeve (2) with Tool (A) , as follows:
  - a. Use **4C-9500** Quick Cure Primer to clean the outside diameter of crankshaft (3) and the inside diameter of wear sleeve (2) .
  - b. Apply **4C-9507** Compound to the outside diameter of crankshaft (3) and the inside diameter of wear sleeve (2) .
  - c. Place crankshaft front seal (1) and wear sleeve (2) on the front of crankshaft (3) .  
Install Tool (A) and tighten until the inside surface of the Installer comes in contact with the end of the crankshaft.

**End By:** Install the vibration damper and the pulley. Refer to Disassembly and Assembly, "Vibration Damper and Pulley - Remove and Install".

Previous Screen

Product: WHEEL LOADER

Model: 930R WHEEL LOADER 57Z

Configuration: 930R WHEEL LOADER 57Z03017-03999 (MACHINE) POWERED BY 3304 ENGINE

**Disassembly and Assembly  
3304B and 3306B Engines for Caterpillar Built Machines**

Media Number -SEN5598-09

Publication Date -01/01/2013

Date Updated -25/01/2013

i02107004

## Gear Group (Front) - Remove

SMCS - 1206-011

### Removal Procedure

Table 1

Required Tools			
Tool	Part Number	Part Description	Qty
A	1P-0510	Driver Group	1

**Start By:**

- A. Remove the automatic timing advance unit. Refer to Disassembly and Assembly, "Automatic Timing Advance - Remove".

---

**NOTICE**

**Keep all parts clean from contaminants.**

**Contaminants may cause rapid wear and shortened component life.**

---

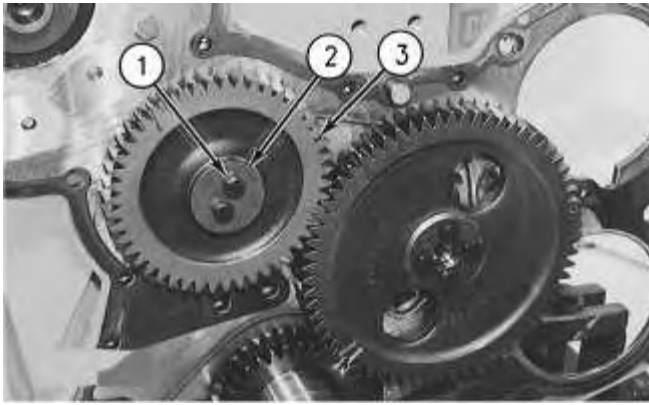

Illustration 1

g00476414

1. Remove bolts (1), plate (2), and fuel pump idler gear (3) .

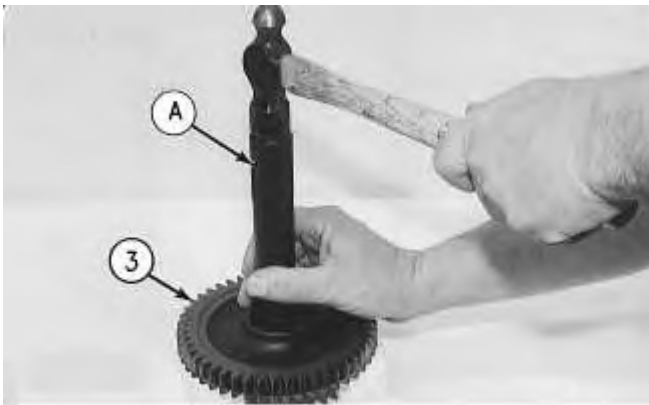

Illustration 2

g00476416

2. Remove the bearing from fuel pump idler gear (3) with Tooling (A) .

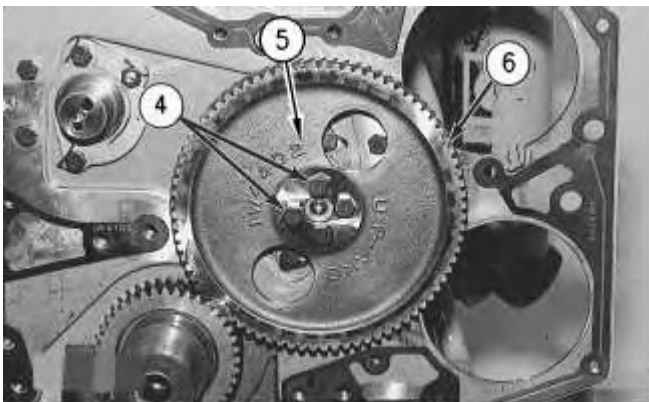

Illustration 3

g00476417

3. Remove bolts (4), plate (5), and camshaft gear (6) .

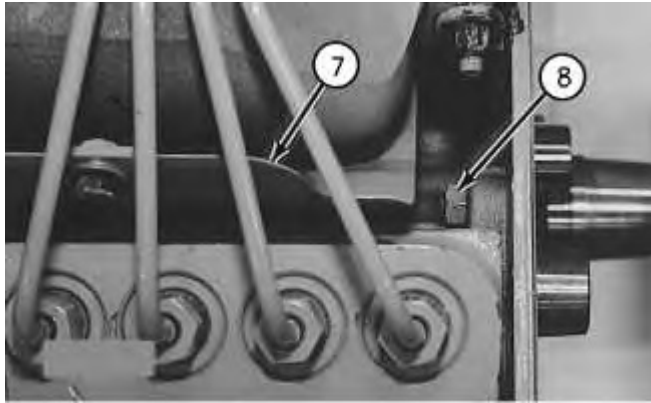

Illustration 4

g00476418

4. Remove the bolts that hold shield (7) in position between the fuel pump and the exhaust manifold. Slide the shield backward from the timing cover plate.
5. Remove nuts (8) .

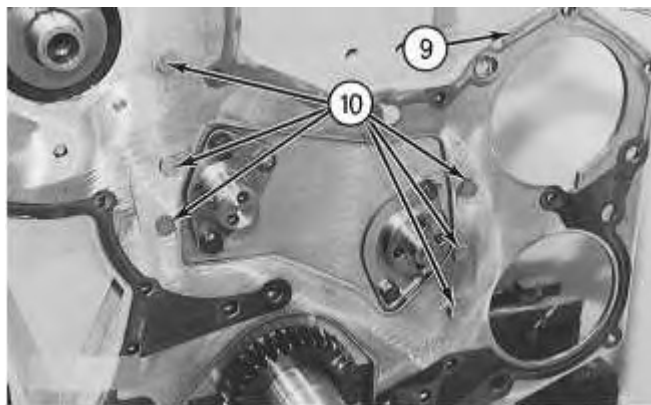

Illustration 5

g00476419

6. Remove bolts (10). Remove timing gear plate (9) and the gasket.

Previous Screen

Product: WHEEL LOADER

Model: 930R WHEEL LOADER 57Z

Configuration: 930R WHEEL LOADER 57Z03017-03999 (MACHINE) POWERED BY 3304 ENGINE

**Disassembly and Assembly  
3304B and 3306B Engines for Caterpillar Built Machines**

Media Number -SEN5598-09

Publication Date -01/01/2013

Date Updated -25/01/2013

i02107019

## Gear Group (Front) - Install

SMCS - 1206-012

### Installation Procedure

Table 1

Required Tools			
Tool	Part Number	Part Description	Qty
A	1P-0510	Driver Group	1
B	9S-3263	Thread Lock Compound	1

---

#### NOTICE

**Keep all parts clean from contaminants.**

**Contaminants may cause rapid wear and shortened component life.**

---

**Note:** Check the condition of the gaskets and the O-ring seals. If the gaskets or the O-ring seals are worn or damaged, use new parts for replacement.

1. Clean the old gasket from the contact surfaces of the timing gear plate and the cylinder block. Install a new gasket on the cylinder block. Cut the gasket even with the bottom face of the cylinder block.
-

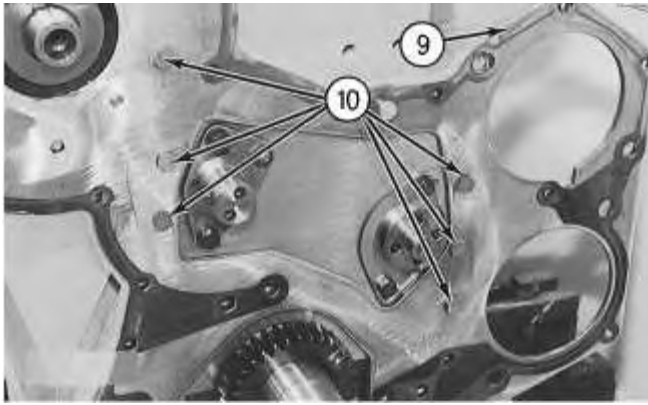

Illustration 1

g00476419

---

## NOTICE

**The bolts that hold the timing gear plate in position on the cylinder block should have a reduced bolt head thickness. The reduced bolt head thickness is needed for clearance for the gears.**

---

2. Ensure that the O-ring seals are in position on the end of the fuel injection pump housing. Put timing gear plate (9) in position on the cylinder block. Install bolts (10) .

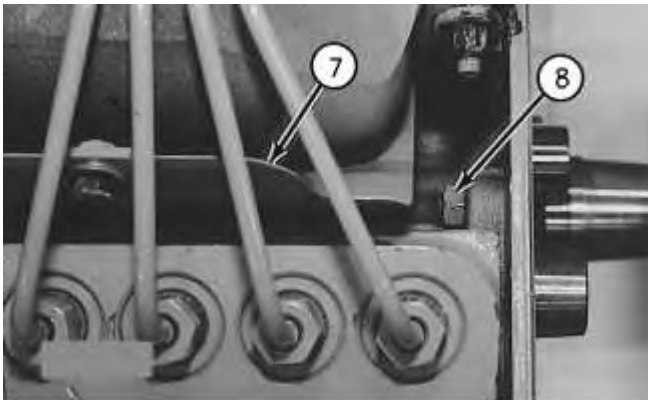

Illustration 2

g00476418

3. Install shield (7). Install nuts (8) .

**Note:** After the timing gear plate is installed, ensure that the rack is free to move in the fuel injection pump housing. The O-ring seal on the drive end of the fuel injection pump housing can hold the rack. This can help prevent free rack movement. Rack movement can be seen through a hole in the timing gear plate just above the mounting of the fuel pump gear. If the rack does not move freely, remove the timing gear plate and check the O-ring seal on the drive end of the fuel injection pump housing.

## WARNING

If the rack does not move freely, the engine can over speed and be damaged. Serious personal injury may result.

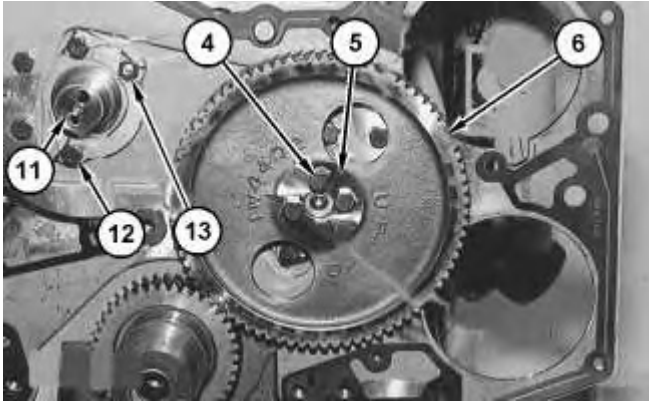

Illustration 3

g01072912

**Note:** If idler gear shaft (11) for the fuel pump idler gear was removed, use Tooling (B) on the threads of bolts (12) and nut (13) before reinstalling idler gear shaft (11). Tighten bolts (12) and nut (13) to a torque of  $50 \pm 10$  N·m ( $37 \pm 7$  lb ft).

- Put camshaft gear (6) and plate (5) in position on the engine. Align the Mark "C" on the camshaft gear with the Mark "C" on the crankshaft gear. Install bolts (4) and tighten bolts (4) to a torque of  $55 \pm 7$  N·m ( $41 \pm 5$  lb ft).

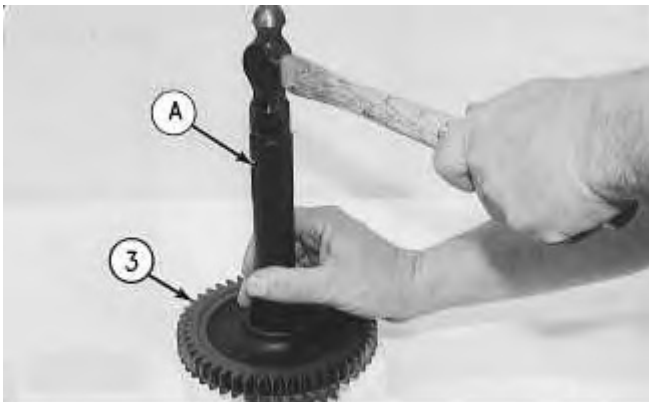

Illustration 4

g00476416

- Use Tooling (A) in order to install the bearing in fuel pump idler gear (3). The end of the bearing must be  $3.00 \pm 0.25$  mm ( $.118 \pm .010$  inch) below the face of the hub of the fuel pump idler gear.

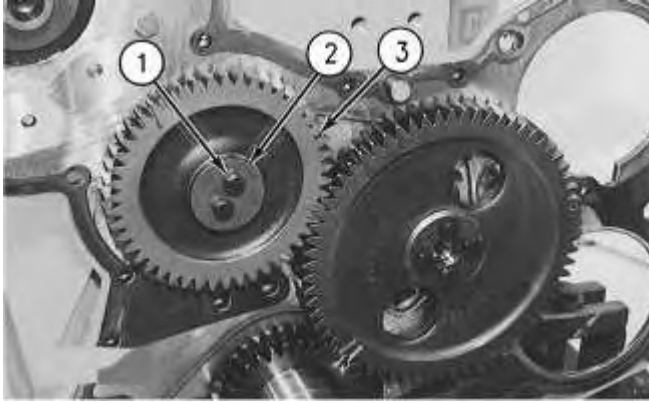

Illustration 5

g00476414

6. Ensure that the oil hole in the shaft for fuel pump idler gear (3) is open. Install fuel pump idler gear (3). Put plate (2) in position with the finished side facing toward fuel pump idler gear (3). Apply Tooling (B) on bolts (1). Install bolts (1) that hold fuel pump idler gear (3) in position.

**Note:** Remove excess Tooling (B) on plate (2). Excess Tooling (B) on plate (2) may flow into the gear bearings. This condition can affect lubrication. Bearing life can also be affected.

**End By:** Install the automatic timing advance unit. Refer to Disassembly and Assembly, "Automatic Timing Advance - Install".

[Previous Screen](#)

Product: WHEEL LOADER

Model: 930R WHEEL LOADER 57Z

Configuration: 930R WHEEL LOADER 57Z03017-03999 (MACHINE) POWERED BY 3304 ENGINE

## Disassembly and Assembly 3304B and 3306B Engines for Caterpillar Built Machines

Media Number -SEN5598-09

Publication Date -01/01/2013

Date Updated -25/01/2013

i02107163

## Housing (Front) - Remove

SMCS - 1151-011

## Removal Procedure

### Start By:

- A. Remove the water pump. Refer to Disassembly and Assembly, "Water Pump - Remove".
- B. Remove the crankshaft front seal. Refer to Disassembly and Assembly, "Crankshaft Front Seal - Remove".

---

### NOTICE

**Keep all parts clean from contaminants.**

**Contaminants may cause rapid wear and shortened component life.**

---

---

### NOTICE

**Care must be taken to ensure that fluids are contained during performance of inspection, maintenance, testing, adjusting and repair of the product. Be prepared to collect the fluid with suitable containers before opening any compartment or disassembling any component containing fluids.**

**Refer to Special Publication, NENG2500, "Caterpillar Tools and Shop Products Guide" for tools and supplies suitable to collect and contain fluids on Caterpillar products.**

**Dispose of all fluids according to local regulations and mandates.**

- 
1. Remove the bolts that hold the oil pan and the oil pan plate to the front housing. Loosen the remaining bolts that hold the oil pan in position. Put spacers between the cylinder block and the oil pan plate. This must be done in order to prevent damage to the gasket for the oil pan plate.

**Note:** If the gasket for the oil pan plate is damaged, the oil pan plate must be removed. Refer to Disassembly and Assembly, "Engine Oil Pan Plate - Remove and Install".

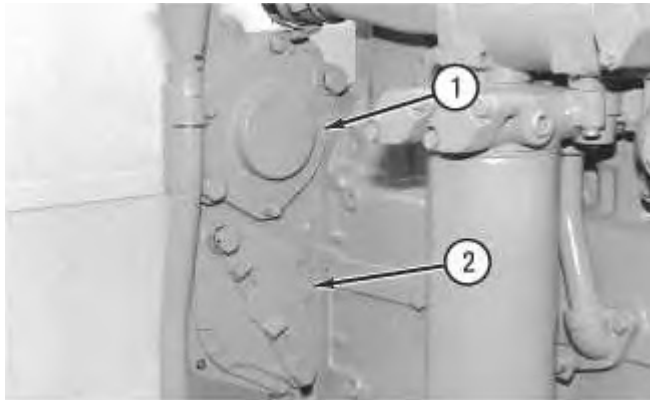

Illustration 1

g00512114

2. Remove covers (1) and (2) from the back of the front plate.

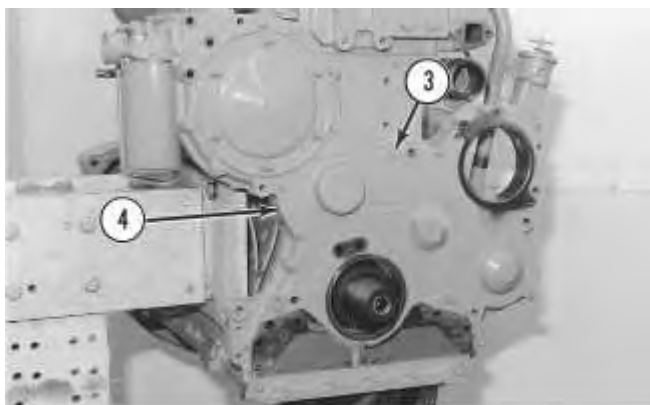

Illustration 2

g00512122

3. Remove all bolts (3) that hold front housing (4) in position on the engine. Remove front housing (4) and the gasket from the engine.

Previous Screen

Product: WHEEL LOADER

Model: 930R WHEEL LOADER 57Z

Configuration: 930R WHEEL LOADER 57Z03017-03999 (MACHINE) POWERED BY 3304 ENGINE

**Disassembly and Assembly  
3304B and 3306B Engines for Caterpillar Built Machines**

Media Number -SEN5598-09

Publication Date -01/01/2013

Date Updated -25/01/2013

i02107191

## Housing (Front) - Install

SMCS - 1151-012

### Installation Procedure

Table 1

Required Tools			
Tool	Part Number	Part Description	Qty
A	3S-6252	Sealant	1

---

**NOTICE**

**Keep all parts clean from contaminants.**

**Contaminants may cause rapid wear and shortened component life.**

---

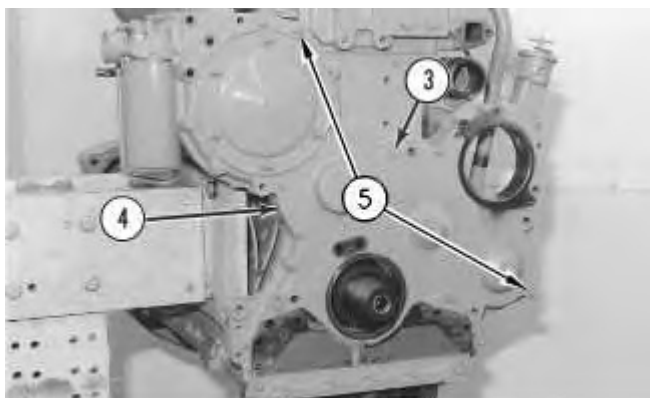

1. Put the gasket and front housing (4) in position on the engine. Install all bolts (3) that hold the front housing to the engine. Tighten bolts (5) to a torque of  $23 \pm 4 \text{ N}\cdot\text{m}$  ( $17 \pm 3 \text{ lb ft}$ ).

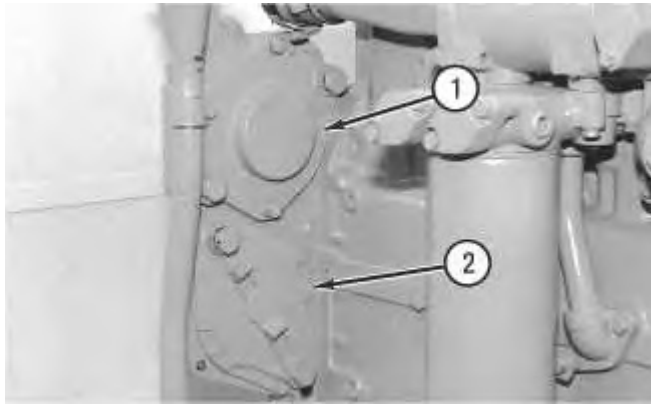

2. Put the gasket and cover (1) in position and install the bolts that fasten cover (1) to the front plate. Put the O-ring seal and cover (2) in position and install the bolts that fasten cover (2) to the front plate.
3. Trim the front housing gasket so the gasket is even with the bottom of the cylinder block.  
**Note:** If the oil pan plate was removed, install a new gasket and install the oil pan plate. Refer to Disassembly and Assembly, "Engine Oil Pan Plate - Remove and Install".
4. Apply Tooling (A) to the bottom surface of the front housing gasket. Remove the spacers that were installed between the cylinder block and the oil pan plate. Install the bolts that hold the oil pan and the oil pan plate to the front housing. Tighten the remaining bolts that hold the oil pan in position.

[Previous Screen](#)

Product: WHEEL LOADER

Model: 930R WHEEL LOADER 57Z

Configuration: 930R WHEEL LOADER 57Z03017-03999 (MACHINE) POWERED BY 3304 ENGINE

## Disassembly and Assembly 3304B and 3306B Engines for Caterpillar Built Machines

Media Number -SEN5598-09

Publication Date -01/01/2013

Date Updated -25/01/2013

i04880697

# Valve Mechanism Cover - Remove and Install

SMCS - 1107-010

## 3304B Removal Procedure

---

### NOTICE

**Keep all parts clean from contaminants.**

**Contaminants may cause rapid wear and shortened component life.**

---

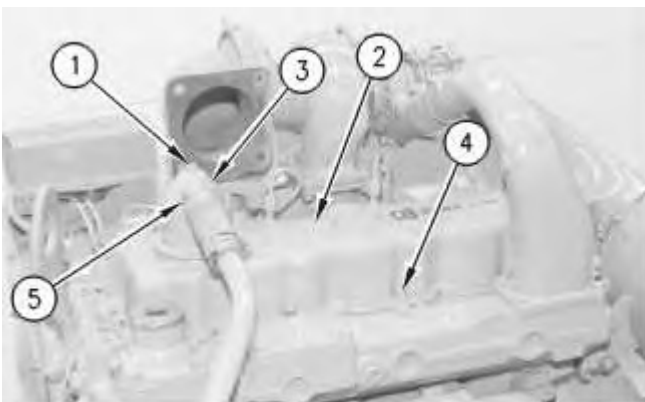

Illustration 1

g00590318

1. Loosen hose clamp (5) and remove the hose from breather cap (3) .
2. Remove bolt (1) and remove breather cap (3) .

3. Remove bolts (4) and the washers that hold valve mechanism cover (2) in position. Remove valve mechanism cover (2) and the gasket.

## 3306B Removal Procedure

---

### NOTICE

**Keep all parts clean from contaminants.**

**Contaminants may cause rapid wear and shortened component life.**

---

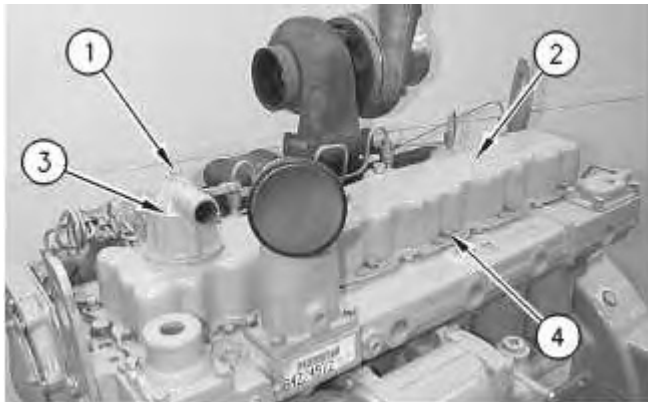

Illustration 2

g00513507

1. Remove bolt (1) and breather cap (3) from valve mechanism cover (2) . Remove the O-ring seal from breather cap (3) .
2. Remove bolts (4) and the washers that hold valve mechanism cover (2) in position. Remove valve mechanism cover (2) and the gasket.

## 3304B Installation Procedure

---

### NOTICE

**Keep all parts clean from contaminants.**

**Contaminants may cause rapid wear and shortened component life.**

---

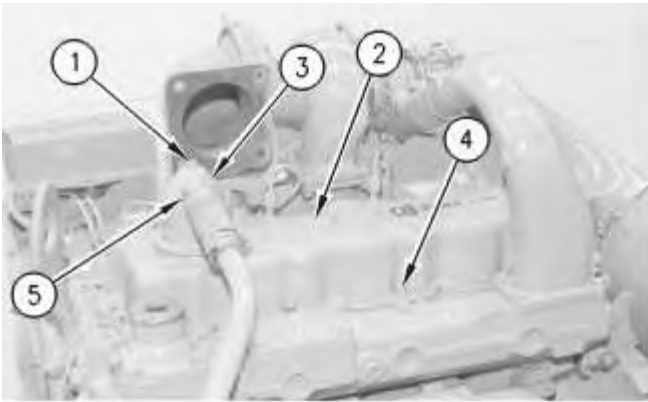

Illustration 3

g00590318

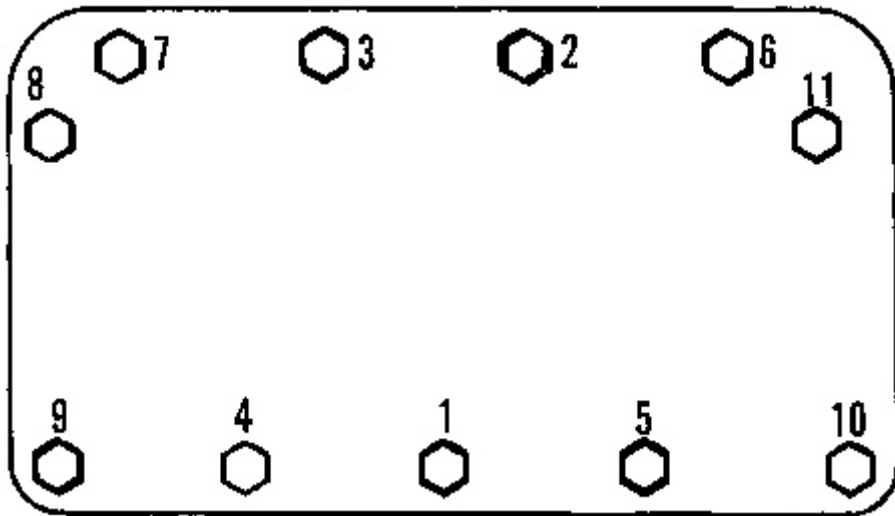

Illustration 4

g00590290

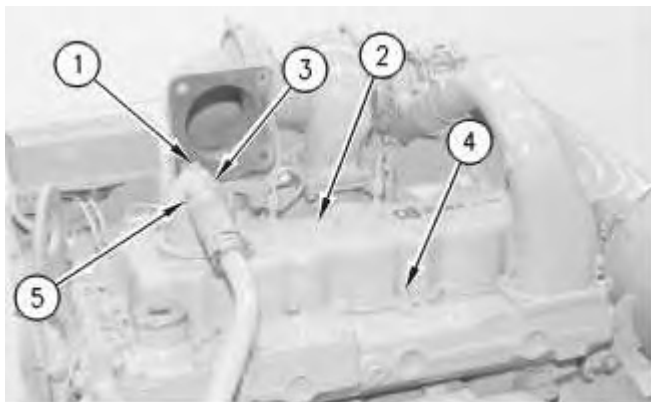

Illustration 5

g00590318

**Note:** Check the condition of the gasket. If the gasket is worn or damaged, use new parts for replacement.

1. Install a new gasket for valve mechanism cover (2) . Apply **5H-2471** Adhesive on the surfaces of the gasket and valve mechanism cover (2) . Place valve mechanism cover (2) in position on the cylinder head.
2. Install bolts (4) that hold valve mechanism cover (2) . Tighten the bolts in a numerical sequence to a torque of  $16 \pm 3$  N·m ( $12 \pm 2$  lb ft).
3. Install the hose on breather cap (3) and tighten hose clamp (5) .

## 3306B Installation Procedure

---

### NOTICE

**Keep all parts clean from contaminants.**

**Contaminants may cause rapid wear and shortened component life.**

---

**Note:** Check the condition of the gasket and O-ring seals. If the gasket or the O-ring seals are worn or damaged, use new parts for replacement.

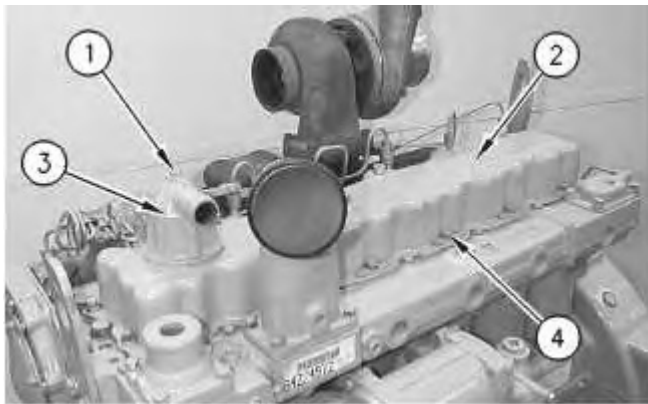
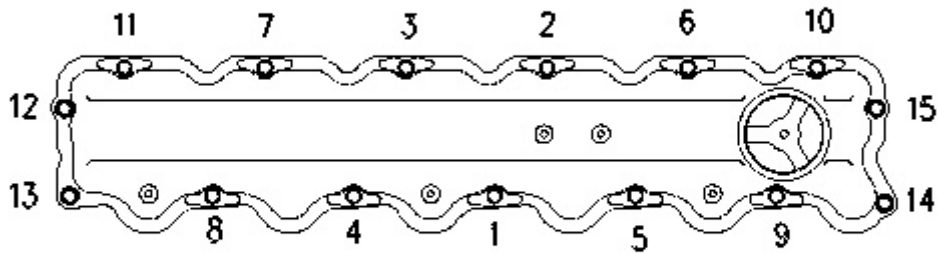

Illustration 6

g00513507

1. Install a new gasket for valve mechanism cover (2) . Put valve mechanism cover (2) in position on the cylinder head.
-



---

Illustration 7

g00450791

2. Install the washers and bolts (4) that hold valve mechanism cover (2) in position. Tighten the bolts in a numerical sequence to a torque of  $16 \pm 3 \text{ N}\cdot\text{m}$  ( $12 \pm 2 \text{ lb ft}$ ). Use the numerical sequence that is shown in illustration 7.
3. Put the O-ring seal and breather cap (3) in position. Install the washer and bolt (1). Tighten bolt (1) to a torque of  $14 \pm 3 \text{ N}\cdot\text{m}$  ( $10 \pm 2 \text{ lb ft}$ ).

[Previous Screen](#)

Product: WHEEL LOADER

Model: 930R WHEEL LOADER 57Z

Configuration: 930R WHEEL LOADER 57Z03017-03999 (MACHINE) POWERED BY 3304 ENGINE

## Disassembly and Assembly 3304B and 3306B Engines for Caterpillar Built Machines

Media Number -SEN5598-09

Publication Date -01/01/2013

Date Updated -25/01/2013

i00921540

# Compression Brake - Remove

SMCS - 1119-011

## Removal Procedure

### Start By:

- A. Remove the valve mechanism cover. Refer to Disassembly and Assembly, "Valve Mechanism Cover - Remove and Install".

---

### NOTICE

**Keep all parts clean from contaminants.**

**Contaminants may cause rapid wear and shortened component life.**

---

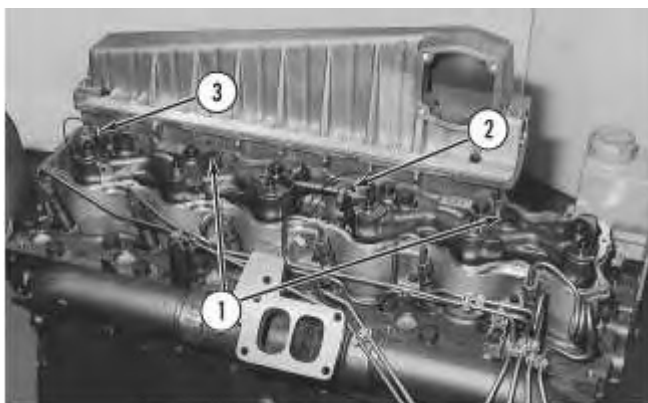

Illustration 1

g00471009

1. Remove four bolts (1). Disconnect wires (2) and (3) .

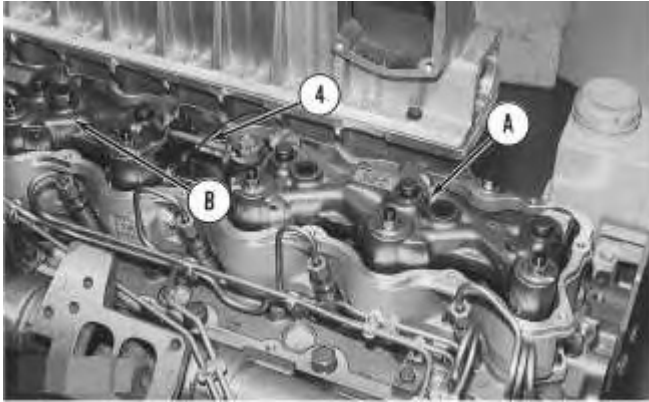

Illustration 2

g00471010

2. Remove Compression Brake (A) by lifting Compression Brake (A) with one hand. Remove Compression Brake (A) while you hold oil tube (4) in order to ensure that oil tube (4) does not come out of Compression Brake (B) .
3. Remove Compression Brake (B) .

[Previous Screen](#)

Product: WHEEL LOADER

Model: 930R WHEEL LOADER 57Z

Configuration: 930R WHEEL LOADER 57Z03017-03999 (MACHINE) POWERED BY 3304 ENGINE

## Disassembly and Assembly 3304B and 3306B Engines for Caterpillar Built Machines

Media Number -SEN5598-09

Publication Date -01/01/2013

Date Updated -25/01/2013

i00921740

# Compression Brake - Disassemble

SMCS - 1119-015

## Disassembly Procedure

### Start By:

- A. Remove the Compression Brake. Refer to Disassembly and Assembly, "Compression Brake - Remove".

---

### NOTICE

**Keep all parts clean from contaminants.**

**Contaminants may cause rapid wear and shortened component life.**

---

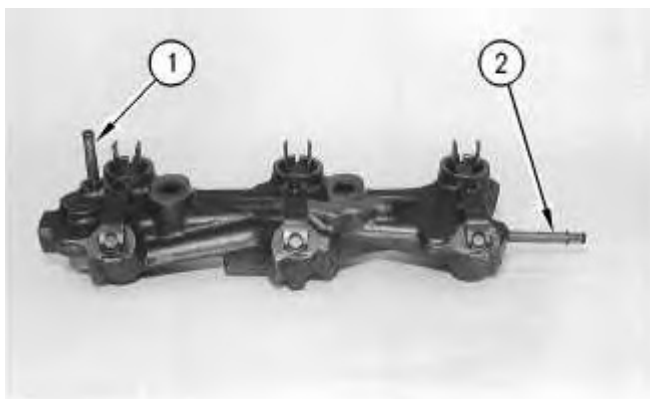

Illustration 1

g00471083



**Suggest:**

**If the above button click is invalid.**

**Please download this document**

**first, and then click the above link**

**to download the complete manual.**

**Thank you so much for reading**



**Suggest:**

**If the above button click is invalid.**

**Please download this document**

**first, and then click the above link**

**to download the complete manual.**

**Thank you so much for reading**

1. Remove oil tubes (1) and (2). Remove the O-ring seals.

**Note:** If the O-ring seals are worn or damaged, use new parts for replacement.

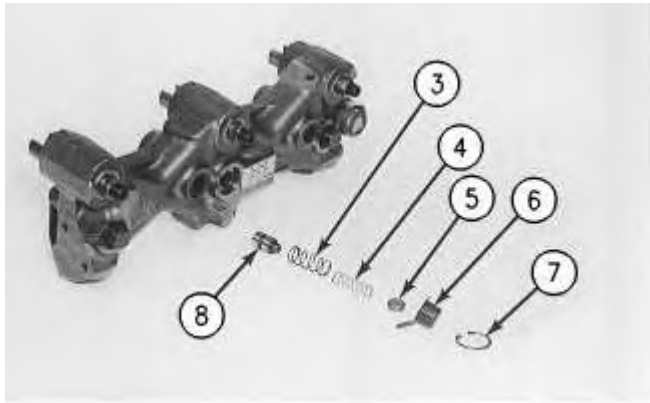

Illustration 2

g00471084

2. Remove snap ring (7), cup (6), spacer (5), springs (4) and (3) and piston (8) .

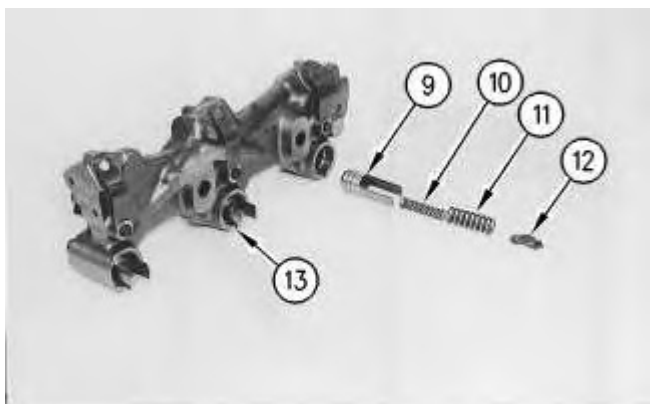

Illustration 3

g00471085

3. Remove three retaining rings (13). Remove clip (12), springs (11) and (10) and piston (9) from three locations on the Compression Brake.
-

**<https://www.ebooklibonline.com>**

Hello dear friend!

Thank you very much for reading.

Enter the link into your browser.

The full manual is available for immediate download.

**<https://www.ebooklibonline.com>**