



# Service Repair Manual

## **Models**

385C FS Excavator

---

[Previous Screen](#)

Product: EXCAVATOR

Model: 385C FS EXCAVATOR T2F

Configuration: 385C FS Excavator T2F00001-UP (MACHINE) POWERED BY C18 Engine

## Disassembly and Assembly C15 and C18 Engines for Caterpillar Built Machines

Media Number -REN8261-28

Publication Date -01/08/2015

Date Updated -28/08/2018

i02905633

# Valve Actuator (Variable) - Install

SMCS - 1105-012

## Installation Procedure

---

### NOTICE

**Keep all parts clean from contaminants.**

**Contaminants may cause rapid wear and shortened component life.**

---

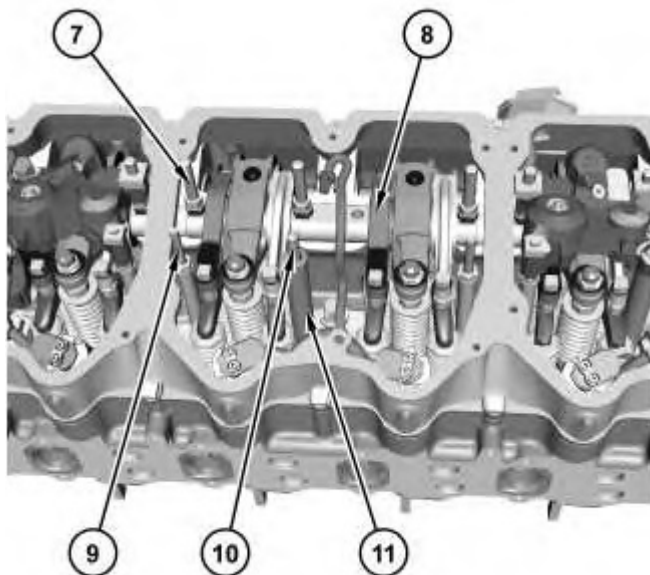
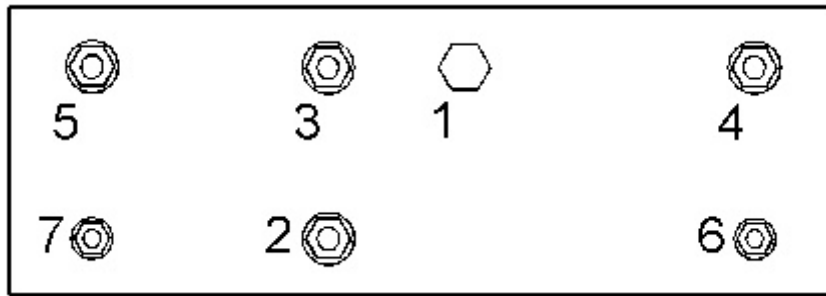

Illustration 1

g01446248



---

Illustration 2

g01446408

1. Install two studs (9) at Location 6 and Location 7. Tighten studs (9) to a torque of  $47 \pm 9 \text{ N}\cdot\text{m}$  ( $35 \pm 7 \text{ lb ft}$ ).
2. Install stud (10) at Location 2. Tighten stud (10) to a torque of  $65 \pm 10 \text{ N}\cdot\text{m}$  ( $48 \pm 7 \text{ lb ft}$ ). Install support (11).
3. Position rocker arm assembly (8). Install three studs (7) at Location 3, Location 4, and Location 5. Tighten studs (7) to a torque of  $50 \pm 5 \text{ N}\cdot\text{m}$  ( $37 \pm 4 \text{ lb ft}$ ). Turn studs (7) for an additional  $45 \pm 5$  degrees.

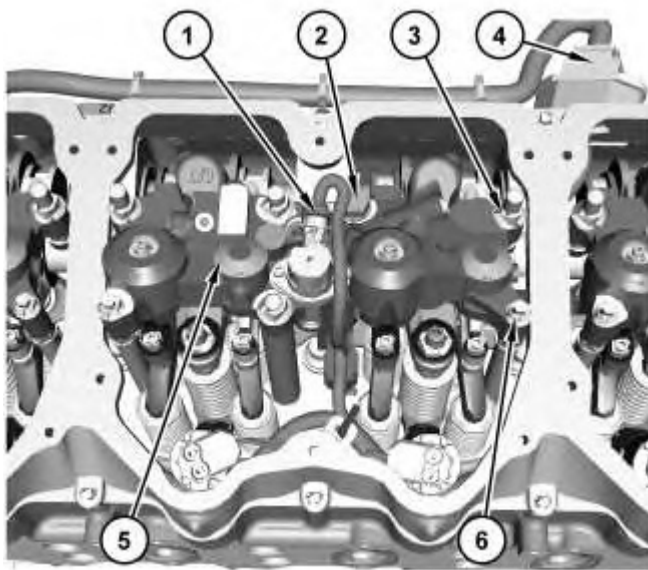

---

Illustration 3

g01446246

4. Install variable valve actuator (5).
  5. Install bolt (2). Install four nuts (3). Install two nuts (6). Refer to the tightening sequence.
  6. Tighten bolt (2) to a torque of  $105 \pm 20 \text{ N}\cdot\text{m}$  ( $77 \pm 15 \text{ lb ft}$ ). Tighten nuts (3) to a torque of  $105 \pm 20 \text{ N}\cdot\text{m}$  ( $77 \pm 15 \text{ lb ft}$ ). Tighten nuts (6) to a torque of  $47 \pm 9 \text{ N}\cdot\text{m}$  ( $35 \pm 7 \text{ lb ft}$ ). Tighten the nuts and the bolt in a numerical sequence.
  7. Connect harness assembly (4). Connect harness assembly (1) to variable valve actuator (5).
-

**<https://www.ebooklibonline.com>**

Hello dear friend!

Thank you very much for reading.

Enter the link into your browser.

The full manual is available for immediate download.

**<https://www.ebooklibonline.com>**

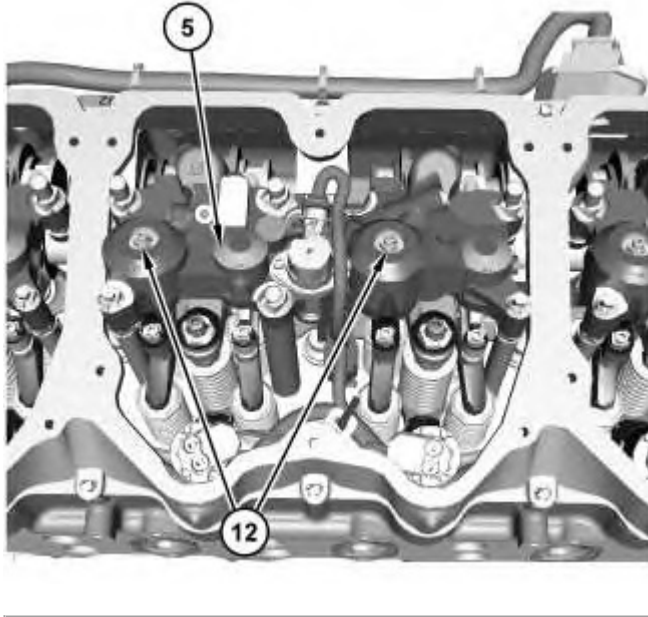

Illustration 4

g01446444

8. First adjust the lash on the exhaust and then adjust the compression brake on variable valve actuator (5). Refer to Testing and Adjusting, "Compression Brake Lash - Adjust" for more information on adjusting the lash for the compression brake. Tighten jam nut (12) to a torque of  $15 \pm 3 \text{ N}\cdot\text{m}$  ( $11 \pm 2 \text{ lb ft}$ ).

**End By:**

- a. Install the valve mechanism cover. Refer to Disassembly and Assembly, "Valve Mechanism Cover - Remove and Install".

Previous Screen

Product: EXCAVATOR

Model: 385C FS EXCAVATOR T2F

Configuration: 385C FS Excavator T2F00001-UP (MACHINE) POWERED BY C18 Engine

**Disassembly and Assembly  
C15 and C18 Engines for Caterpillar Built Machines**

Media Number -REN8261-28

Publication Date -01/08/2015

Date Updated -28/08/2018

i02906282

## Rocker Arm and Shaft - Remove

SMCS - 1102-011

### Removal Procedure

Table 1

Required Tools			
Tool	Part Number	Part Description	Qty
A	124-2946	Lifting Bracket	1

**Start By:**

- A. Remove the valve mechanism cover. Refer to Disassembly and Assembly, "Valve Mechanism Cover - Remove and Install".
- B. Remove the variable valve actuator, if necessary. Refer to Disassembly and Assembly, "Valve Actuator (Variable) - Remove".

---

**NOTICE**

**Keep all parts clean from contaminants.**

**Contaminants may cause rapid wear and shortened component life.**

---

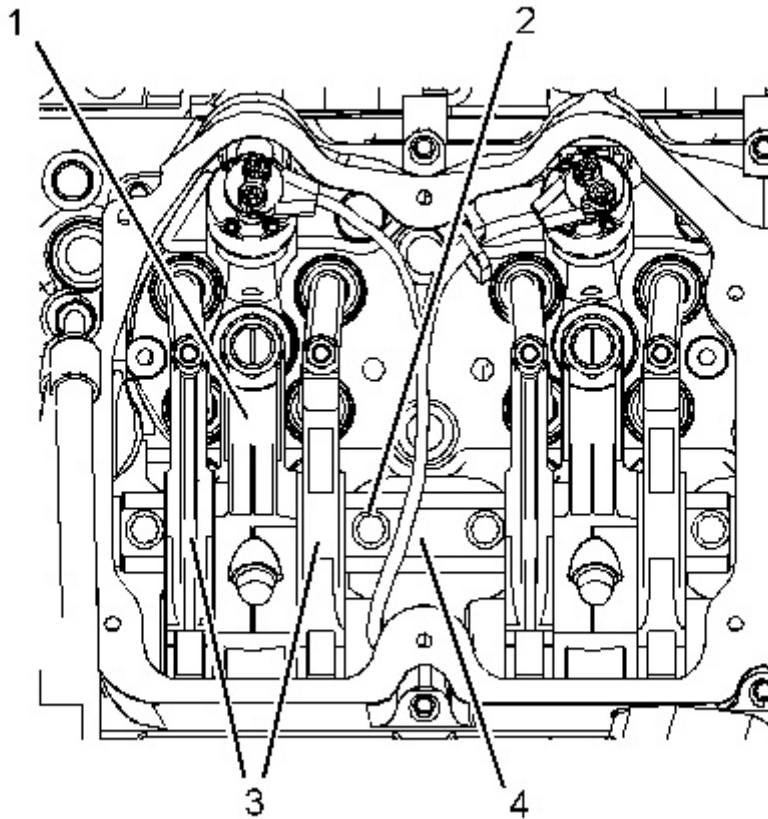

---

Illustration 1

g01117306

1. Remove bolts (2) .
2. Use Tooling (A) to remove rocker arm shaft assembly (4) , valve rocker arms (3) , and electronic unit injector rocker arms (1) as a unit.

[Previous Screen](#)

Product: EXCAVATOR

Model: 385C FS EXCAVATOR T2F

Configuration: 385C FS Excavator T2F00001-UP (MACHINE) POWERED BY C18 Engine

## Disassembly and Assembly C15 and C18 Engines for Caterpillar Built Machines

Media Number -REN8261-28

Publication Date -01/08/2015

Date Updated -28/08/2018

i04997049

# Rocker Arm - Disassemble

SMCS - 1123-015

## Disassembly Procedure

### Start By:

- a. Remove the rocker arms and the rocker shaft. Refer to Disassembly and Assembly, "Rocker Arm and Shaft - Remove".

---

### NOTICE

**Keep all parts clean from contaminants.**

**Contaminants may cause rapid wear and shortened component life.**

---

---

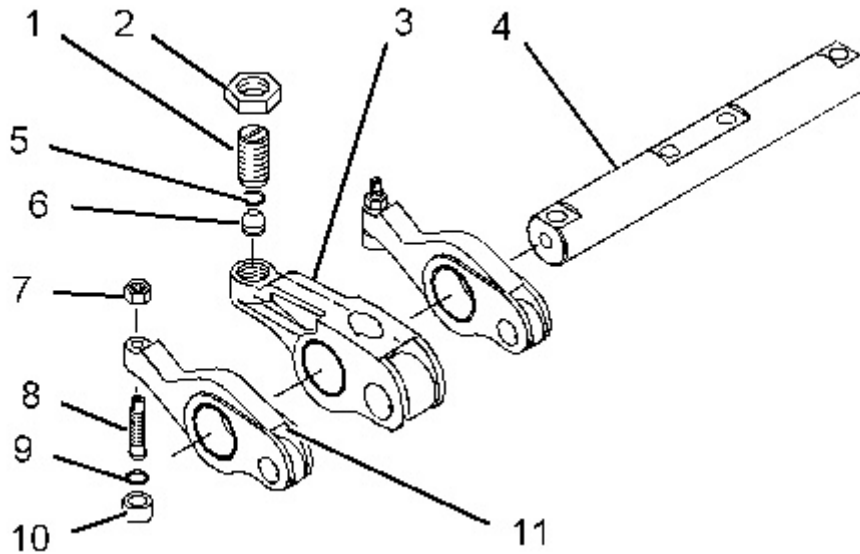

Illustration 1

g01047557

1. Remove valve rocker arms (11) and electronic unit injector rocker arm (3) from rocker shaft assembly (4).
2. Remove jam nut (7) from adjustment screw (8).
3. Remove adjustment screw (8) from valve rocker arms (11).
4. Remove button (10) from adjustment screw (8). Remove O-ring seal (9) from the adjustment screw.
5. Remove jam nut (2) from unit injector adjustment screw (1).
6. Remove unit injector adjustment screw (1) from electronic unit injector rocker arm (3).
7. Remove button (6) from unit injector adjustment screw (1). Remove O-ring seal (5) from the unit injector adjustment screw.

Previous Screen

Product: EXCAVATOR

Model: 385C FS EXCAVATOR T2F

Configuration: 385C FS Excavator T2F00001-UP (MACHINE) POWERED BY C18 Engine

**Disassembly and Assembly  
C15 and C18 Engines for Caterpillar Built Machines**

Media Number -REN8261-28

Publication Date -01/08/2015

Date Updated -28/08/2018

i04998150

**Rocker Arm - Assemble**

SMCS - 1123-016

**Assembly Procedure**

---

**NOTICE**

**Keep all parts clean from contaminants.**

**Contaminants may cause rapid wear and shortened component life.**

---

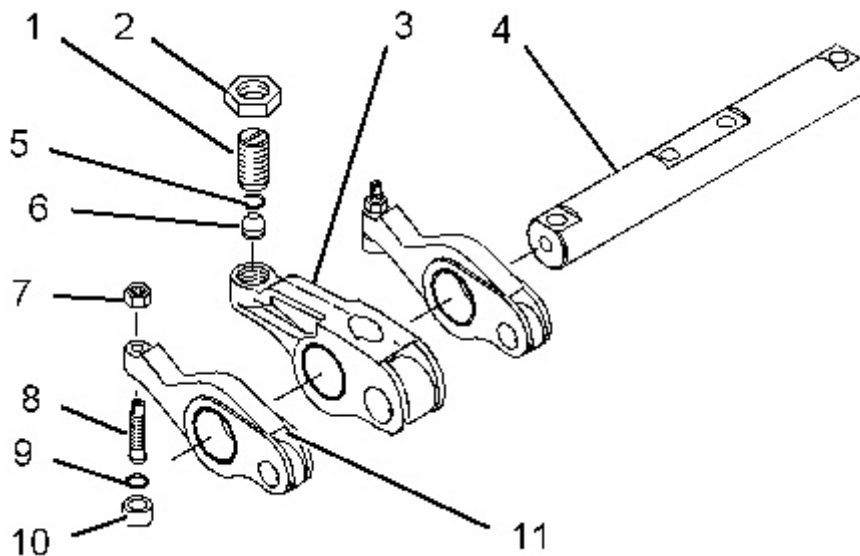

**Note:** Do not reuse the O-ring seal on the adjustment screw if the button is removed from the adjustment screw.

1. Install O-ring seal (9) in button (10).
2. Use a soft hammer to seat button (10) on adjustment screw (8).
3. Install adjustment screw (8) in valve rocker arms (11). Install jam nut (7) on the adjustment screw.
4. Install O-ring seal (5) in button (6).
5. Use a soft hammer to seat button (6) on unit injector adjustment screw (1).
6. Install unit injector adjustment screw (1) in electronic unit injector rocker arm (3). Install jam nut (2) on the unit injector adjustment screw.
7. Lubricate rocker shaft assembly (4) with clean engine oil.
8. Install valve rocker arms (11) and electronic unit injector rocker arm (3) on rocker shaft assembly (4).

**End By:**

- a. Install the rocker arms and the rocker shaft. Refer to Disassembly and Assembly, "Rocker Arm and Shaft - Install".

Previous Screen

Product: EXCAVATOR

Model: 385C FS EXCAVATOR T2F

Configuration: 385C FS Excavator T2F00001-UP (MACHINE) POWERED BY C18 Engine

**Disassembly and Assembly  
C15 and C18 Engines for Caterpillar Built Machines**

Media Number -REN8261-28

Publication Date -01/08/2015

Date Updated -28/08/2018

i07394739

## Rocker Arm and Shaft - Install

SMCS - 1102-012

### Installation Procedure

Table 1

Required Tools			
Tool	Part Number	Part Description	Qty
A	124-2946	Lifting Bracket	1

---

**NOTICE**

**Keep all parts clean from contaminants.**

**Contaminants may cause rapid wear and shortened component life.**

---

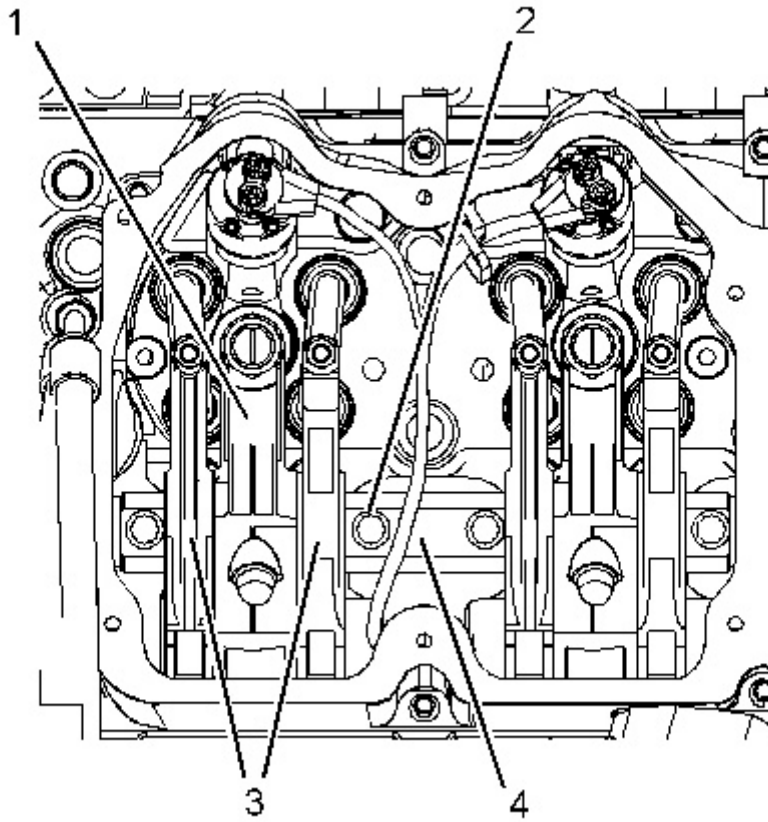

Illustration 1

g01117306

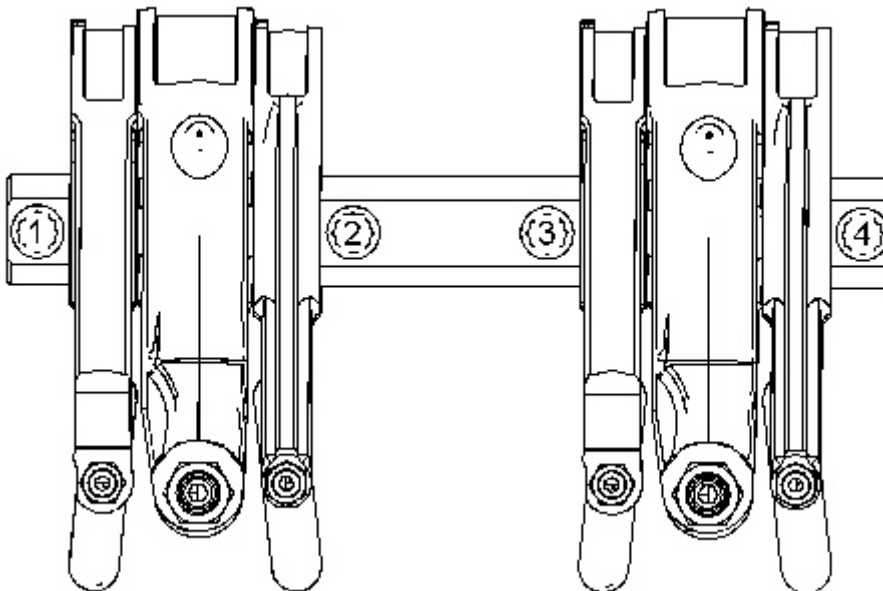

Illustration 2

g01325993

1. Position rocker arm shaft assembly (4), valve rocker arms (3), and electronic unit injector rocker arms (1) as a unit with Tooling (A) on the cylinder head.

**Note:** Apply clean engine oil to the underside of the bolt heads prior to installation.

2. Install bolts (2) and tighten to a torque of  $55 \pm 5$  N·m ( $41 \pm 4$  lb ft). Tighten bolts (2) again to a torque of  $55 \pm 5$  N·m ( $41 \pm 4$  lb ft). Turn bolts (2) for an additional  $60 \pm 5$  degrees. Tighten the bolts in the following sequence: 2, 3, 1, 4.
3. Adjust the electronic unit injectors. Refer to Testing and Adjusting, "Electronic Unit Injector - Adjust".
4. Adjust the engine valve lash. Refer to Testing and Adjusting, "Engine Valve Lash-Inspect/Adjust".

**End By:**

- a. Install the variable valve actuator, if necessary. Refer to Disassembly and Assembly, "Valve Actuator (Variable) - Install".
- b. Install the valve mechanism cover. Refer to Disassembly and Assembly, "Valve Mechanism Cover - Remove and Install".

[Previous Screen](#)

Product: EXCAVATOR

Model: 385C FS EXCAVATOR T2F

Configuration: 385C FS Excavator T2F00001-UP (MACHINE) POWERED BY C18 Engine

## Disassembly and Assembly C15 and C18 Engines for Caterpillar Built Machines

Media Number -REN8261-28

Publication Date -01/08/2015

Date Updated -28/08/2018

i02211115

# Cylinder Head - Remove

SMCS - 1100-011

## Removal Procedure

### Start By:

- a. Remove the camshaft gear. Refer to Disassembly and Assembly, "Camshaft Gear - Remove and Install".
- b. Remove the electronic unit injectors. Refer to Disassembly and Assembly, "Electronic Unit Injector - Remove".
- c. Remove the valve mechanism cover base. Refer to Disassembly and Assembly, "Valve Mechanism Cover Base - Remove and Install".
- d. Remove the turbochargers. Refer to Disassembly and Assembly, "Turbocharger - Remove".

---

### NOTICE

**Care must be taken to ensure that fluids are contained during performance of inspection, maintenance, testing, adjusting, and repair of the product. Be prepared to collect the fluid with suitable containers before opening any compartment or disassembling any component containing fluids.**

**Refer to Special Publication, NENG2500, "Dealer Service Tool Catalog" for tools and supplies suitable to collect and contain fluids on Cat products.**

**Dispose of all fluids according to local regulations and mandates.**

---

---

## NOTICE

**Keep all parts clean from contaminants.**

**Contaminants may cause rapid wear and shortened component life.**

---

---

## NOTICE

**Do not turn the crankshaft or the camshaft while the camshaft gear is removed. If the front gear group is not correctly timed during installation, interference can occur between the pistons and the valves, resulting in damage to the engine.**

---

1. Drain the cooling system. Refer to Operation and Maintenance Manual, "Cooling System Coolant - Change".
- 

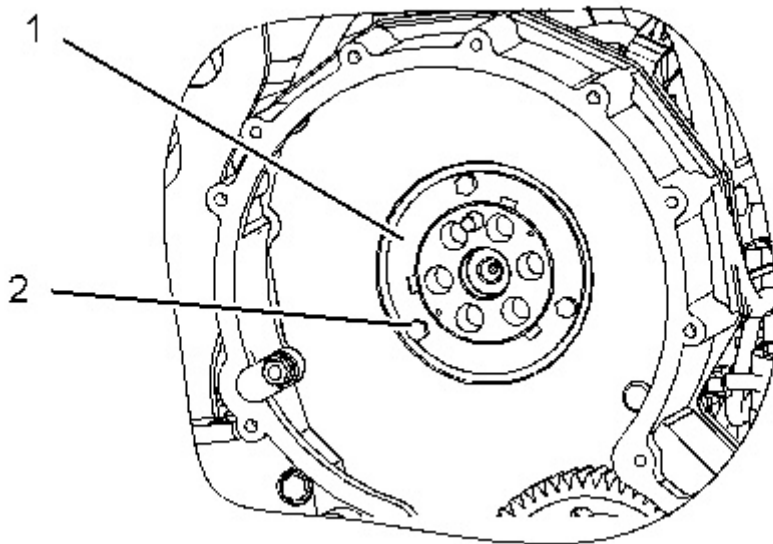

---

Illustration 1

g01056681

2. Remove bolts (2) and thrust plate (1).
-

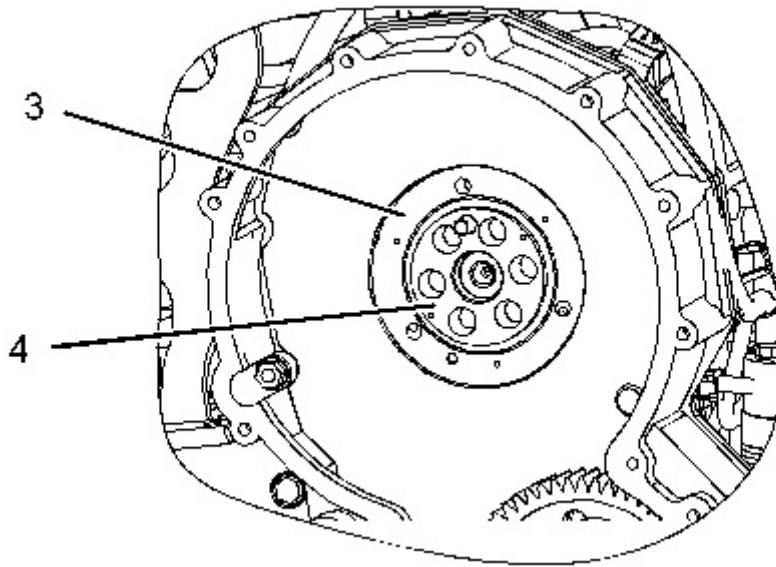

---

Illustration 2

g01116390

3. Remove sealing plate (3) and adapter assembly (4).
- 

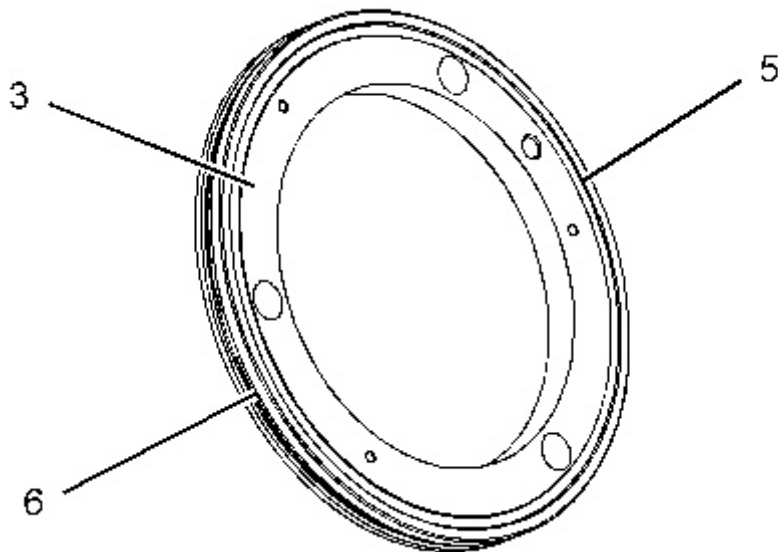

---

Illustration 3

g01056684

4. Remove O-ring seal (5) and O-ring seal (6) from sealing plate (3).
-

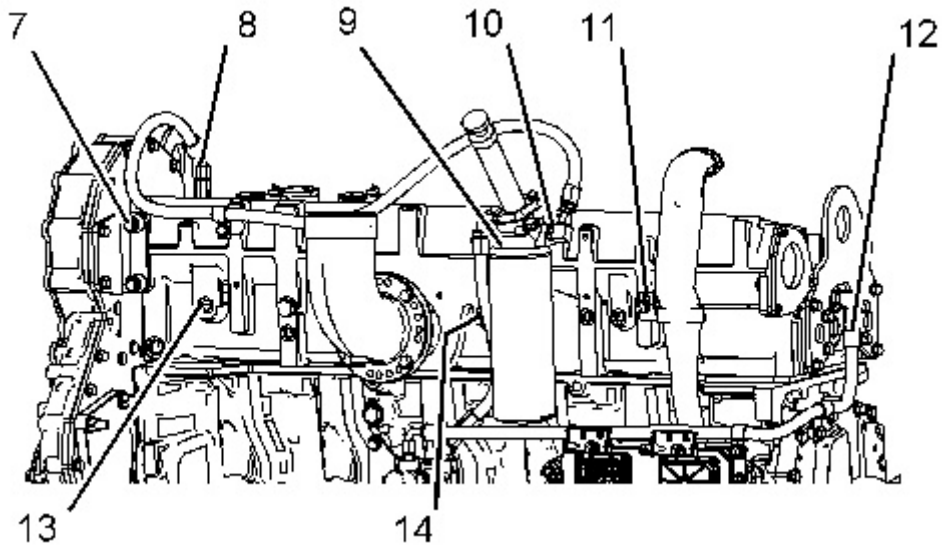

---

Illustration 4

g01117768

5. Disconnect hose assembly (8).
  6. Disconnect hose assembly (12).
  7. Remove bolts (10). Position fuel filter base (9) out of the way.
  8. Remove bolt (11) and the breather tube from the cylinder head.
  9. Remove bolts (7) and remove the bracket from the cylinder head.
  10. Disconnect boost pressure sensor (13).
  11. Disconnect inlet air temperature sensor (14).
-

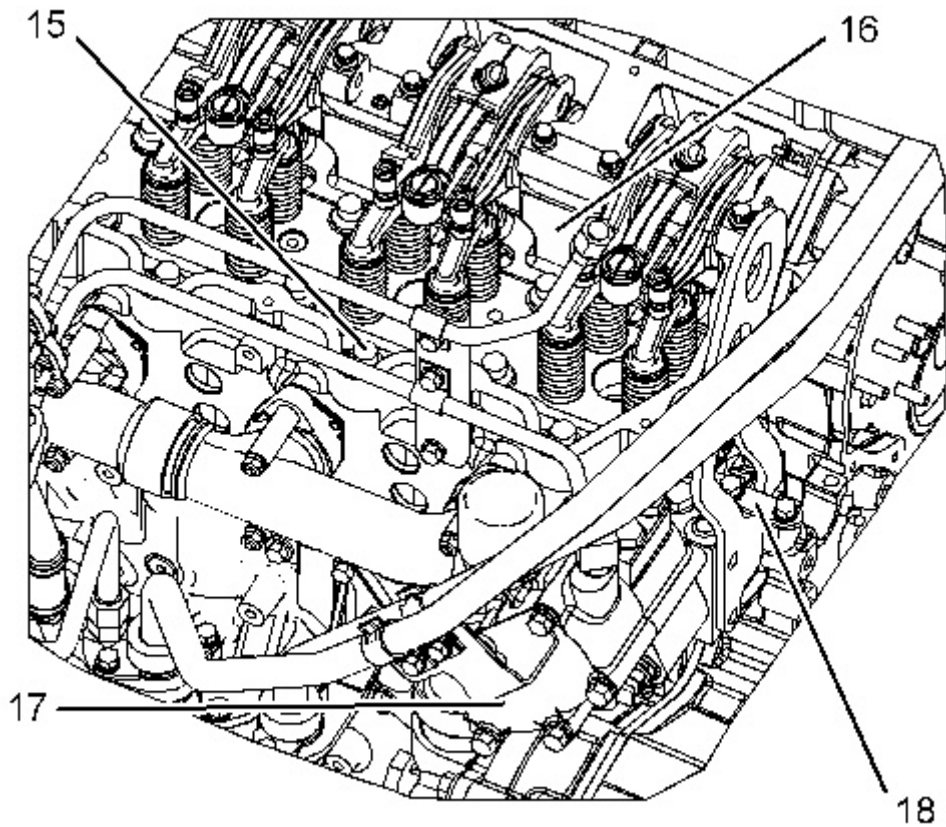

---

Illustration 5

g01116398

12. Remove water temperature regulator housing (17).
  13. Remove strap (18).
  14. Attach a suitable lifting device to cylinder head (16). The weight of the cylinder head is approximately 235 kg (518 lb).
  15. Remove cylinder head bolts (15).
  16. Carefully remove cylinder head (16).
-

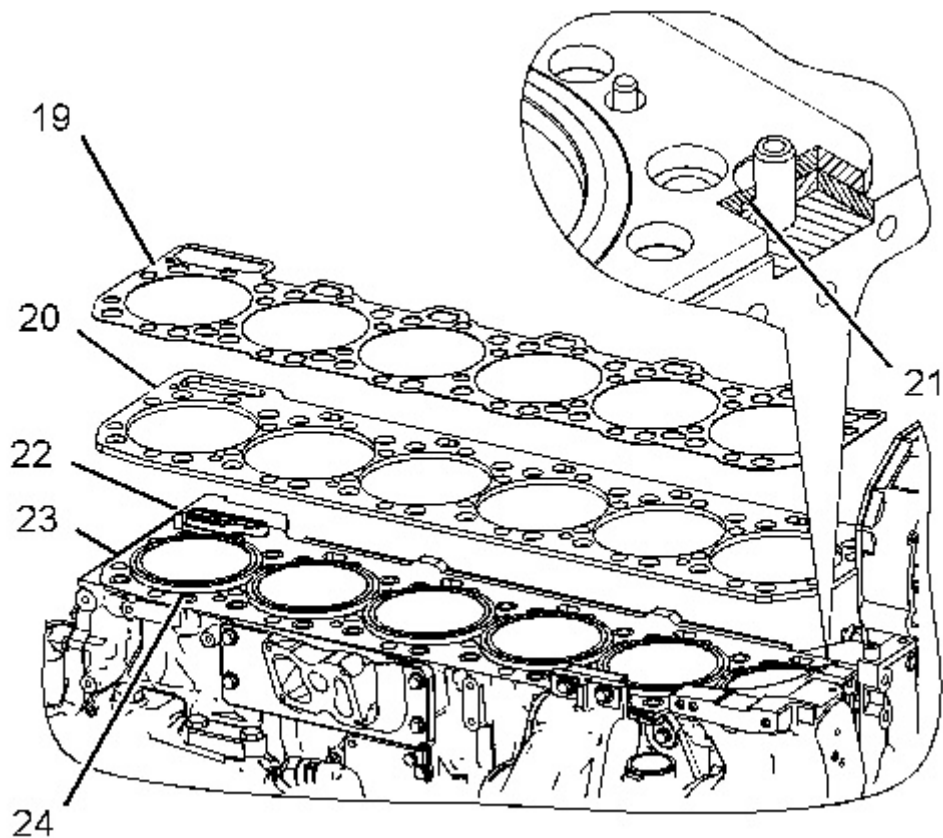

---

Illustration 6

g01117797

17. Remove cylinder head gasket (19).
18. Remove spacer plate (20).
19. Remove seals (24) and seal (22).
20. Remove spacer plate gasket (23).
21. Remove O-ring seal (21) from the dowel in the cylinder block.

Previous Screen

Product: EXCAVATOR

Model: 385C FS EXCAVATOR T2F

Configuration: 385C FS Excavator T2F00001-UP (MACHINE) POWERED BY C18 Engine

**Disassembly and Assembly  
C15 and C18 Engines for Caterpillar Built Machines**

Media Number -REN8261-28

Publication Date -01/08/2015

Date Updated -28/08/2018

i04410295

## Cylinder Head - Install

SMCS - 1100-012

### Installation Procedure

Table 1

Required Tools			
Tool	Part Number	Part Description	Qty
A	6V-4876	Lubricant	1
B	8T-2998	Lubricant	1
C	9S-3263	Thread Lock Compound	1

---

**NOTICE**

**Keep all parts clean from contaminants.**

**Contaminants may cause rapid wear and shortened component life.**

---

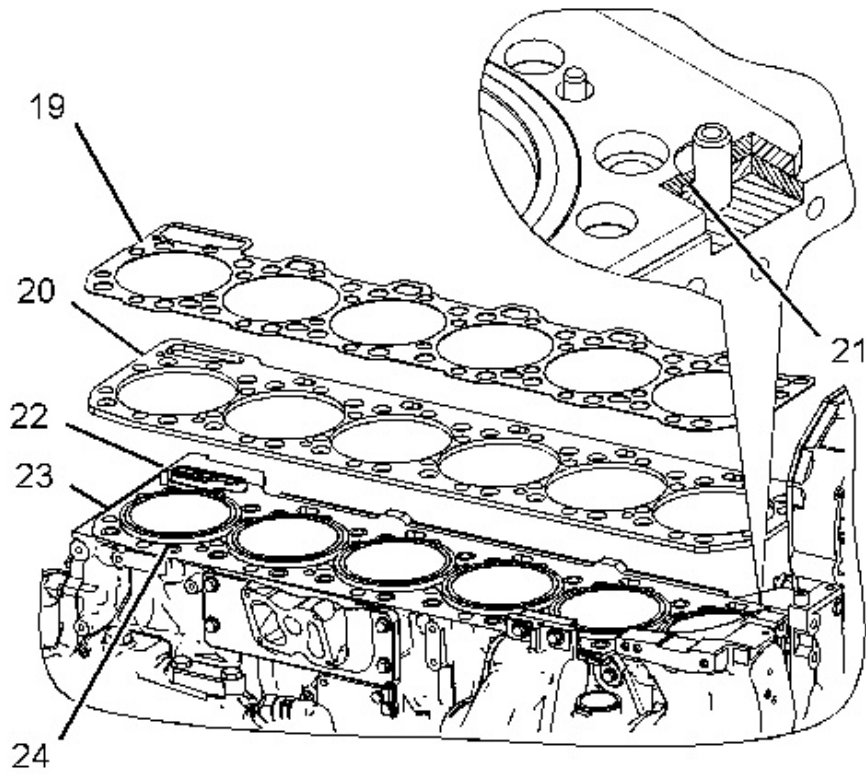

---

Illustration 1

g01117797

1. Install O-ring seal (21) on the dowel in the cylinder block.
  2. Install spacer plate gasket (23) on the cylinder block.
  3. Install seals (24) and seal (22) .
  4. Install spacer plate (20) .
  5. Install cylinder head gasket (19) on the spacer plate.
-

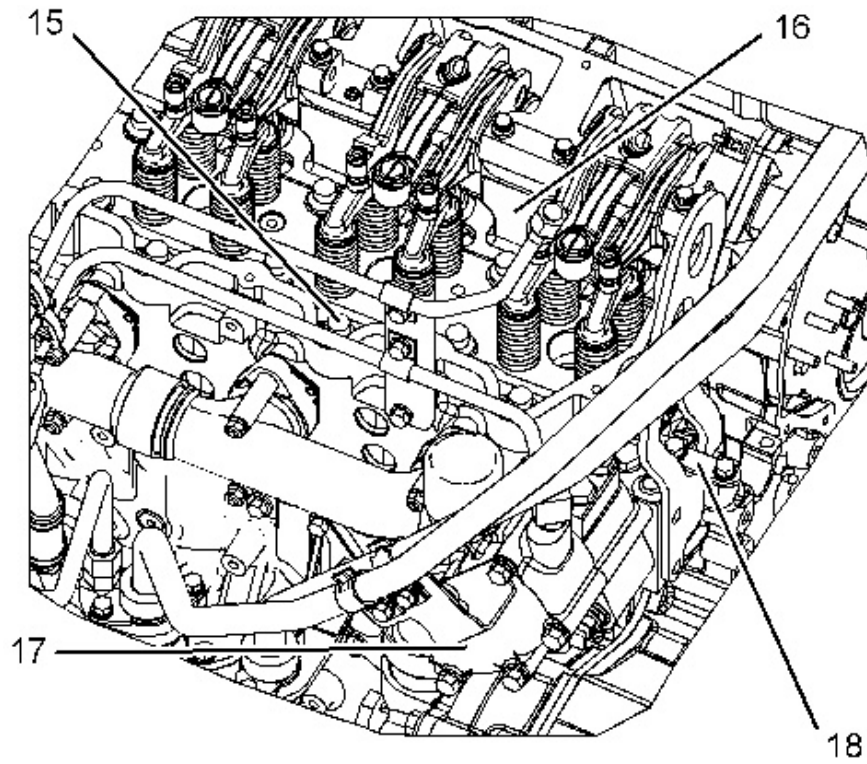
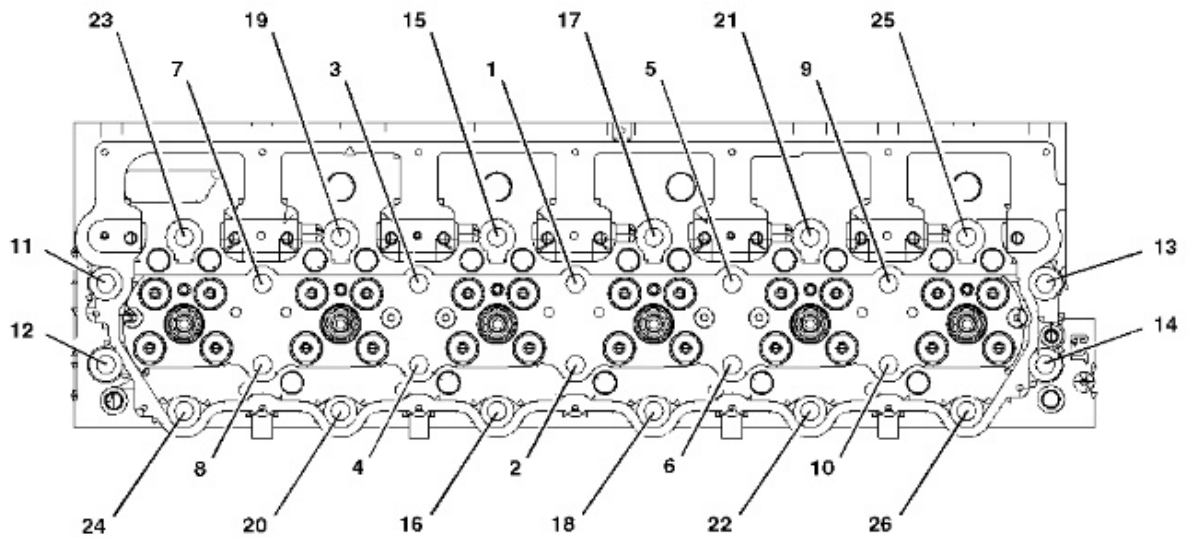

Illustration 2

g01116398

6. Attach a suitable lifting device to cylinder head (16) . The weight of the cylinder head is approximately 235 kg (518 lb).
7. Carefully install cylinder head (16) on the dowel pins on the cylinder block.



**Note:** The following bolts are 216 mm (8.5 inch) long: 11, 12, 13, 14, 16, 18, 20, 22, 24 and 26. The rest of the bolts are 194 mm (7.6 inch) long.

8. Apply Tooling (A) to the bolt threads and both sides of the washers for cylinder head bolts (15) . Install and tighten the bolts using the following sequence:
  - a. In a numerical sequence, tighten bolts 1 through 26 to a torque of  $270 \pm 15$  N·m ( $200 \pm 11$  lb ft).
  - b. In a numerical sequence, tighten bolts 1 through 26 to a torque of  $450 \pm 15$  N·m ( $330 \pm 11$  lb ft).
  - c. In a numerical sequence, again tighten bolts 1 through 26 to a torque of  $450 \pm 15$  N·m ( $330 \pm 11$  lb ft).
9. Install strap (18) .
10. Install water temperature regulator housing (17) .

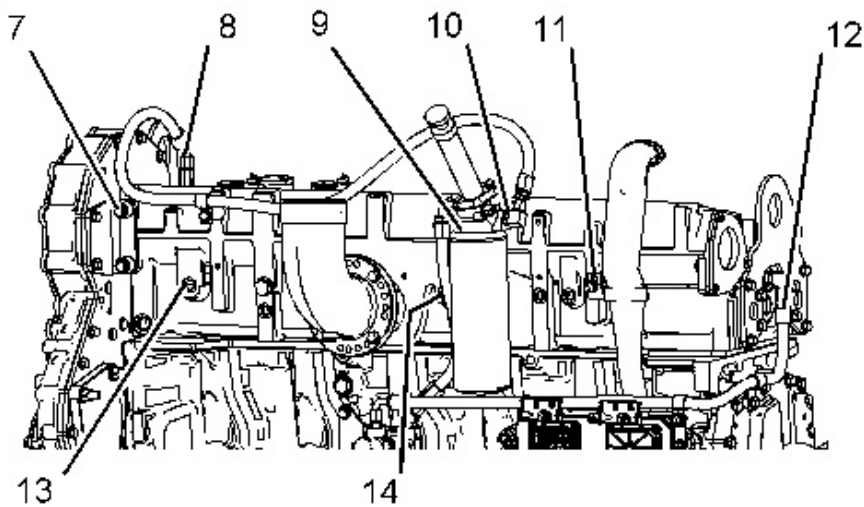

Illustration 4

g01117768

11. Connect inlet air temperature sensor (14) .
12. Connect boost pressure sensor (13) .
13. Position the bracket on the cylinder head and install bolts (7) .
14. Position the breather tube on the cylinder head and install bolt (11) . Tighten the bolt to a torque of  $10 \pm 3$  N·m ( $89 \pm 27$  lb in).
15. Position fuel filter base (9) on the cylinder head and install bolts (10) .
16. Connect hose assembly (12) .
17. Connect hose assembly (8) .



**Suggest:**

**If the above button click is invalid.**

**Please download this document**

**first, and then click the above link**

**to download the complete manual.**

**Thank you so much for reading**

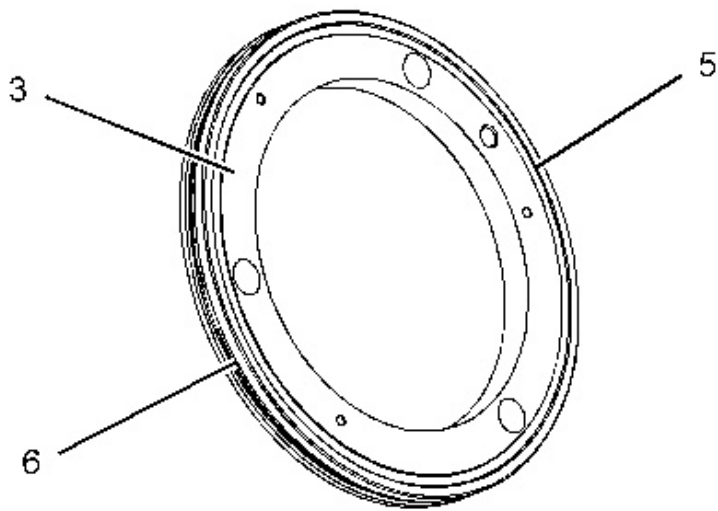

Illustration 5

g01056684

18. Install O-ring seal (5) and O-ring seal (6) on sealing plate (3) . Lubricate O-ring seal (6) with a 50/50 mixture of Tooling (B) and clean engine oil.

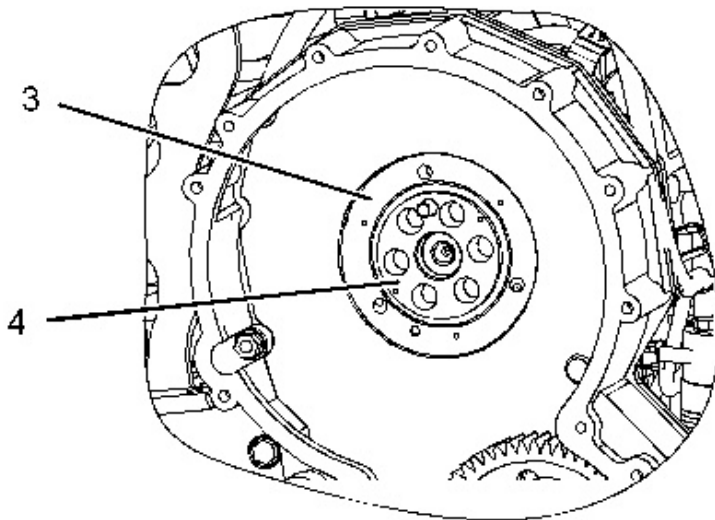

Illustration 6

g01116390

---

**<https://www.ebooklibonline.com>**

Hello dear friend!

Thank you very much for reading.

Enter the link into your browser.

The full manual is available for immediate download.

**<https://www.ebooklibonline.com>**