



Service Repair Manual

Models

352F, 352F-VG Excavator

[Previous Screen](#)

Product: EXCAVATOR

Model: 352F-VG EXCAVATOR YEG

Configuration: 352F Excavators YEG00001-UP (MACHINE) POWERED BY C13 Engine

Disassembly and Assembly 349F and 352F Excavators Machine Systems

Media Number -UENR0194-04

Publication Date -01/02/2018

Date Updated -21/02/2018

i07203491

Travel Motor - Disassemble

SMCS - 4351-015

Disassemble Procedure

Table 1

Required Tools			
Tool	Part Number	Part Description	Qty
A	1P-2420	Transmission Repair Stand	1
B	421-5662	Lifting Eye Assembly	1
C	154-6182	M12x1.75 mm Forcing Bolt	2
	6V-8149	M12x1.75 mm Nut	4
	5P-8245	M12 Hard Washer	4
D	-	M3x0.5 Threaded Rod	1
	3K-3068	3 mm Thrust Washer	1
	3C-6969	M3x0.5 Nut	2
E	8T-0276	M8x45mm Bolt	2
	9M-1974	M8 Hard Washer	2

Start By:

- a. Remove travel motor.

NOTICE

Care must be taken to ensure that fluids are contained during performance of inspection, maintenance, testing, adjusting, and repair of the product. Be prepared to collect the fluid with suitable containers before opening any compartment or disassembling any component containing fluids.

Refer to Special Publication, NENG2500, "Dealer Service Tool Catalog" for tools and supplies suitable to collect and contain fluids on Cat® products.

Dispose of all fluids according to local regulations and mandates.



Illustration 1

g06252257

1. Use Tooling (B) and a suitable lifting device to position travel motor (1) in a vertical position on Tooling (A). The weight of travel motor (1) is approximately 136 kg (300 lb). Use Tooling (C) to attach travel motor (1) to Tooling (A).
-

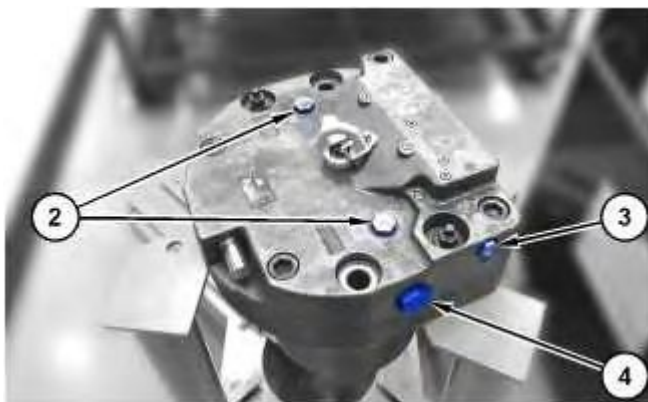

Illustration 2

g06252275

2. Remove plugs (2), plug (3), plug (4), and the O-ring seals.

<https://www.ebooklibonline.com>

Hello dear friend!

Thank you very much for reading.

Enter the link into your browser.

The full manual is available for immediate download.

<https://www.ebooklibonline.com>

WARNING

Personal injury can result from being struck by parts propelled by a released spring force.

Make sure to wear all necessary protective equipment.

Follow the recommended procedure and use all recommended tooling to release the spring force.

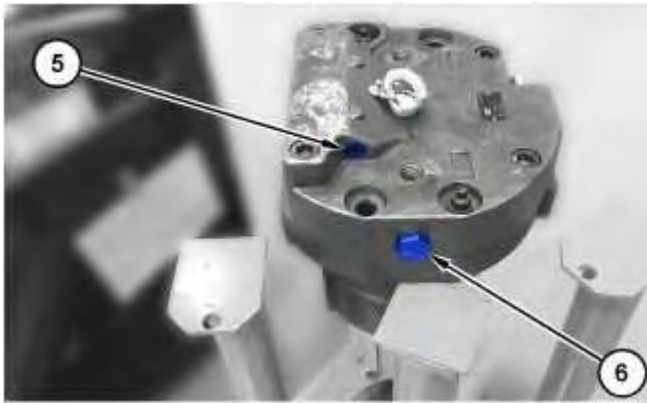

Illustration 3

g06252280

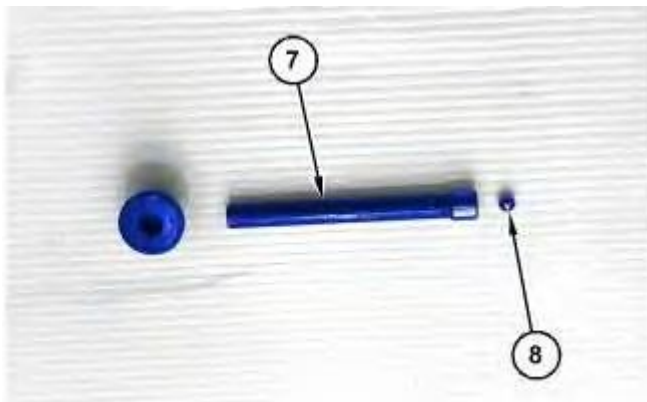

Illustration 4

g06252989

3. Remove plug (6) and the O-ring seal.
 4. Remove plug (5), stopper (7), and ball (8).
-

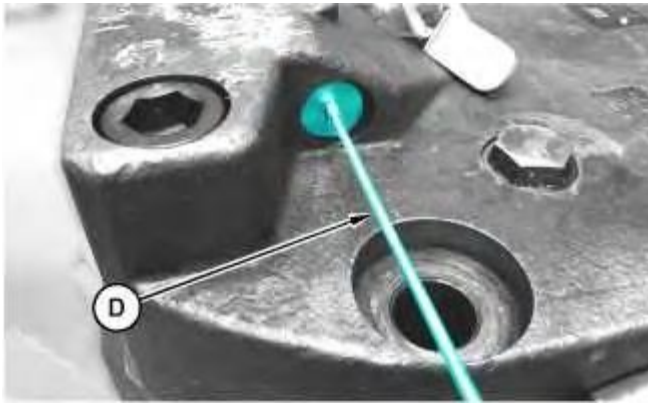

Illustration 5

g06255756

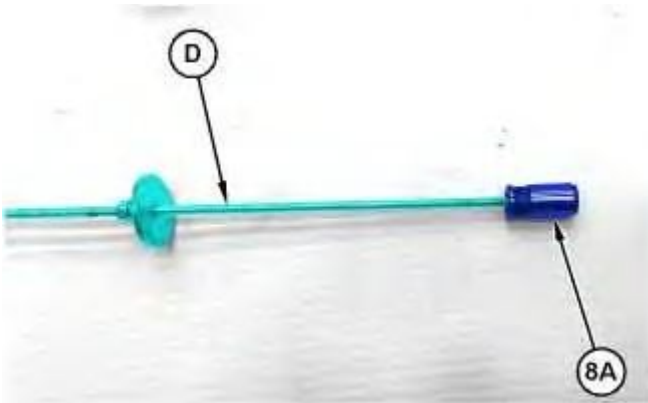

Illustration 6

g06255791

5. Use Tooling (D) and a suitable washer to extract seat (8A).

WARNING

Personal injury can result from being struck by parts propelled by a released spring force.

Make sure to wear all necessary protective equipment.

Follow the recommended procedure and use all recommended tooling to release the spring force.

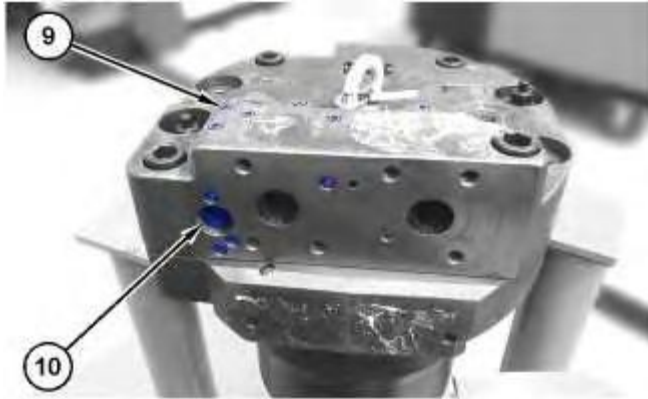

Illustration 7

g06252992

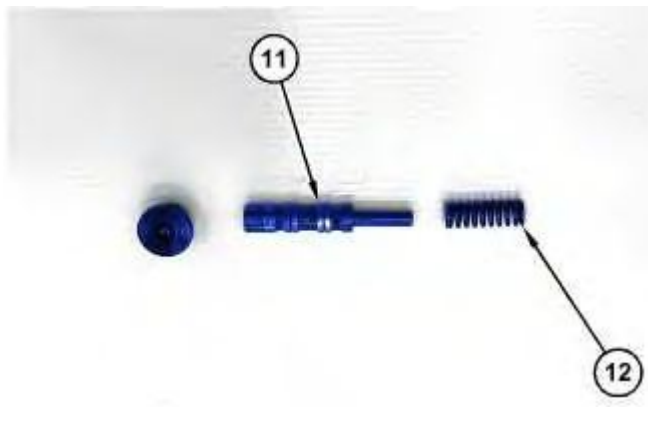

Illustration 8

g06252996

6. Remove plugs (9) and the O-ring seals.
7. Remove plug (10), spool (11), spring (12), and the O-ring seal.

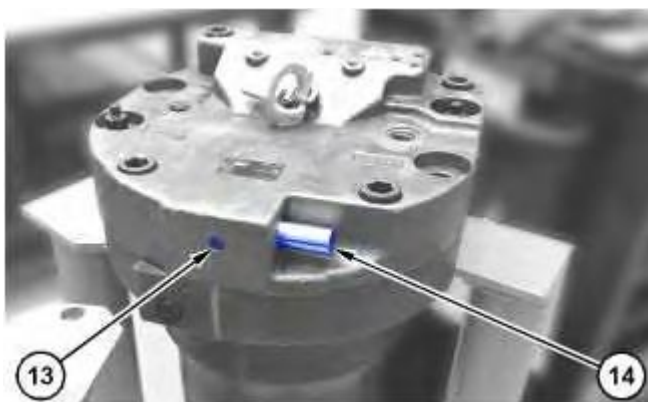

Illustration 9

g06253028

8. Remove plug (13), valve (14), and the O-ring seals.

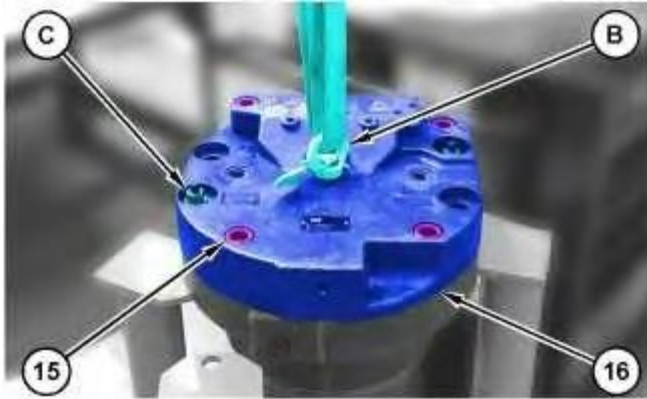

Illustration 10

g06253047

WARNING

Personal injury can result from being struck by parts propelled by a released spring force.

Make sure to wear all necessary protective equipment.

Follow the recommended procedure and use all recommended tooling to release the spring force.

9. Remove the top two nuts and washers from Tooling (C).
10. Remove bolts (15).
11. Use Tooling (B) and a suitable lifting device to remove motor head assembly (16). The weight of motor head assembly (16) is approximately 45 kg (100 lb). Remove motor head assembly (16).



Illustration 11

g06253060

12. Remove bearing (17) and O-ring seal (18).



Illustration 12

g06253330

13. Reinstall the washers and nuts from Tooling (C) that were removed in a previous Step.
14. Remove springs (19), O-ring seal (20), port plate (21), O-ring seal (22), plug (23), and the O-ring seal.

Note: Port plate (21) may still be adhered to the bottom of motor head assembly (16).



Illustration 13

g06253333

15. Remove orifice (24) and orifice (25).

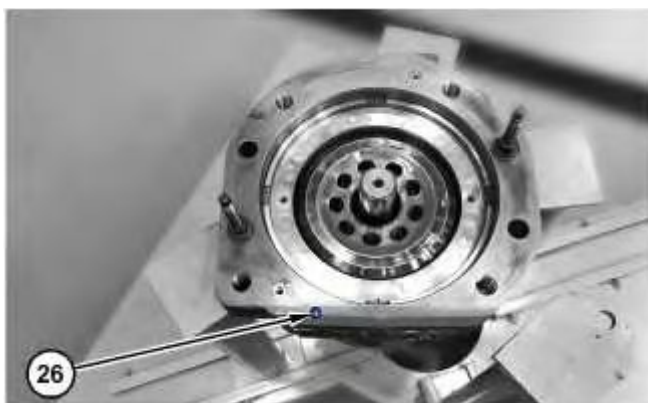

Illustration 14

g06253335

16. Remove plug (26).

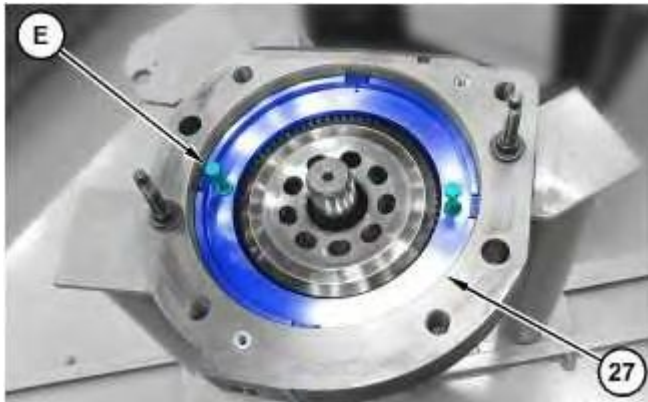

Illustration 15

g06253475

17. Use Tooling (E) and suitable prying devices to remove piston assembly (27).

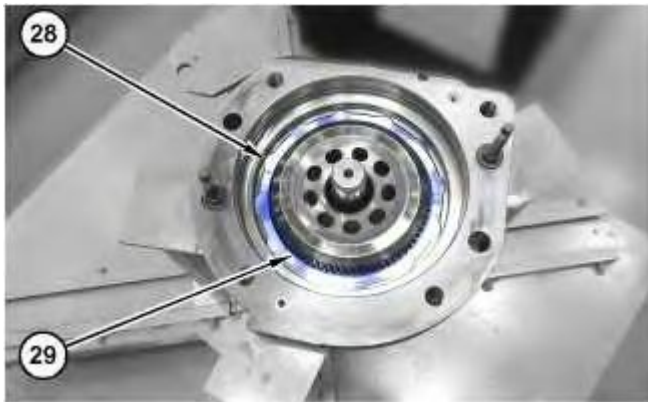

Illustration 16

g06253502

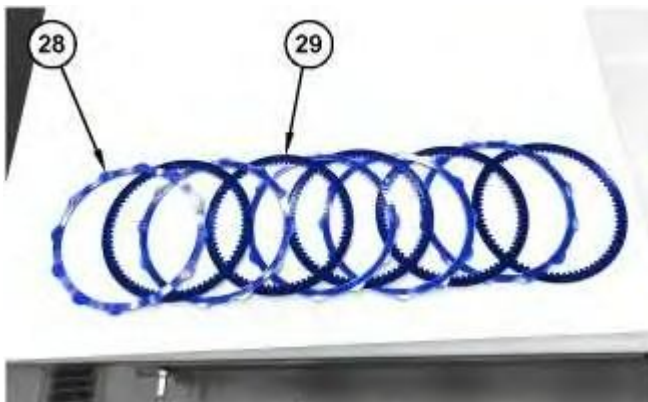

Illustration 17

g06253508

Typical example.

18. Remove separator plates (28) and friction plates (29). Note the alternating order of separator plates (28) and friction plates (29) for assembly purposes.



Illustration 18

g06253734

19. Remove barrel assembly (30).

Note: Do not allow the components of barrel assembly (30) to come apart while you remove barrel assembly (30). The components of barrel assembly (30) must be reinstalled into the original positions.



Illustration 19

g06253741

20. Remove piston assemblies (31) and retainer (32).

Note: Mark the component locations for assembly purposes before you disassemble the barrel assembly.



Personal injury can result from being struck by parts propelled by a released spring force.

Make sure to wear all necessary protective equipment.

Follow the recommended procedure and use all recommended tooling to release the spring force.



Illustration 20

g06253748

21. Remove guide (33).



Illustration 21

g06253755

22. Remove springs (34).



Illustration 22

g06254252

23. Put location marks on swashplate (35) for assembly purposes. Remove swashplate (35).

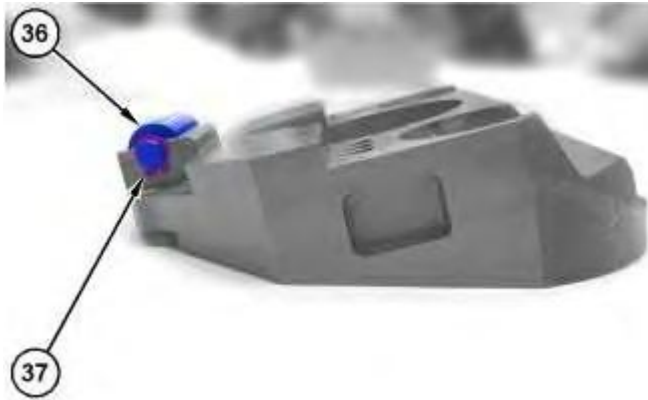

Illustration 23

g06254282

24. Remove snap ring (37) and roller (36).



Illustration 24

g06254306

25. Remove keys (38).

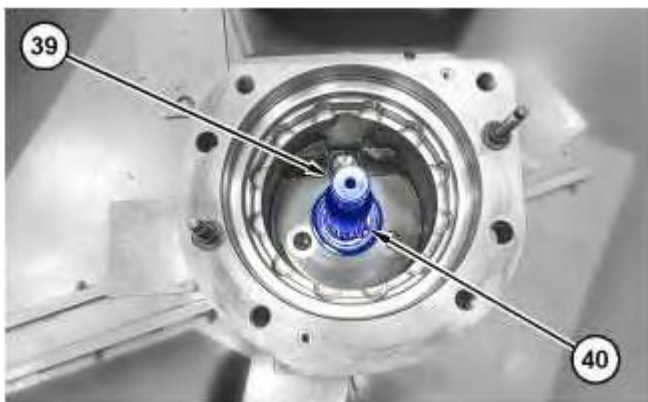

Illustration 25

g06254363

26. Remove snap ring (40).

27. Use a soft faced hammer to remove shaft assembly (39).

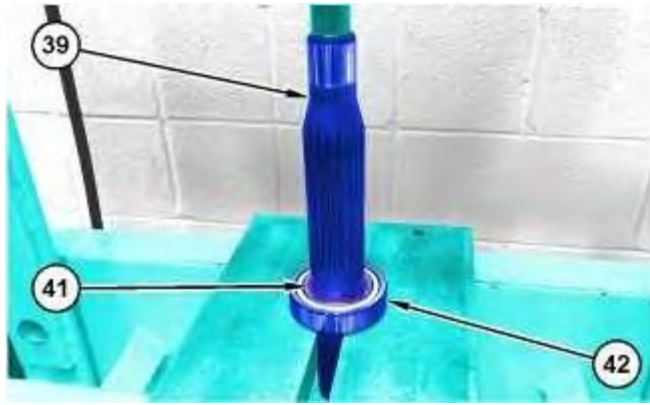

Illustration 26

g06254423

28. Remove snap ring (41).

29. Use a suitable press to remove bearing (42) from shaft assembly (39).



Illustration 27

g06254449

30. Remove O-ring seal (43) and O-ring seal (44).



Illustration 28

g06254465

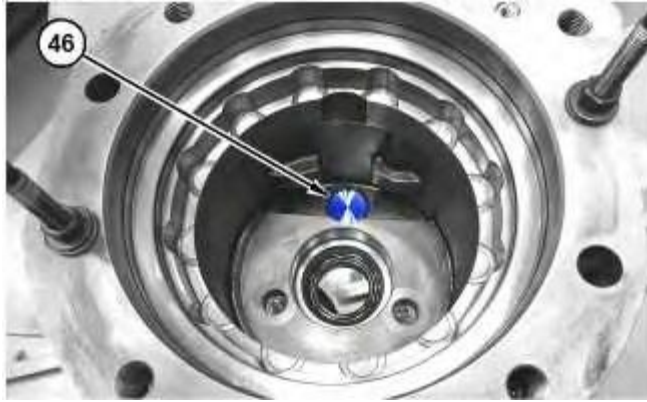

Illustration 29

g06254467

31. Remove plug (45) and use compressed air to remove piston (46).

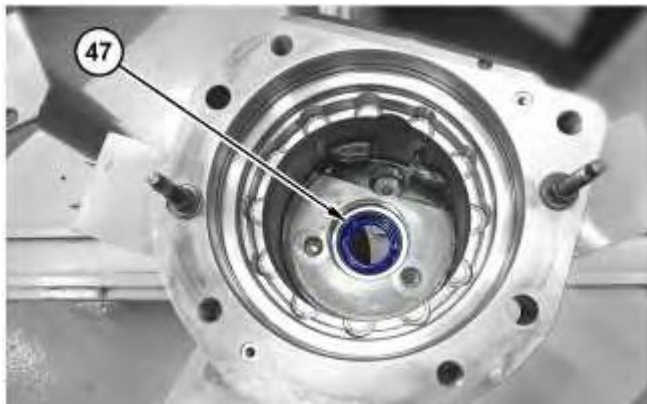

Illustration 30

g06254480

32. Remove lip seal (47).

Previous Screen

Product: EXCAVATOR

Model: 352F-VG EXCAVATOR YEG

Configuration: 352F Excavators YEG00001-UP (MACHINE) POWERED BY C13 Engine

Disassembly and Assembly
349F and 352F Excavators Machine Systems

Media Number -UENR0194-04

Publication Date -01/02/2018

Date Updated -21/02/2018

i06563923

Travel Motor - Assemble

SMCS - 4351-016

Specifications

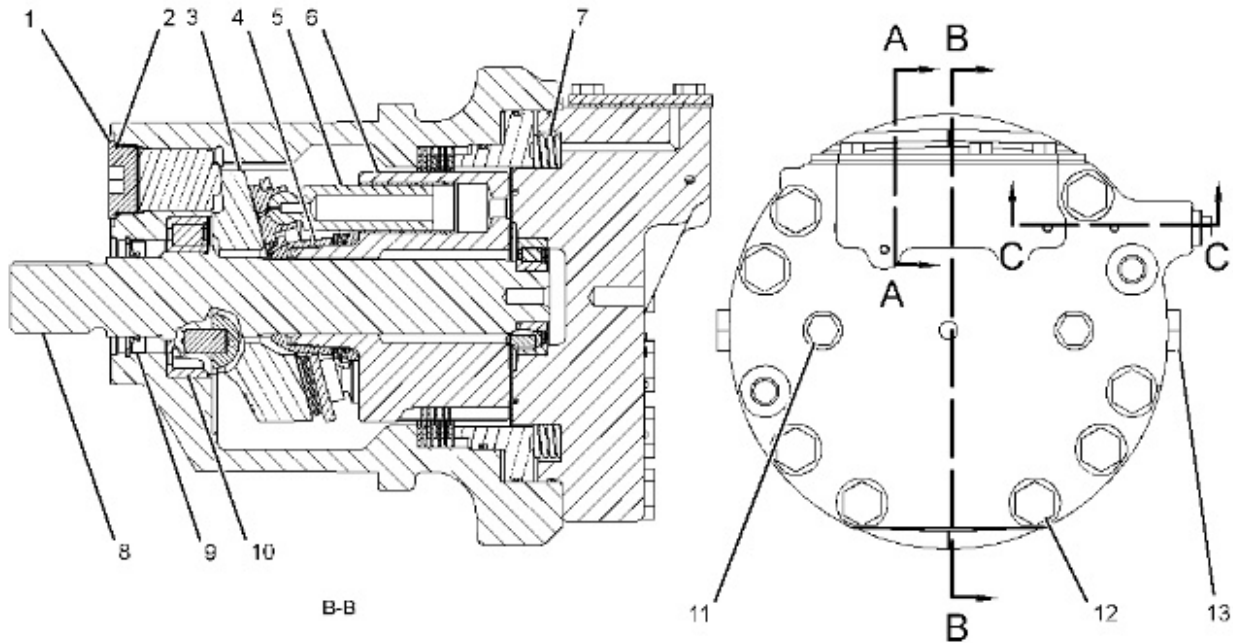

Illustration 1

g03845362

NOTICE

To prevent damage to the motor, the case must be filled with clean hydraulic oil at least to the fill port before operation.

Item	Qty	Part	Specification Description
14	2	1T-0936 Pipe Plug	Install in the orifice toward the head surface or below the head surface.
15	1	124-1554 Spring	Length under test force is 15 mm (0.6 inch). Test force is 15.0 ± 2.0 N (3.4 ± 0.4 lb). Free length after test is 16.15 mm (0.636 inch).
D	-	-	Depth from the head and interface of the port plate is 20.0 ± 0.2 mm (0.79 ± 0.01 inch).
16	1	195-4456 Orifice Plug	Torque to 7 ± 1 N·m (62 ± 9 lb in).

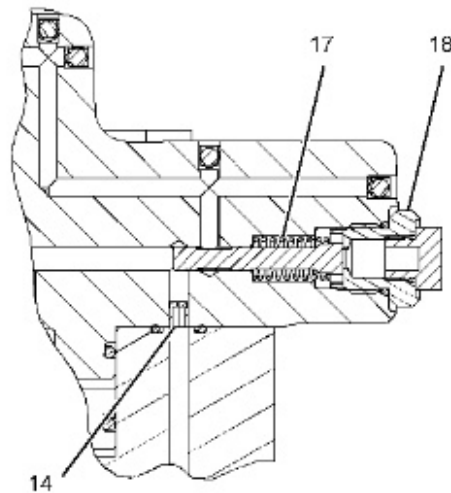

Illustration 3
Section C-C

g03845365

Table 3

Item	Qty	Part	Specification Description
17	1	230-5483 Spring	Length under test force is 25 mm (1.0 inch). Test force is 60.0 ± 8.0 N (13.5 ± 1.8 lb). Free length after test is 35 mm (1.4 inch).
18	1	087-4786 Adapter	Torque to 115 ± 10 N·m (85 ± 7 lb ft).

Assembly Procedure

Table 4

Required Tools			
Tool	Part Number	Part Description	Qty
A	138-7573	Link Bracket	1
D	3E-3879	Eyebolt	1

F	1U-6396	O-Ring Assembly Compound	1
G	-	Loctite 242	-
H	1P-0510	Driver Gp	1
J	6V-2055	Grease	1
K	128-5049	Guide Stud	2

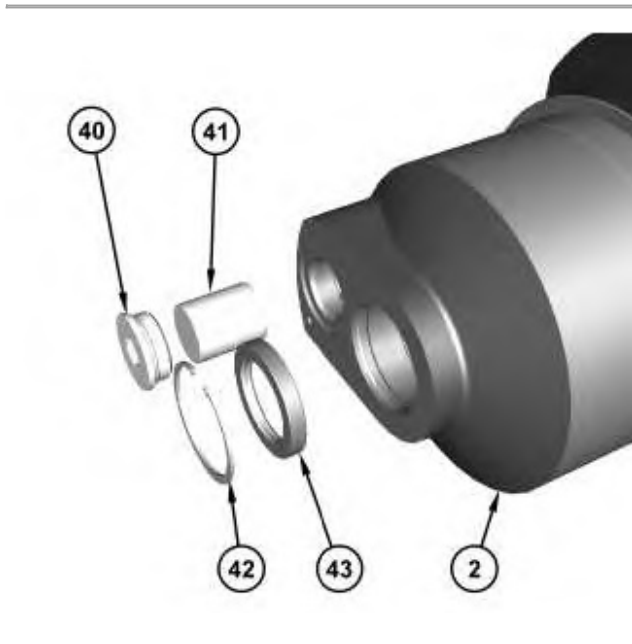

Illustration 4

g02421056

1. Lubricate actuator piston (41) with the oil that is being used. Install actuator piston (41) into housing (2). Apply Tooling (F) onto O-ring seal of plug (40). Install plug (40) into motor housing (2). Tighten plug (42) to a torque of 430 ± 40 N·m (315 ± 30 lb ft).
2. Apply Tooling (G) onto outside diameter of seal (43). Use Tooling (H) to install seal (43). Install retaining ring (42).

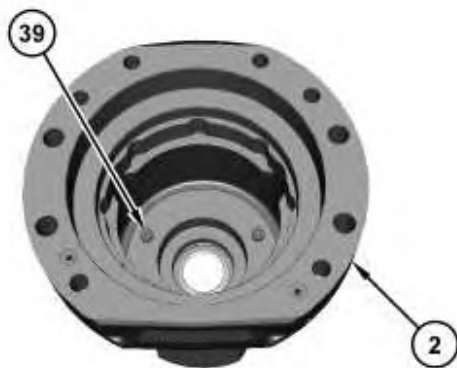

Illustration 5

g02421000



Illustration 6

g02420998

3. Install pins (39) and keys (38) into motor housing (2).

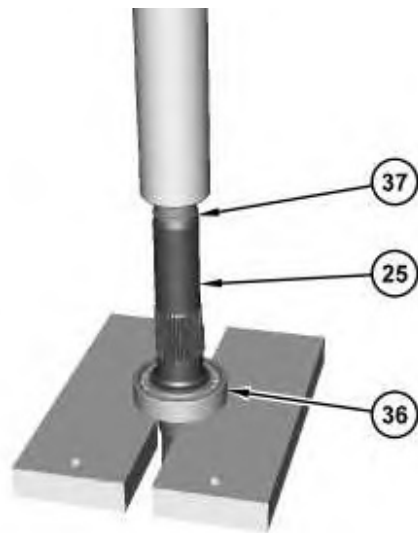

Illustration 7

g02421876

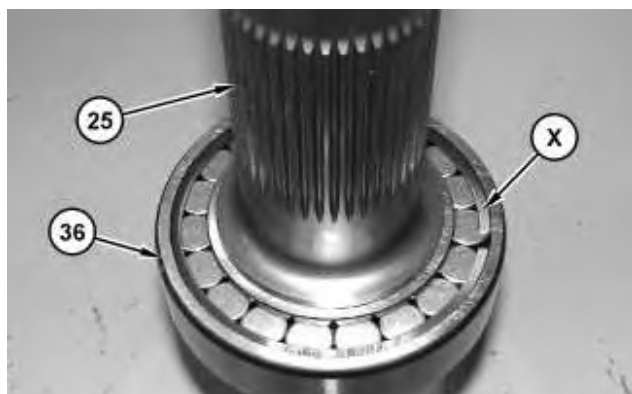

Illustration 8

g02421958

4. Use a suitable press to install bearing (36) and bearing (37) onto shaft assembly (25). Bearing (36) must be installed with Retaining Clip (X) toward the barrel assembly.
-

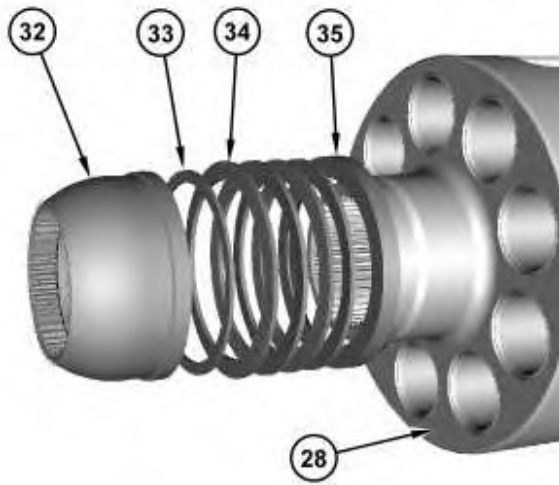

Illustration 9

g02420596

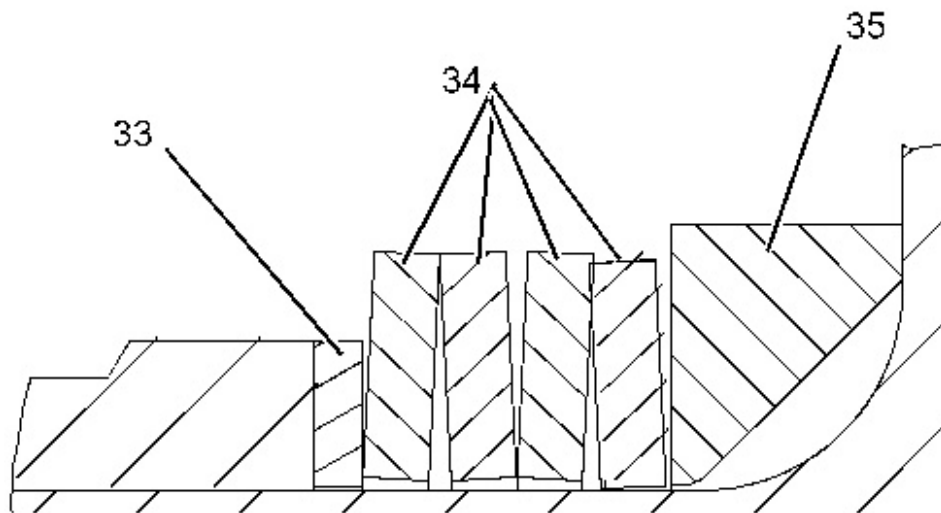

Illustration 10

g02423556

5. Install barrel spacer (35), Belleville washers (34), thin shim (33), and bearing (32) onto barrel assembly (28).
-

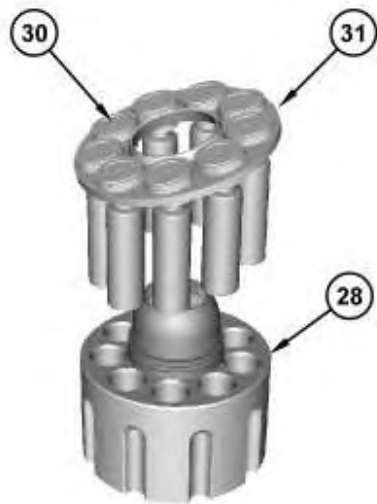

Illustration 11

g02420578

6. Install pistons (30) and plate (31) onto barrel assembly (28).
-

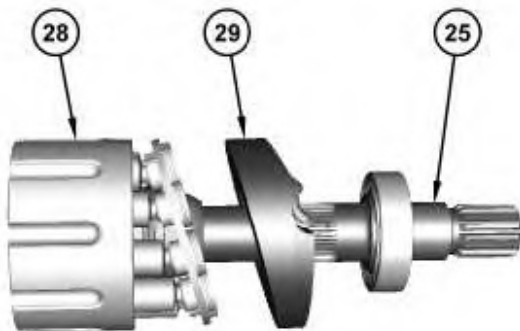

Illustration 12

g02420544

7. Install swashplate (29) and barrel assembly (28) onto shaft assembly (25).
-

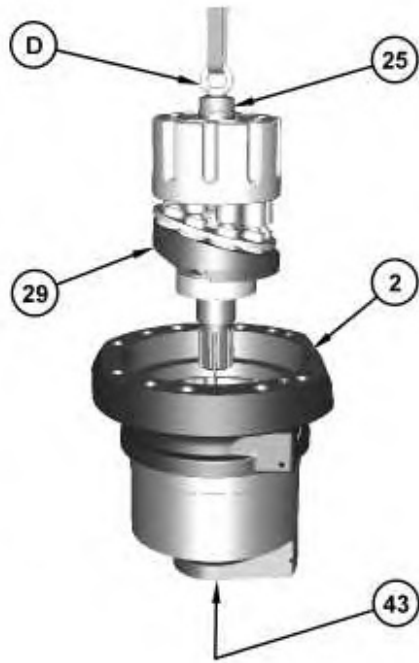

Illustration 13

g02423621

8. Use Tooling (D) and a suitable lifting device to install the rotating group into motor housing (2). The weight of the rotating group is approximately 30 kg (65 lb).

Note: Align the notches of swashplate (29) with the keys in the motor housing (2).

Note: Protect shaft seal (43) from damage by covering the splines on shaft assembly (25) with heat shrink tubing.



Illustration 14

g02423738

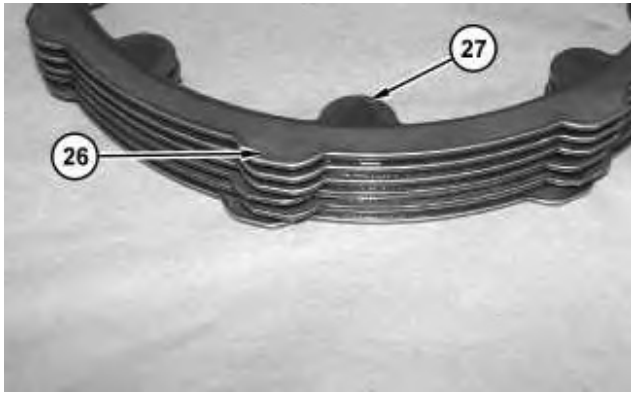

Illustration 15

g02423742

9. Install plates (26) and friction discs (27). Start with plate (26). Alternate between plates (26) and friction discs (27) with plates (26) on the top and the bottom.

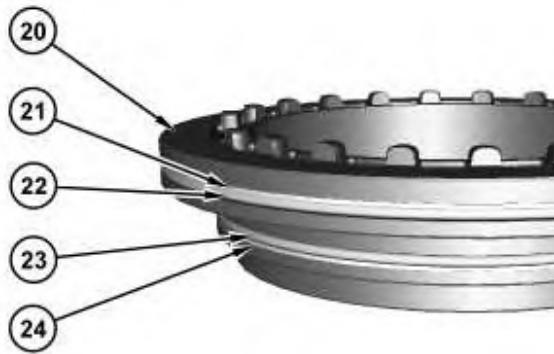

Illustration 16

g02419659

10. Install backup ring (21) and O-ring seal (22) onto brake piston (20).
11. Install backup ring (24) and O-ring seal (23) onto brake piston (20).

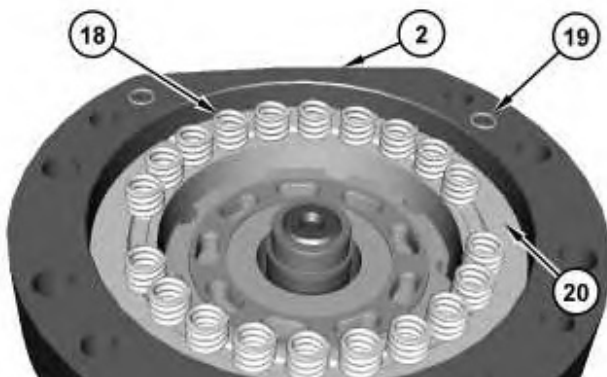

Illustration 17

g02419577

12. Install O-ring seals (19) onto motor housing (2). Install springs (18) onto brake piston (20).

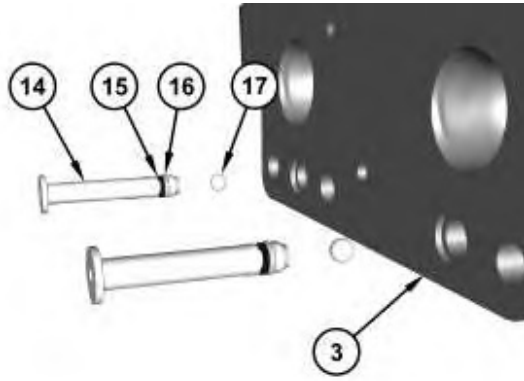

Illustration 18

g02419439

13. Install balls (17), backup rings (15), O-ring seals (16), and retainers (14) into head assembly (3).



Illustration 19

g02419416

 **WARNING**

Improper assembly of parts that are spring loaded can cause bodily injury.

To prevent possible injury, follow the established assembly procedure and wear protective equipment.

14. Install spring (13), spool (12), and adapter (11). Tighten adapter (11) to a torque of $115 \pm 10 \text{ N}\cdot\text{m}$ ($85 \pm 7 \text{ lb ft}$).



Suggest:

If the above button click is invalid.

Please download this document

first, and then click the above link

to download the complete manual.

Thank you so much for reading

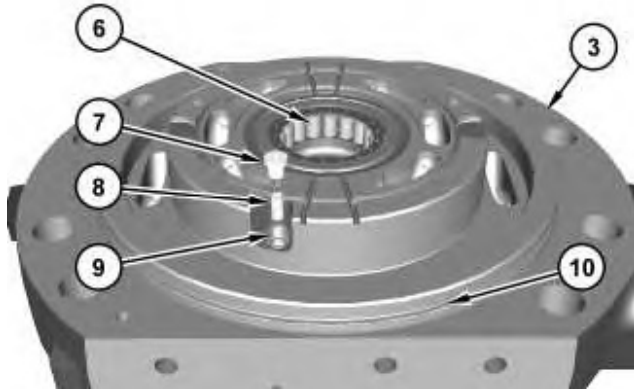

Illustration 20

g02419359

15. Install ball (9), spring (8), and orifice (7). Tighten orifice (7) to a torque of $7 \pm 1 \text{ N}\cdot\text{m}$ ($62 \pm 9 \text{ lb in}$).
16. Install bearing (6) and O-ring seal (10) onto head assembly (3).



Illustration 21

g02001974

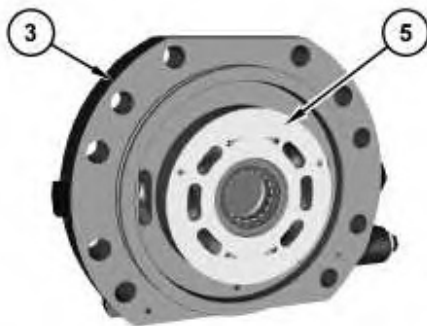

Illustration 22

g02419358

17. Apply Tooling (K) to the back side of plate (5) to hold plate (5) in place during assembly. Install plate (5) to head assembly (3).

<https://www.ebooklibonline.com>

Hello dear friend!

Thank you very much for reading.

Enter the link into your browser.

The full manual is available for immediate download.

<https://www.ebooklibonline.com>