



# Service Repair Manual

## **Models**

**329DL MOBILE HYD  
POWER UNIT Excavator**

---

[Previous Screen](#)

Product: MOBILE HYD POWER UNIT

Model: 329D L MOBILE HYD POWER UNIT L5G

Configuration: 329D L Mobile Hydraulic Power Units L5G00001-UP (MACHINE) POWERED BY C7 Engine

## Disassembly and Assembly 320 VH and VM Variable Gauge Undercarriage

Media Number -KENR8183-01

Publication Date -01/05/2012

Date Updated -24/05/2012

i04893712

## Final Drive - Disassemble

SMCS - 4050-015

## Disassembly Procedure

Table 1

Required Tools			
Tool	Part Number	Part Description	Qty
A	1P - 2420	Repair Stand	1
B	1U - 6400	Puller	1
C	5P - 8707	Plate	1
	1P - 0520	Driver Group	1
	5F - 7366	Forcing Bolt	1
	8T - 0207	Bolt	2
	3H - 0465	Puller Plate	2
	1P - 5546	Cross Block	1

### Start By:

- a. Remove the final drive.
-

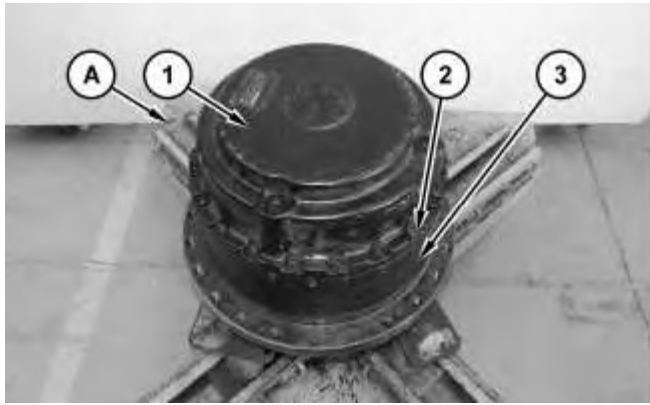

Illustration 1

g03034523

1. Secure final drive (3) to Tooling (A). The weight of the final drive is approximately 254 kg (560 lb). Remove bolts (2) and housing (1). Remove O-ring seal from housing (1).

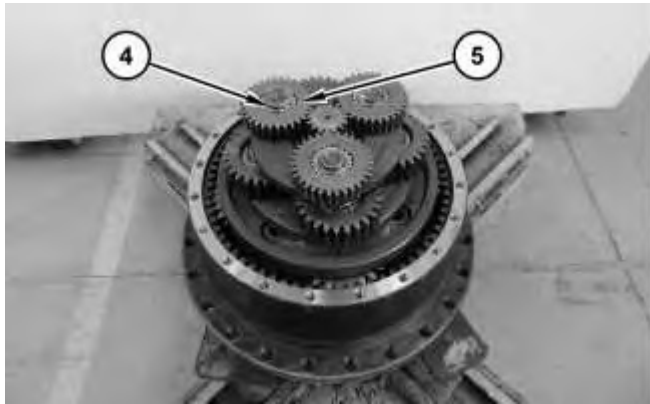

Illustration 2

g03034527

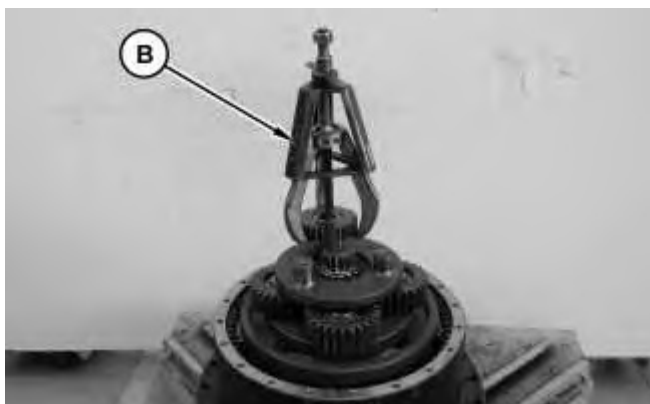

Illustration 3

g03034528

2. Remove retaining ring (4) and planet gear (5). If necessary, use Tooling (B) to remove planet gears (5).

**<https://www.ebooklibonline.com>**

Hello dear friend!

Thank you very much for reading.

Enter the link into your browser.

The full manual is available for immediate download.

**<https://www.ebooklibonline.com>**

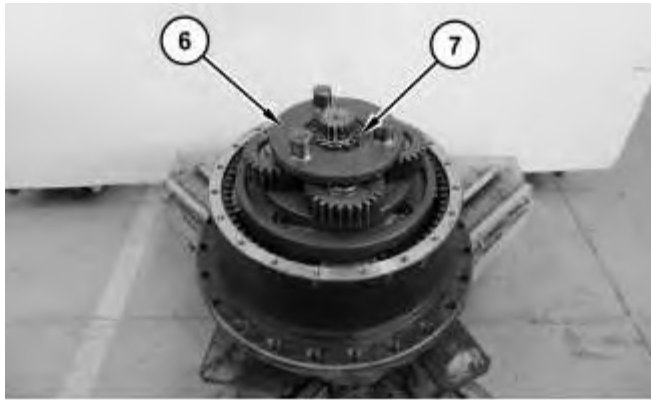

Illustration 4

g03034530

3. Remove retaining ring (7) and planet gear carrier (6).

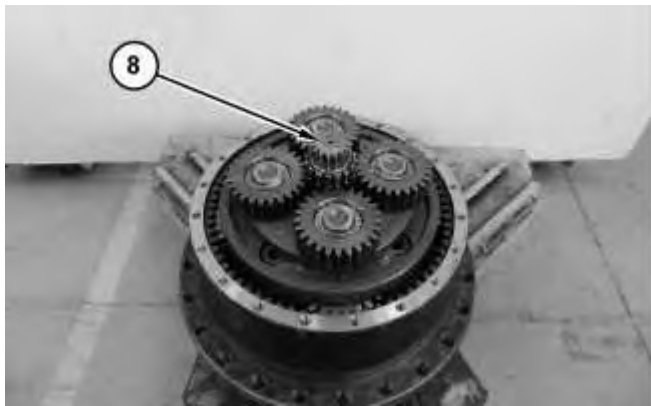

Illustration 5

g03034536

4. Remove sun gear (8).

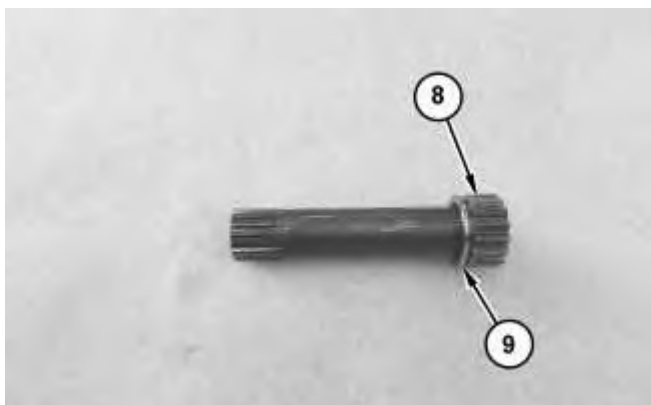

Illustration 6

g03034556

5. Remove spacer (9) from sun gear (8).

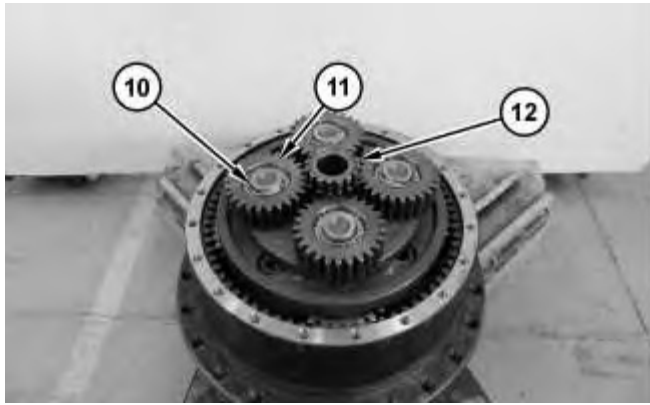

Illustration 7

g03034559

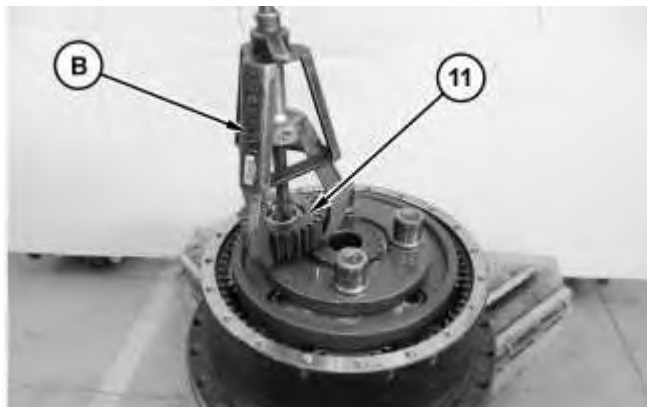

Illustration 8

g03034582

6. Remove sun gear (12) and remove retaining ring (10) and planet gears (11). If necessary, use Tooling (B) to remove planet gears (11).

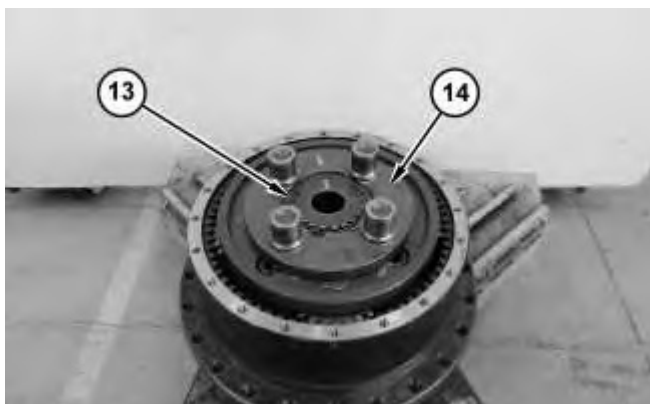

Illustration 9

g03034575

7. Remove retaining ring (13) and planet carrier (14).

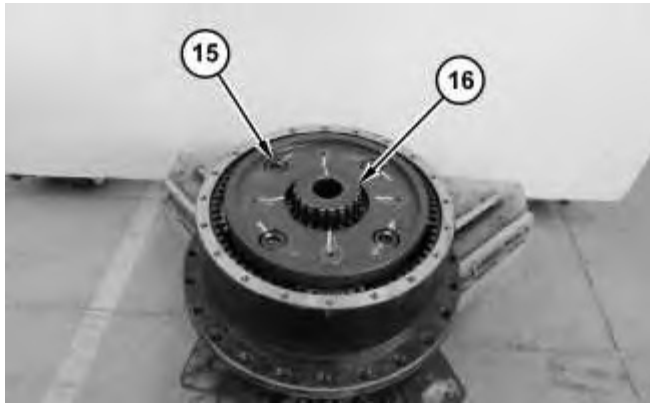

Illustration 10

g03034581

8. Remove sun gear (16) and remove bolt's (15).

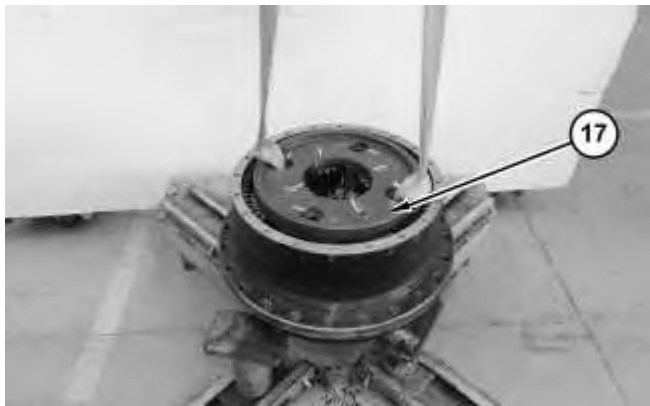

Illustration 11

g03034598

9. Attach suitable lifting device to planet carrier (17). The weight of planet carrier is approximately 32 kg (70 lb). Remove planet carrier (17).

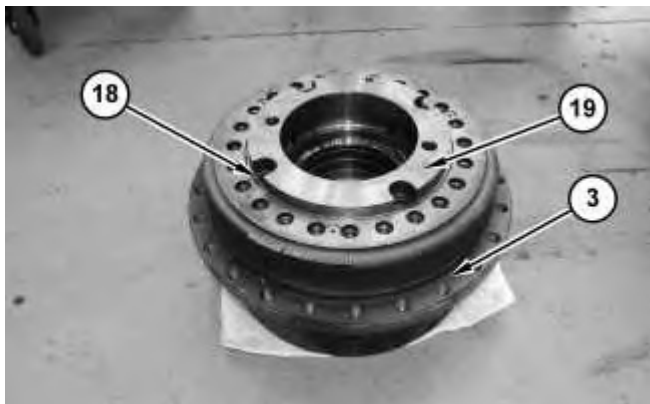

Illustration 12

g03034599

10. Remove final drive (3) from Tooling (A). Place final drive (3) on floor. The weight of final drive is approximately 163 kg (360 lb). Remove bolts (18) and flange (19).

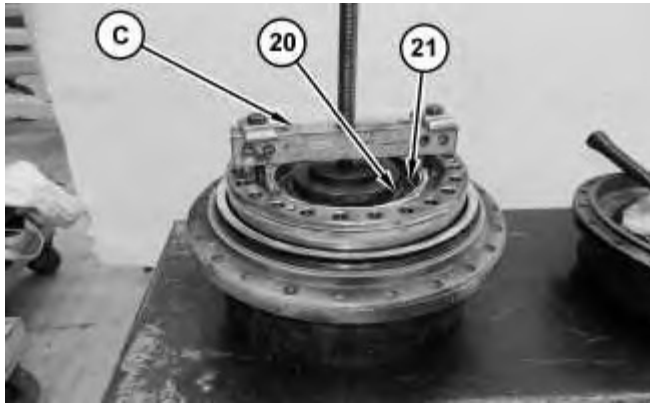

Illustration 13

g03034600

11. Use Tooling (C) to press down on the pushing disc (20), to remove retaining ring (21).

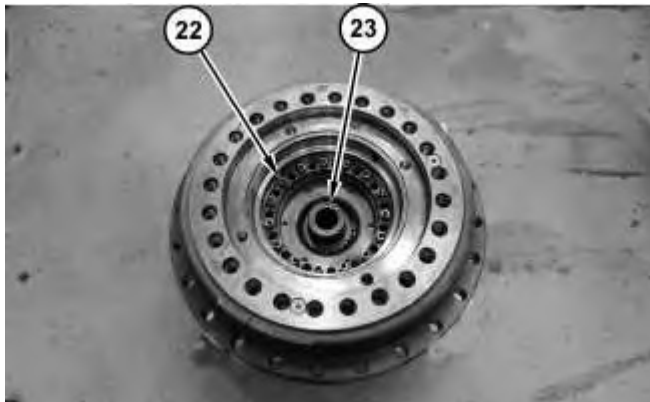

Illustration 14

g03034604

12. Remove springs (22) and brake shaft (23).

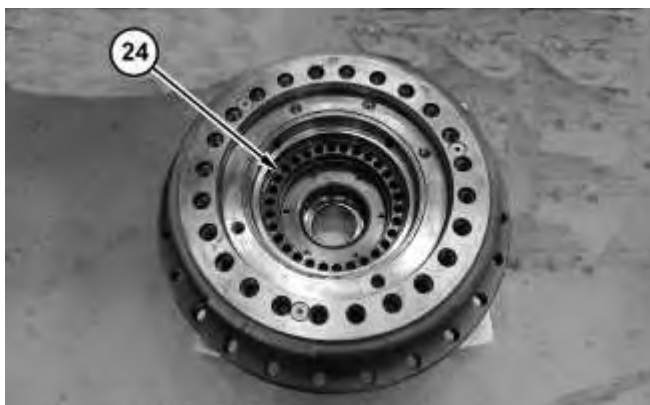

Illustration 15

g03034620

13. Remove piston (24).

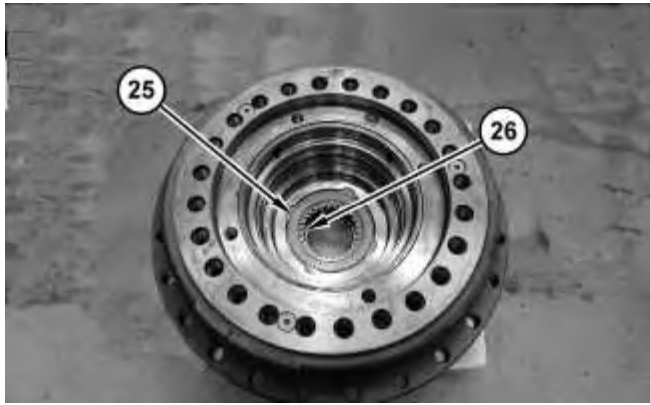

Illustration 16

g03034621

14. Remove plates (25) and discs (26) .

**Note:** Note the order at which the friction discs and plates are removed. For installation purposes.

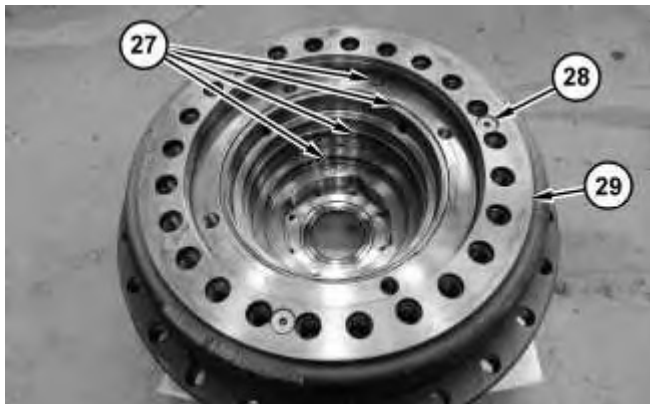

Illustration 17

g03034698

15. Remove O-ring seals (27), cap screws (28) and cover (29).



Illustration 18

g03034716

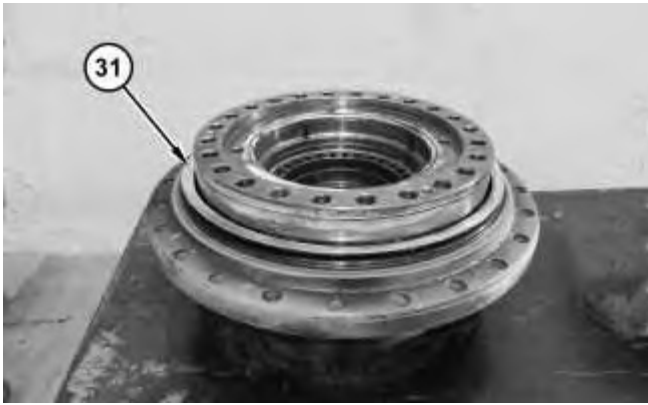

---

Illustration 19

g03034718

16. Remove Duo-Cone seal (30) and Duo-Cone seal (31).

[Previous Screen](#)

Product: MOBILE HYD POWER UNIT

Model: 329D L MOBILE HYD POWER UNIT L5G

Configuration: 329D L Mobile Hydraulic Power Units L5G00001-UP (MACHINE) POWERED BY C7 Engine

## Disassembly and Assembly 320 VH and VM Variable Gauge Undercarriage

Media Number -KENR8183-01

Publication Date -01/05/2012

Date Updated -24/05/2012

i03508206

## Final Drive - Disassemble

SMCS - 4050-015

S/N - J9D1-UP

S/N - L5G1-UP

## Disassembly Procedure

Table 1

Required Tools			
Tool	Part Number	Part Description	Qty
A	1P-2420	Transmission Repair Stand	1
B	138-7573	Link Bracket	2
C	1P-1863	Retaining Ring Pliers	1
D	138-7575	Link Bracket	3
E	4C-8359	Eyebolt	2
F	138-7574	Link Bracket	2
G	138-7576	Link Bracket	2

### Start By:

- a. Start by removing the final drive. Refer to Disassembly and Assembly, "Final Drive - Remove".

**Note:** Cleanliness is an important factor. Before the disassembly procedure, the exterior of the component should be thoroughly cleaned. This will prevent dirt from entering the internal mechanism.

1. Put an alignment mark across the sections of the final drive for assembly purposes. The parts must be reinstalled to the original locations.



Illustration 1

g00892878

2. Use Tooling (G) and a suitable lifting device to position the final drive assembly onto Tooling (A). The weight of the final drive assembly is approximately 550 kg (1200 lb).
3. Remove bolts (1).

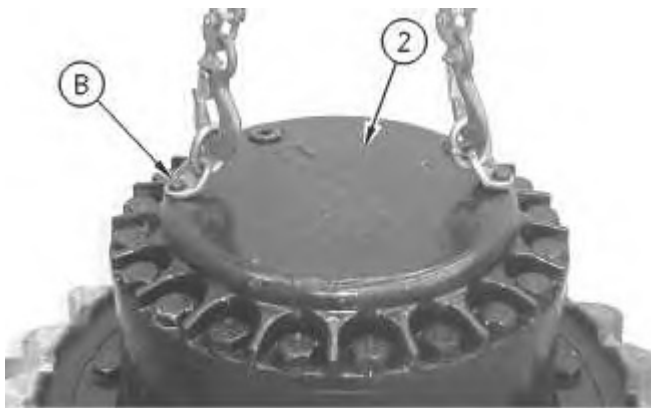

Illustration 2

g00892883

4. Use Tooling (B) and a suitable lifting device to remove cover (2). The weight of cover (2) is approximately 32 kg (70 lb).



5. Remove bolts (3) and gear (4). Check plate (6). Replace plate (6) if plate (6) is worn. Remove plugs (5) from cover (2).



6. Remove O-ring seals (7) from plugs (5).



7. Remove gear (8) and spacer (9).



8. Use Tooling (C) to remove retaining ring (10). Remove washer (11) and gear (12). Remove bearing assembly (13) and washer (14).
9. Repeat Step 8 for the other two gear assemblies.

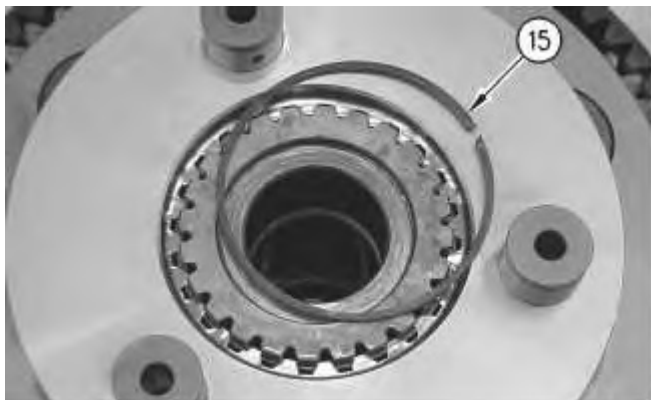

Illustration 7

g00892968

10. Remove retaining ring (15).



Illustration 8

g00892975

11. Remove carrier assembly (16).
-

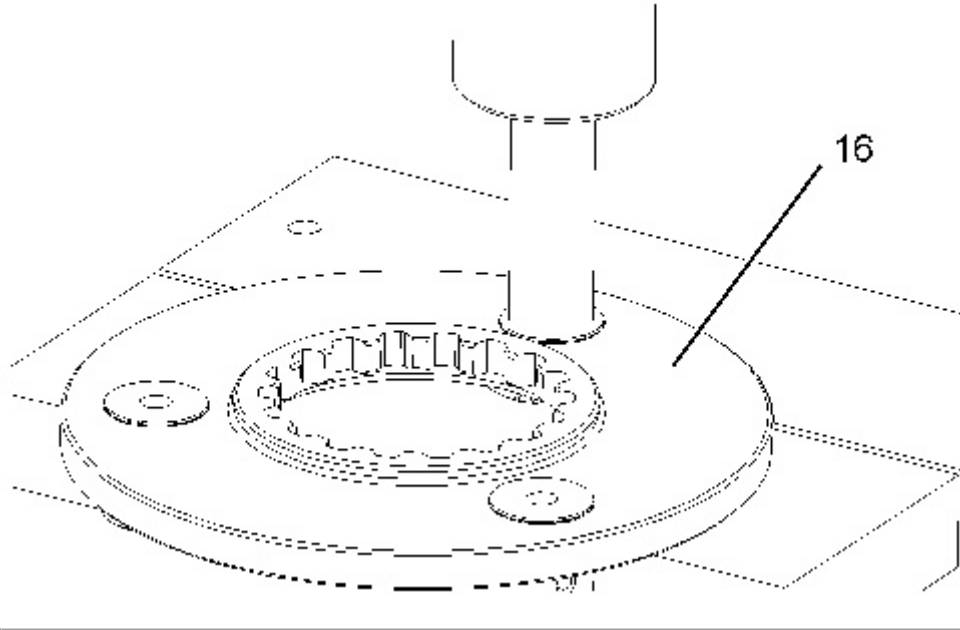

Illustration 9

g01389804

12. Use a suitable press to remove the shafts from carrier assembly (16).

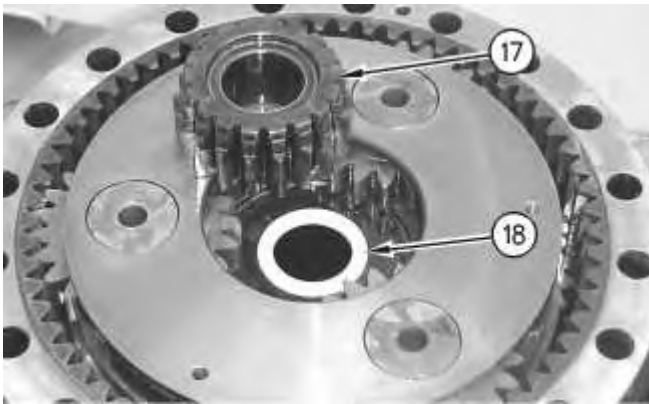

Illustration 10

g00892977

13. Remove gear (17) and spacer (18).

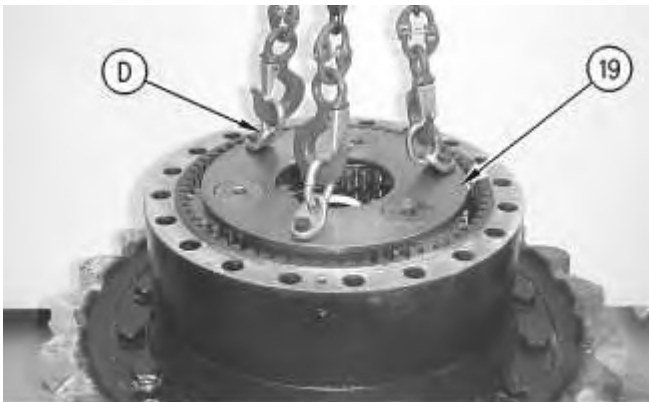

Illustration 11

g00892997

14. Use Tooling (D) and a suitable lifting device to remove planetary carrier (19). The weight of planetary carrier (19) is approximately 48 kg (105 lb).

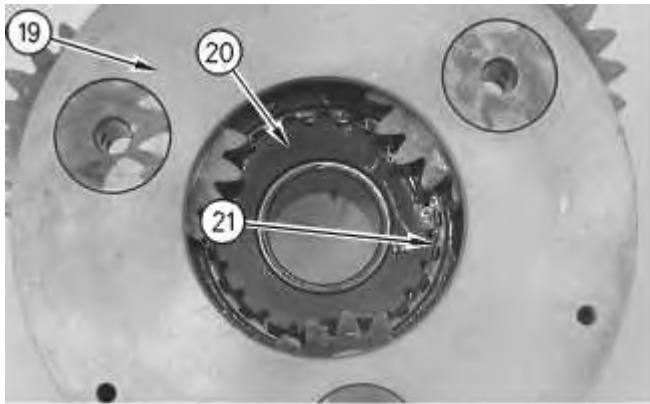

Illustration 12

g00893019

15. Remove retaining ring (21). Lift planetary carrier (19) off sun gear (20).



Illustration 13

g00896860

16. Drive spring pin (23) into planetary shaft (22).



Illustration 14

g00893043

17. Remove planetary shaft (22). Use a suitable punch to remove spring pin (23) from planetary shaft (22).

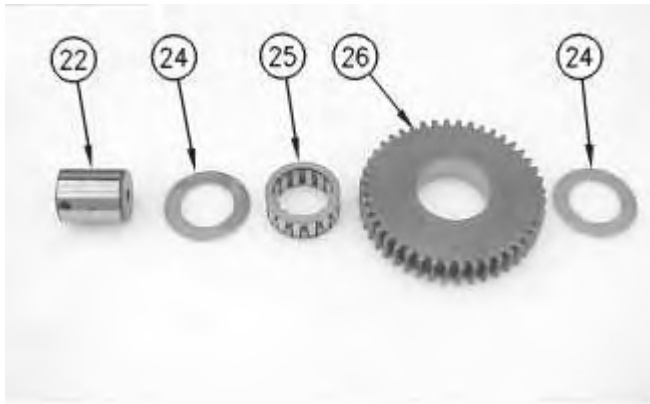

Illustration 15

g00896863

18. Remove washers (24) and bearing (25) from planetary gear (26).  
19. Repeat Steps 16 through 18 for the other two planetary gears.

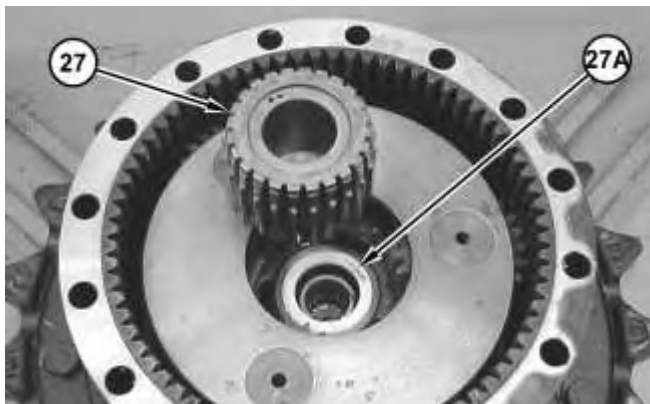

Illustration 16

g01842853

20. Remove gear (27). Remove spacer (27A).



Illustration 17

g01842974

21. Use two people to remove carrier assembly (28). The weight of carrier assembly (28) is approximately 38 kg (85 lb).



Illustration 18

g01843140

22. Drive spring pin (30) into shaft (29).



Illustration 19

g00893658

23. Remove shaft (29). Use a suitable punch to remove spring pin (30) from shaft (29).

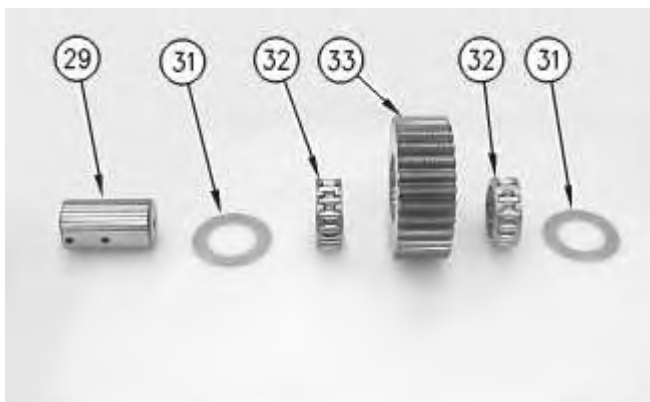

Illustration 20

g00893674

24. Remove washers (31) and bearings (32) from planetary gear (33).

25. Repeat Steps 22 through 24 for the other three planetary gears.



Illustration 21

g01208300

26. Fasten Tooling (E) and a suitable lifting device to ring gear (34), as shown. Remove ring gear (34) from sprocket housing (35). The weight of ring gear (34) is approximately 66 kg (146 lb).

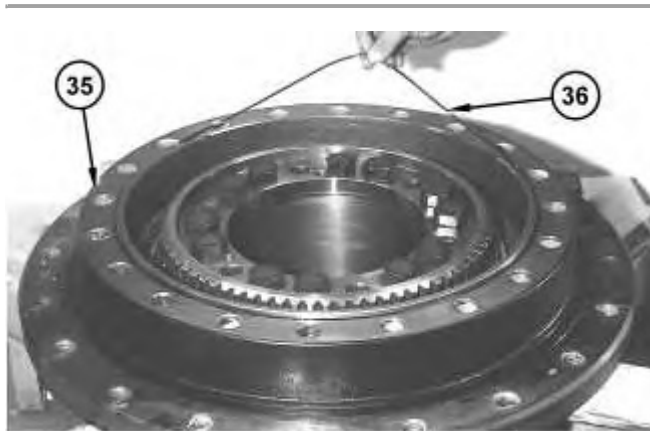

Illustration 22

g01208542

27. Remove O-ring seal (36) from sprocket housing (35).

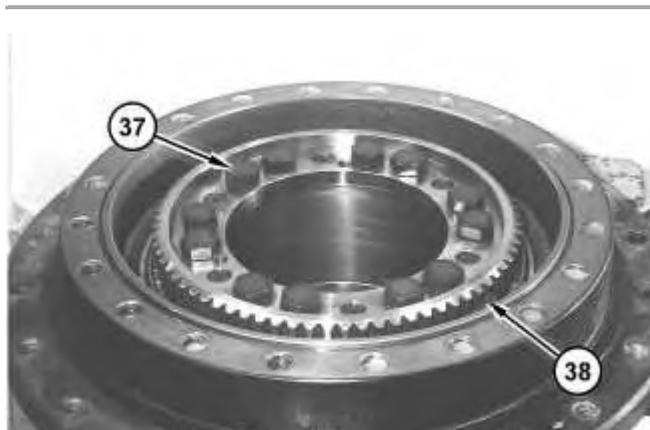

Illustration 23

g01208553

28. Remove bolts (37) from coupling gear (38).

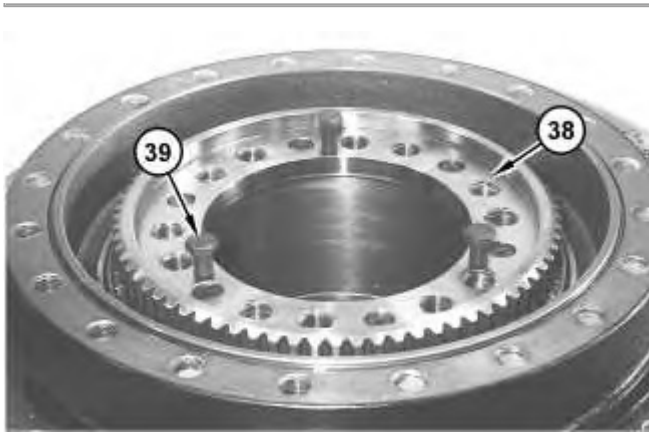

Illustration 24

g01208572

29. Install suitable forcing bolts (39) in coupling gear (38). Tighten the forcing bolts evenly in order to loosen coupling gear (38). Remove the coupling gear from the motor housing.



Illustration 25

g01208578



Illustration 26

g01208625

30. Remove shims (40) from the motor housing.

**Note:** Inner cones and outer bearing cones (42) are a slip fit on the motor housing. While you remove sprocket housing (35) from the motor housing, inner bearing cone (42) may stay with the sprocket housing or the inner bearing cone may stay on the motor housing.

31. Fasten Tooling (F) and a suitable lifting device to sprocket housing (35). Separate the sprocket housing from the motor housing. The weight of sprocket housing (35) is approximately 109 kg (240 lb).



Illustration 27

g01208626

32. Remove the locating pins from the motor housing.
33. Remove Duo-Cone seal (41) from the motor housing.
34. If inner bearing cone (42) remained on the motor housing, then remove the inner bearing cone.



Illustration 28

g01208633

35. Remove Duo-Cone seal (43) from the sprocket housing.
36. If inner bearing cone (42) remained on the sprocket housing, then remove the inner bearing cone.
37. Remove the bearing cups from the sprocket housing.

[Previous Screen](#)

Product: MOBILE HYD POWER UNIT

Model: 329D L MOBILE HYD POWER UNIT L5G

Configuration: 329D L Mobile Hydraulic Power Units L5G00001-UP (MACHINE) POWERED BY C7 Engine

## Disassembly and Assembly 320 VH and VM Variable Gauge Undercarriage

Media Number -KENR8183-01

Publication Date -01/05/2012

Date Updated -24/05/2012

i06146851

## Final Drive - Assemble

SMCS - 4050-016

## Assembly Procedure

Table 1

Required Tools			
Tool	Part Number	Part Description	Qty
A	1P - 2420	Repair Stand	1
B	1U - 6400	Puller	1
C	5P - 8707	Plate	1
	1P - 0520	Driver Group	1
	5F - 7366	Forcing Bolt	1
	8T - 0207	Bolt	2
	3H - 0465	Puller Plate	2
	1P - 5546	Cross Block	1
D	161 - 4350	Duo-Cone Seal Installer	1
	165 - 5192	Cord Stock	1
E	1U-5933	Installer	1

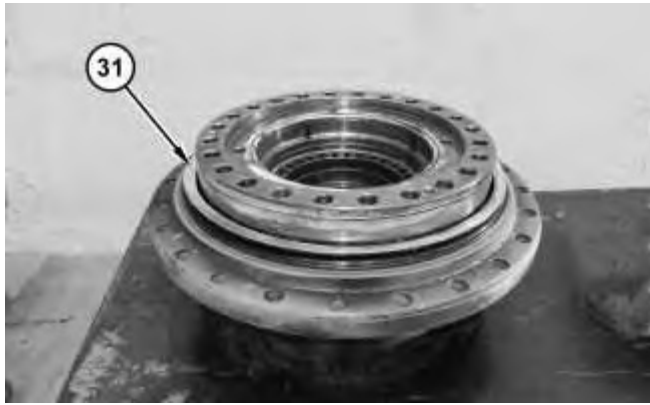

Illustration 1

g03034756

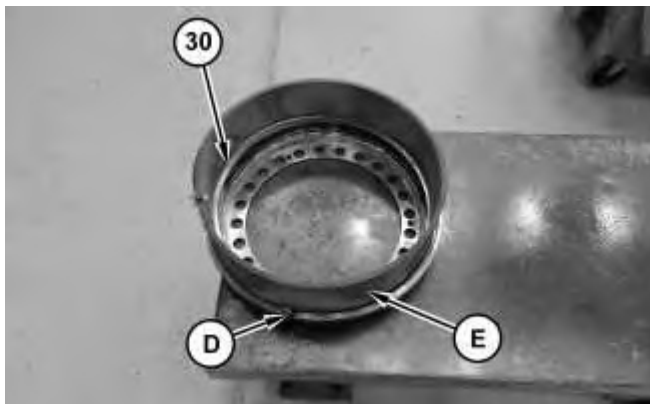

Illustration 2

g03034757

1. Use Tooling (E) and Tooling (D) to assemble Duo-Cone seal (28) . Use Tooling (E) to install Duo-Cone seal (29) .

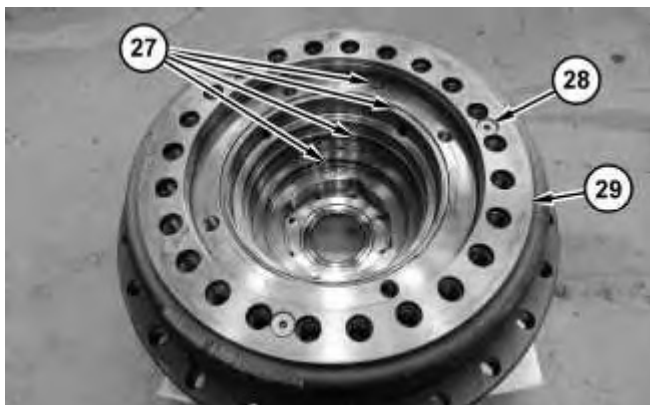

Illustration 3

g03034776

2. Install O-ring seals (27) and cover (29) Install cap screws (28) . Tighten cap screws (28) to a torque of 50 N·m (36 lb ft).



**Suggest:**

**If the above button click is invalid.**

**Please download this document**

**first, and then click the above link**

**to download the complete manual.**

**Thank you so much for reading**

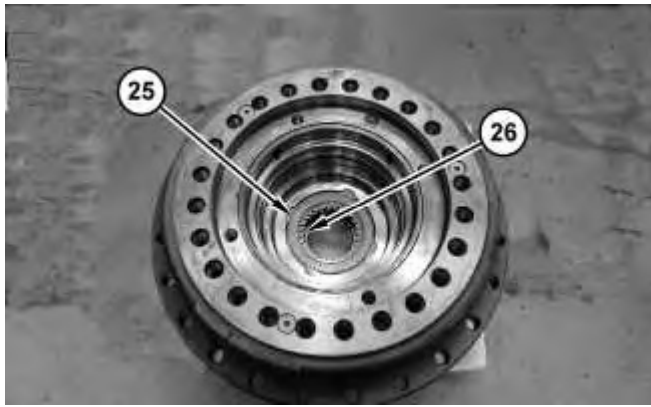

Illustration 4

g03034777

3. Install plates (25) and discs (26) .

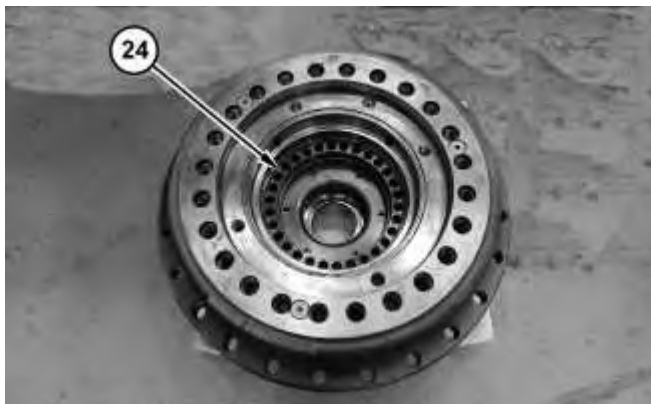
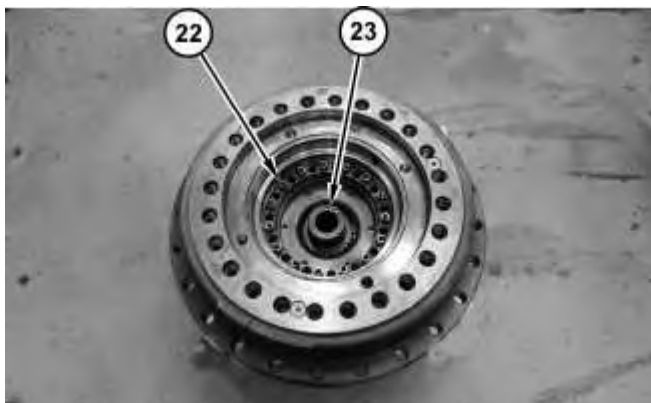

Illustration 5

g03034779

4. Install piston (24) .



**<https://www.ebooklibonline.com>**

Hello dear friend!

Thank you very much for reading.

Enter the link into your browser.

The full manual is available for immediate download.

**<https://www.ebooklibonline.com>**