



# Service Repair Manual

## **Models**

325F LCR and 325F L Excavator

---

[Previous Screen](#)

Product: EXCAVATOR

Model: 325F LCR EXCAVATOR YCA

Configuration: 325F L Excavators YCA00001-UP (MACHINE) POWERED BY C4.4 Engine

## Disassembly and Assembly 325F Excavator Machine Systems

Media Number -UENR6794-05

Publication Date -01/09/2018

Date Updated -18/09/2018

i01894489

# Travel Motor - Disassemble

SMCS - 4351-015

## Disassembly Procedure

Table 1

Required Tools			
Tool	Part Number	Part Description	Qty
A	8T-6699	Bolt	2
	126-7183	Crossblock	1
	126-7181	Sliding Plate	2
B	8H-0663	Bearing Puller Gp	1

### Start By:

- a. Remove the travel motor. Refer to Disassembly and Assembly, "Travel Motor - Remove".

---

### NOTICE

Care must be taken to ensure that fluids are contained during performance of inspection, maintenance, testing, adjusting, and repair of the product. Be prepared to collect the fluid with suitable containers before opening any compartment or disassembling any component containing fluids.

Refer to Special Publication, NENG2500, "Dealer Service Tool Catalog" for tools and supplies suitable to collect and contain fluids on Cat<sup>®</sup> products.

**Dispose of all fluids according to local regulations and mandates.**

---

**Note:** Thoroughly clean the outside of the travel motor prior to disassembly.

1. Fasten the travel motor to a suitable lifting device in a vertical position. The weight of the travel motor is approximately 60 kg (132 lb).

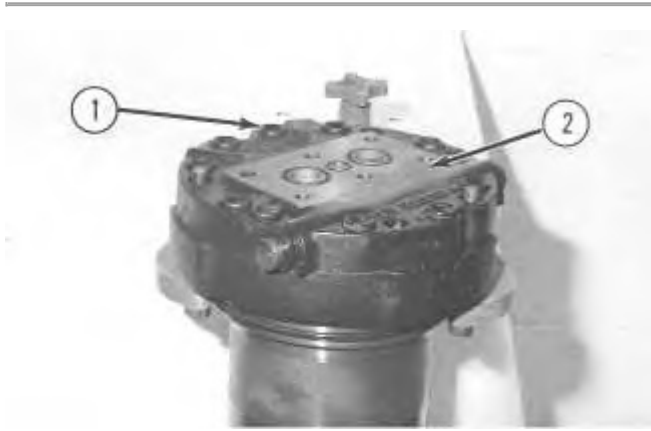

Illustration 1

g00510326

**Note:** Put an alignment mark across the head and the body of the travel motor for assembly purposes. The head must be reinstalled in the head's original position on the body of the travel motor.

**Note:** During the removal of head (2) from the body of the travel motor, be careful not to damage the mating surfaces of the components.

2. Remove socket head bolts (1).
3. Remove head (2) from the body of the travel motor.

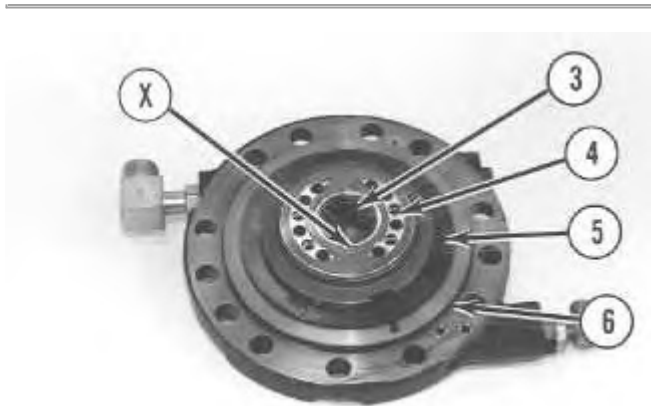

Illustration 2

g01000121

**<https://www.ebooklibonline.com>**

Hello dear friend!

Thank you very much for reading.

Enter the link into your browser.

The full manual is available for immediate download.

**<https://www.ebooklibonline.com>**

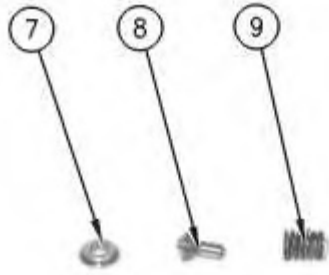

Illustration 3

g01000122

 **WARNING**

**Personal injury can result from being struck by parts propelled by a released spring force.**

**Make sure to wear all necessary protective equipment.**

**Follow the recommended procedure and use all recommended tooling to release the spring force.**

4. Turn over head (2).
5. Remove O-ring seal (6), shims (5), port plate (4), and bearing (3) from the head.
6. Remove the check valve assemblies from the head.

**Note:** There is a retainer under spring (9). This retainer is a press fit in head (2). Do not remove the retainer.

7. Insert a dowel rod with a small diameter into Hole (X). Tap the dowel rod with a plastic hammer in order to remove spring (9), poppet (8) and seat (7) from the head.



- Remove fittings (10) and plugs (11) from the head. Remove the O-ring seal from each fitting.



Illustration 5

- Remove O-ring seals (12) and washer set (13) from the body of the travel motor.
- Use Tooling (A) and low air pressure to remove brake piston (14). Remove brake piston (14) from the body of the travel motor.

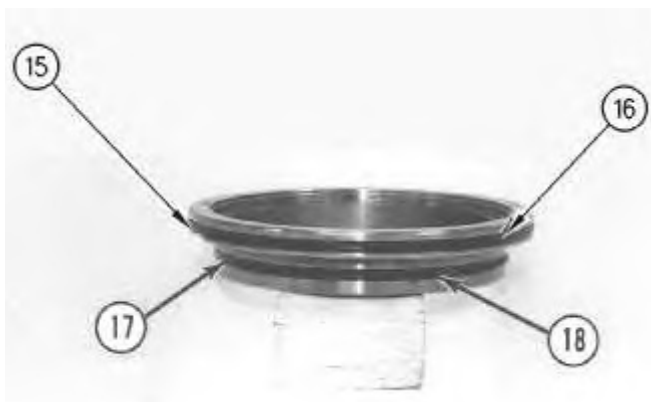

Illustration 6

- Remove O-ring seal (15) from the brake piston. Remove backup ring (16) from the brake piston.
  - Remove O-ring seal (17) from the brake piston. Remove backup ring (18) from the brake piston.
-



Illustration 7

g01000128

13. Remove piston guide (19), five friction plates (20), and the four steel plates from the body of the travel motor.



Illustration 8

g01000129

14. Remove O-ring seal (21) from the piston guide. Remove backup ring (22) from the piston guide.

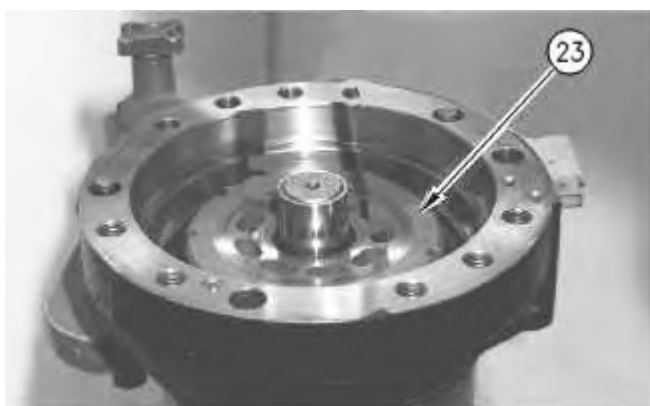

Illustration 9

g01002383

**Note:** Do not allow the components of barrel assembly (23) to come apart during the removal from the travel motor. All of the components in the barrel assembly must be reinstalled in the component's original location.

15. Slowly remove barrel assembly (23) from the body of the travel motor. Do not allow the components to fall apart.



Illustration 10

g00510502

**Note:** Shoe retainer (24) and piston shoe assemblies (25) are serviced as a group. Prior to the removal of the shoe retainer and the piston shoe assemblies from barrel (26), put identification marks on piston shoe assemblies (25) for assembly purposes. Identification marks are used to identify the piston shoe assembly's location in shoe retainer (24) and barrel (26). The piston shoe assemblies must be reinstalled in the piston shoe assembly's original bores in the shoe retainer and the barrel.

16. Remove shoe retainer (24) and piston shoe assemblies (25) from barrel (26). Separate the piston shoe assemblies from the shoe retainer.



Illustration 11

g00510504

17. Remove guide (27), spacer (28), and springs (29) from the barrel.
-



Illustration 12

g01000131

18. Remove cam plate (30) from the body of the travel motor.

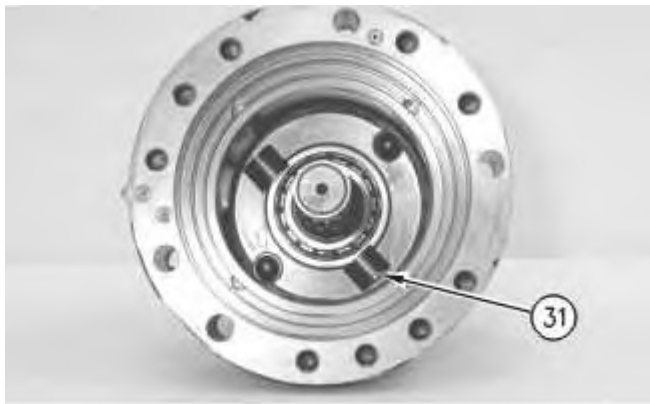

Illustration 13

g00510550

19. Remove two keys (31) and the two locating pins (not shown) from the body of the travel motor.

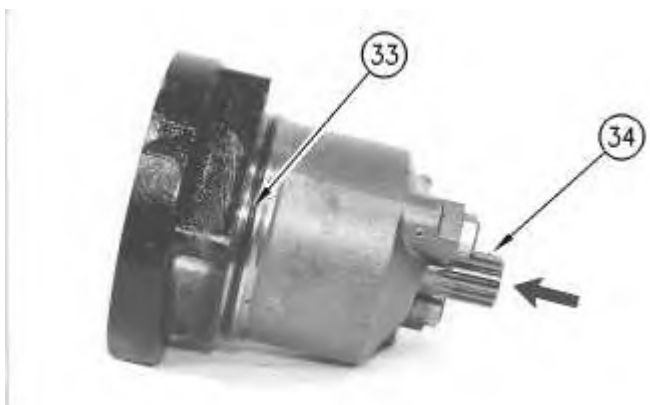

Illustration 14

g01000132

20. Remove O-ring seal (33) from the body of the travel motor.

21. Use a soft faced hammer to remove shaft assembly (34) from the body of the travel motor. Remove the shaft assembly in the direction that is indicated by the arrow.

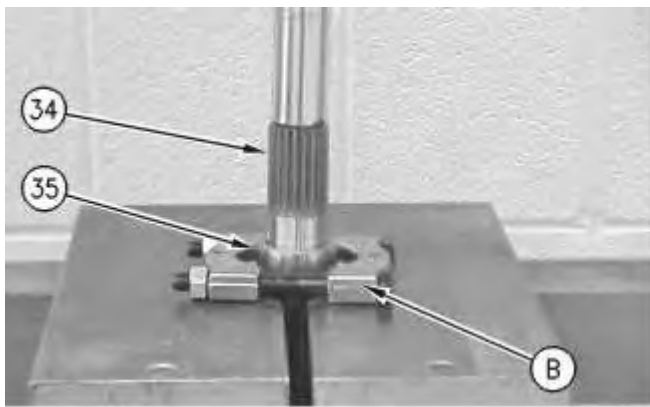

Illustration 15

g01000133

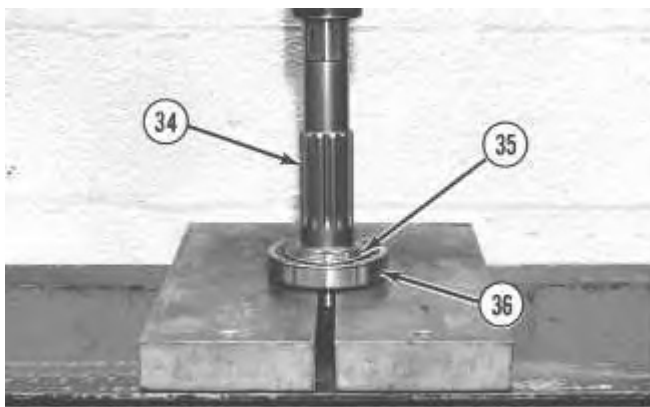

Illustration 16

g00510595

22. Remove retaining rings (35) from each side of bearing (36). Use Tooling (B) to remove bearing (36). Push shaft (34) out of bearing (36) with a press.

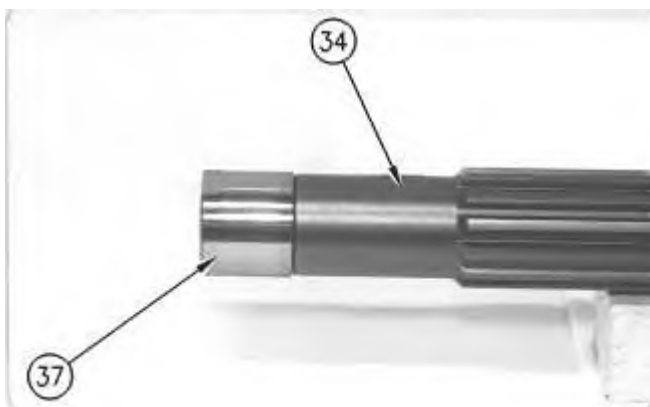

Illustration 17

g01000136

23. Remove inner race (37) from shaft assembly (34).



Illustration 18

g01000138

24. Remove lip seal (38) from the body of the travel motor.



Illustration 19

g00510605

25. Remove two stoppers (39) and the two pistons from the body of the travel motor.

[Previous Screen](#)

Product: EXCAVATOR

Model: 325F LCR EXCAVATOR YCA

Configuration: 325F L Excavators YCA00001-UP (MACHINE) POWERED BY C4.4 Engine

## Disassembly and Assembly 325F Excavator Machine Systems

Media Number -UENR6794-05

Publication Date -01/09/2018

Date Updated -18/09/2018

i01894672

# Travel Motor - Assemble

SMCS - 4351-016

## Assembly Procedure

Table 1

Required Tools			
Tool	Part Number	Part Description	Qty
C	1P-0510	Driver Gp	1
D	5P-3413	Pipe Sealant	1
E	9S-3263	Thread Lock Compound	1
F	1U-6396	O-Ring Assembly Compound	1
G	5P-0960	Molybdenum Grease	1

1. Make sure that all of the components of the travel motor are thoroughly clean and free of dirt and debris prior to assembly.

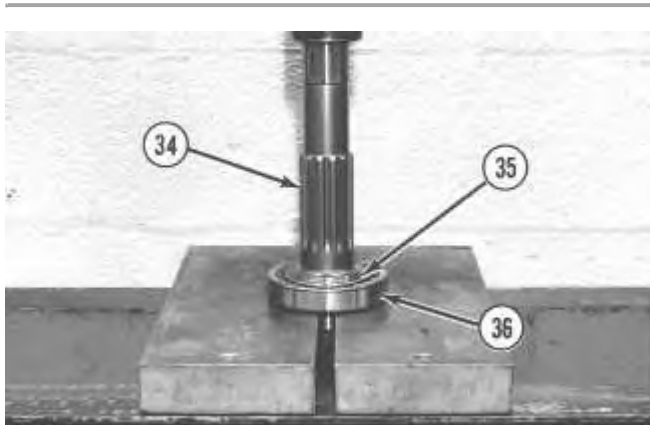

2. Install retaining ring (35) in the groove on shaft assembly (34).
3. Raise the temperature of bearing (36). Install bearing (36) on shaft assembly (34). Install the bearing until the bearing contacts the retaining ring.
4. Install the other retaining ring on the opposite side of bearing (36).

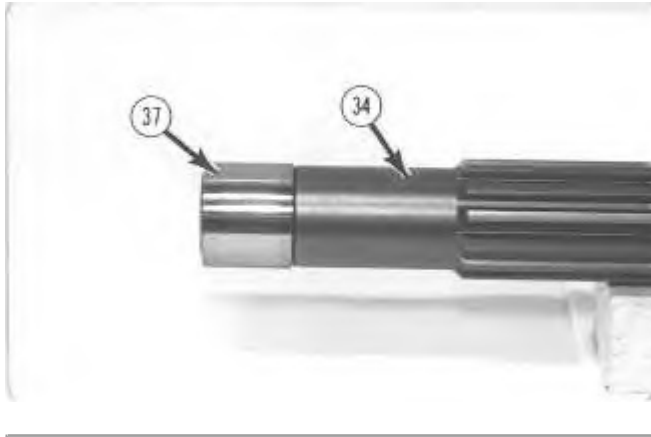

Illustration 2

5. Install inner race (37) on the end of shaft assembly (34) until the inner race is seated against the shoulder on the shaft assembly.

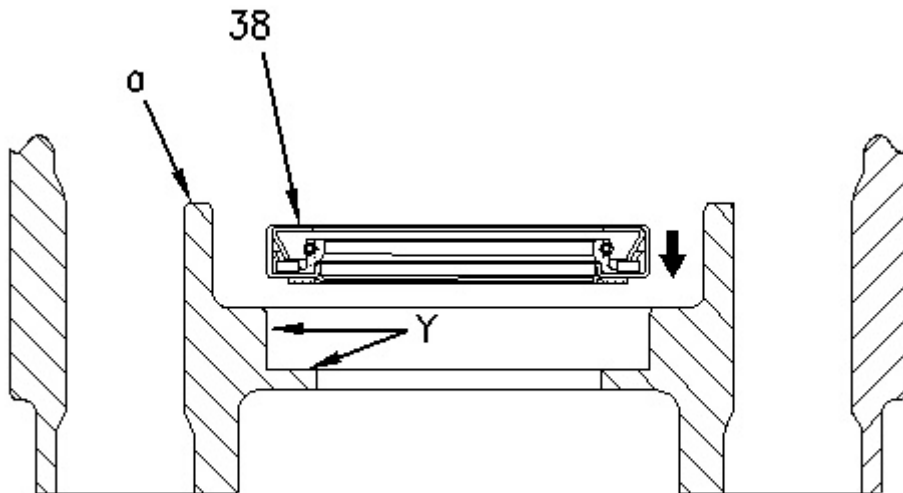

Illustration 3

(a) Body

6. Use Tooling (D) to apply a thin coat on Surfaces (Y) of the body of the travel motor.
7. Use Tooling (C) in order to install lip seal (38).

8. Install lip seal (38) in the body of the travel motor. Install the lip seal so that the sealing lip is facing in the direction that is shown. Make sure that the lip seal contacts the counterbore in the body of the travel motor.

**Note:** Slowly rotate shaft assembly (34) during the installation in order to make sure that the shaft assembly does not bind in the body of the travel motor.

9. Apply clean hydraulic oil on the lip of lip seal (38).
10. Use a press to install shaft assembly (34) in the body of the travel motor. Slowly rotate the shaft during the installation in order to make sure that the shaft does not bind. Make sure that the bearing on the shaft contacts the counterbore in the body of the travel motor.

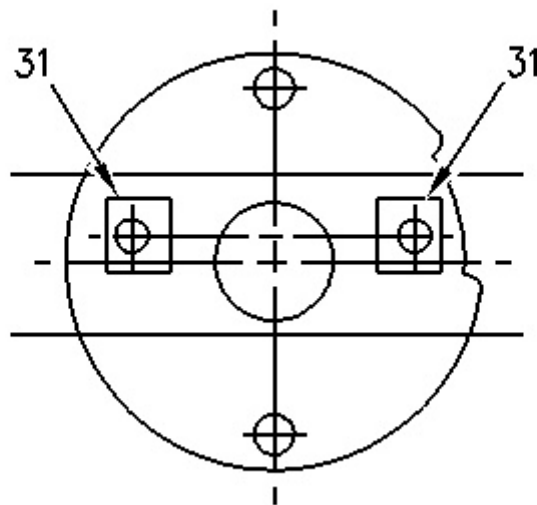

---

Illustration 4

g00651960

---

### NOTICE

**The locating pin on each key is not centered. In order to prevent damage to the barrel assembly during assembly of the travel motor, the keys must be installed as shown. Also, the keys must be installed in the key's original location in the body of the travel motor.**

---

11. Install the two locating pins and two keys (31) in the body of the travel motor, as shown.
-

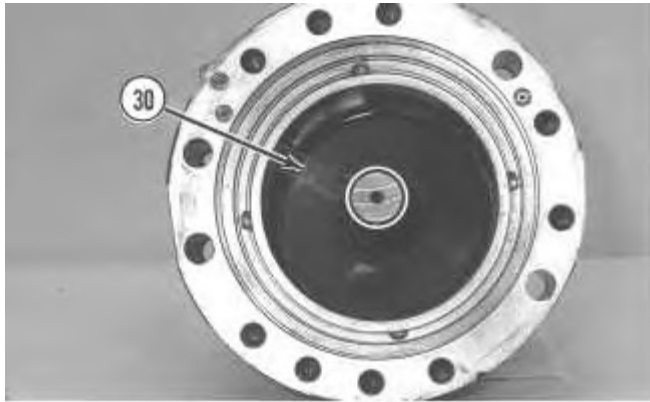

Illustration 5

g00510547

12. Install cam plate (30) in the body of the travel motor in the cam plate's original location. Make sure that the two pistons and two keys (31) in the body of the travel motor engage properly with the cam plate.

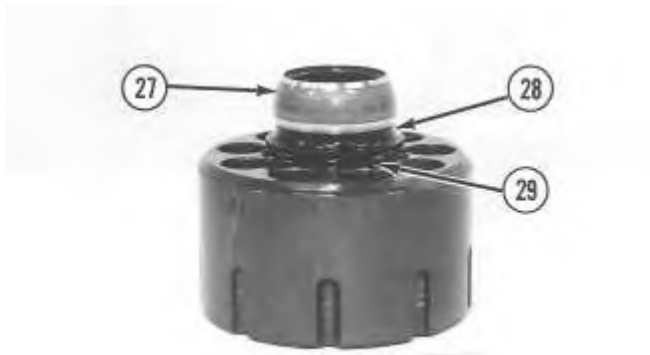

Illustration 6

g00510504

13. Install springs (29) in the barrel. Install spacer (28) and guide (27) on the barrel.



Illustration 7

g00878253

14. Install piston shoe assemblies (25) in the piston shoe assembly's original bores in shoe retainer (24).

15. Apply clean hydraulic oil in the bores of the barrel and on piston shoe assemblies (25). Install the piston shoe assemblies with the shoe retainer in the piston shoe assembly's original bore in barrel (26).

---

### NOTICE

**Make sure that the cam plate is correctly engaged with the two pistons in the body of the travel motor prior to installing the barrel assembly.**

**When the body of the travel motor is tilted to allow the installation of the barrel assembly, the cam plate can slide off of the two pistons. The remaining parts of the travel motor can be assembled with the cam plate in the incorrect position.**

**Extensive damage will result from the incorrect installation of the cam plate. Follow the exact installation procedure to prevent damage.**

---

16. Apply clean hydraulic oil on the sliding surfaces of the cam plate, on the piston shoe assemblies and on the splined shaft of the travel motor.

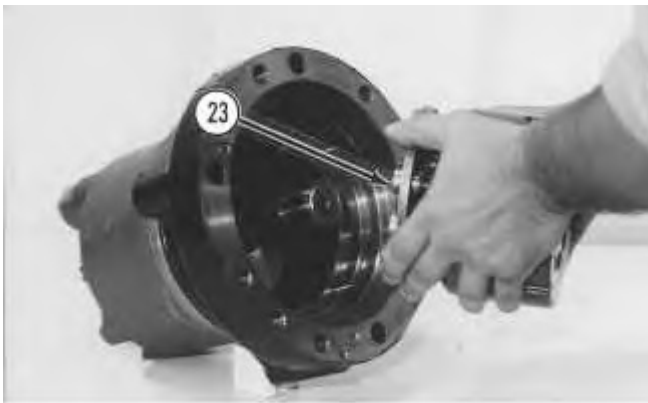
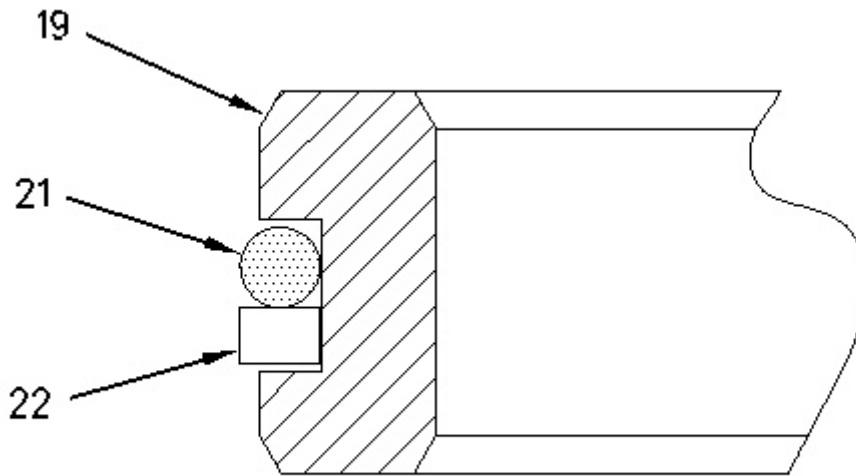

Illustration 8

g00485953

17. Route a piece of strong string through an opening for the cam plate tension adjusters. Route the string over the sliding surface of cam plate (30) and through the opposite opening for the cam plate tension adjusters. Hold the string taut in order to keep cam plate (30) correctly engaged with keys (31). Keep the string taut and position the body of the travel motor on the body's side. Do not release the tension on the string at this time. Install barrel assembly (23) as a unit on the shaft. Pull the string out of the body of the travel motor. It may be necessary to pull the barrel assembly and the piston shoe assemblies away from the cam plate slightly in order to release the string.
-



---

Illustration 9

g00651967

18. Install O-ring seal (21) and backup ring (22) on piston guide (19), as shown.



---

Illustration 10

g00510356

19. Place the body of the travel motor in a vertical position.
  20. Apply clean hydraulic oil on five friction plates (20) and the four steel plates. Install the plates in alternating order in the body of the travel motor. Start with a friction plate and end with a friction plate.
  21. Install piston guide (19) in the body of the travel motor until the piston guide contacts the counterbore in the body of the travel motor.
-

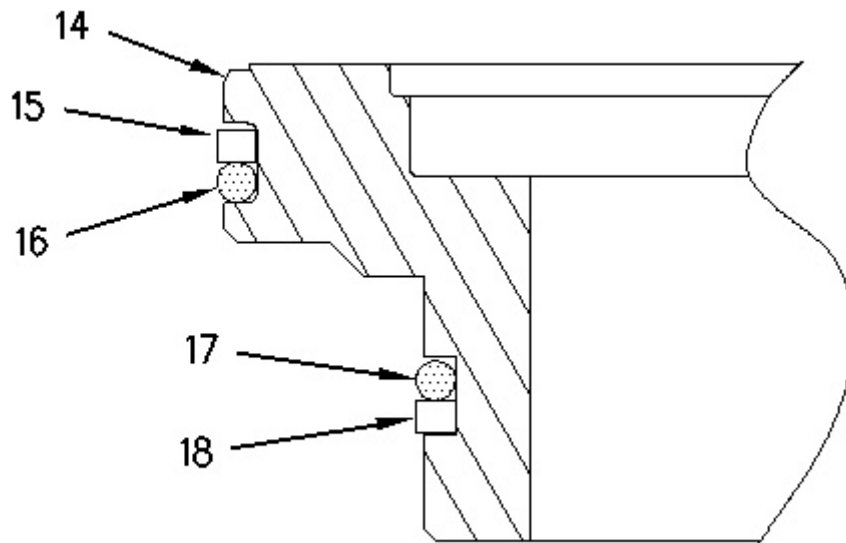

---

Illustration 11

g00878297

**Note:** Make sure that brake piston (14) is thoroughly clean and free of dirt and debris.

22. Install O-ring seal (16). Install backup ring (15).
  23. Install O-ring seal (17). Install backup ring (18).
  24. Apply a thin coat of hydraulic oil on the surfaces of brake piston (14) which contact the body of the travel motor. Install brake piston (14) in the body of the travel motor by hand. It may be necessary to use a soft faced hammer to seat the brake piston correctly.
- 

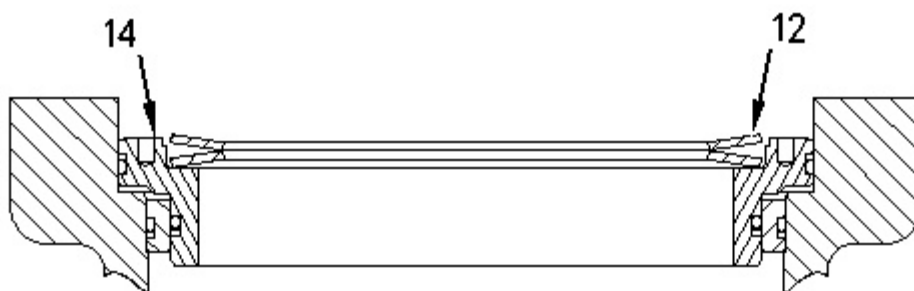

---

Illustration 12

g00878299

---



Illustration 13

g01000124

25. Install washer set (13) in piston (14), as shown.
26. Install O-ring seals (12) in the body of the travel motor, as shown.

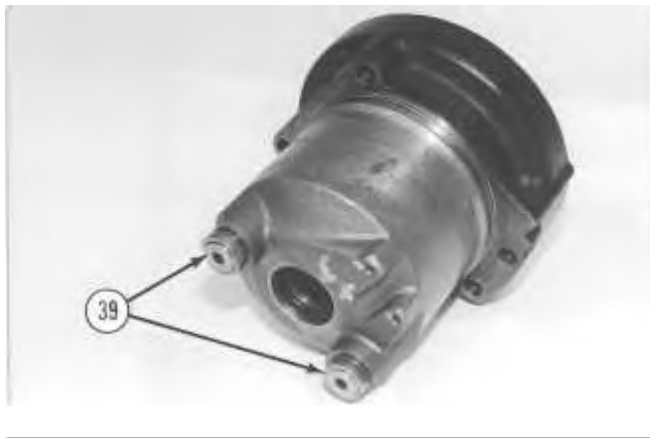

Illustration 14

g00510605

27. Install the two pistons and two stoppers (39) in the housing of the travel motor. Tighten the stoppers to a torque of  $140 \pm 14 \text{ N}\cdot\text{m}$  ( $105 \pm 10 \text{ lb ft}$ ).

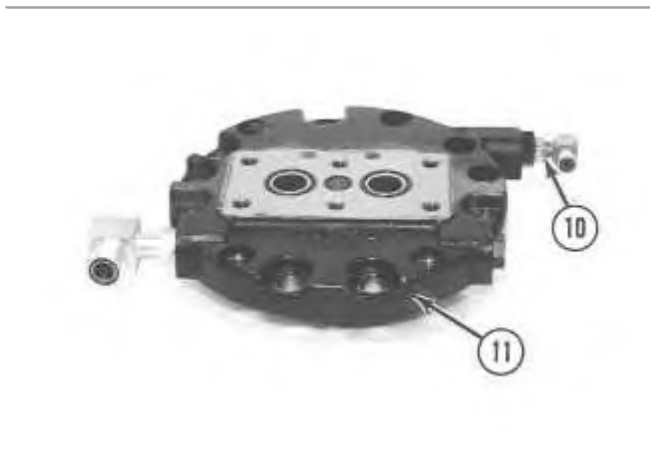

Illustration 15

g00510351

28. Install the O-ring seals on fittings (10). Use Tooling (D) on the threads of fittings (10). Install the fittings in the head, as shown.
29. Install plugs (11) in the head. Tighten each plug to a torque of  $15 \pm 2$  N·m ( $11 \pm 1$  lb ft).

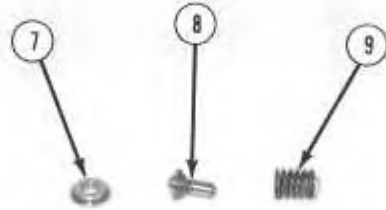

Illustration 16

g00510349

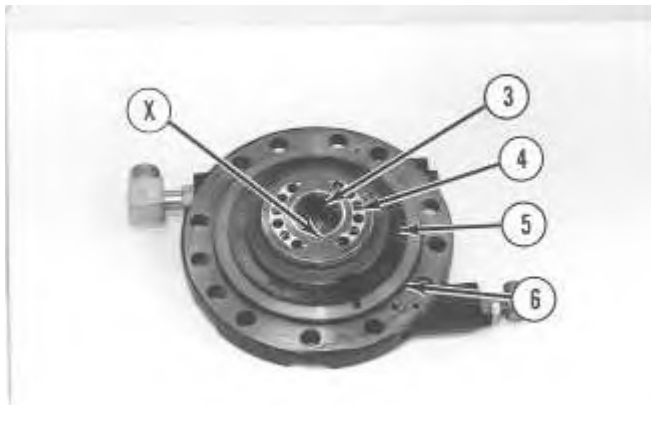

Illustration 17

g00510341

30. Use Tooling (E) on the threads of the check valves. Install the check valves in the head.
31. Install seat (7), poppet (8) and spring (9) in the head at Location (X).
32. Install O-ring seal (6) in the head, as shown.
33. Install bearing (3) in the head until the bearing contacts the counterbore in the cover.
34. Use Tooling (F) on port plate (4). Install the port plate in the port plate's original position on the motor cover.
35. Use a shim or shims (5) so that the following requirements are met.

**Note:** During the following checks, turn the travel motor output shaft in a clockwise direction.

- a. The travel motor output shaft does not rotate with an applied torque of  $440$  N·m ( $325$  lb ft) or more with the parking brake release port open.

- b. The travel motor output shaft rotates with an applied torque of 29 N·m (21 lb ft) or less when the parking brake release port is pressurized to 780 kPa (115 psi) with both the inlet port and the outlet port open to the hydraulic oil tank.

**Note:** It may be necessary to remove head (2) several times in order to determine the correct thickness of shim or shims (5) that are used to adjust the rolling torque of the travel motor output shaft.

36. Use Tooling (G) on shims (5). Install the shim or shims on the head. The grease will hold the shim or shims in place during the installation of the head. Install the head on the body of the travel motor.



Illustration 18

g00510326

37. Place head (2) in the head's original position on the travel motor. Install socket head bolts (1) that secure the head. Tighten the socket head bolts to a torque of  $175 \pm 18$  N·m ( $130 \pm 13$  lb ft).

---

## NOTICE

**To prevent possible damage to the travel motor, fill the unit with oil at least to the fill port before operating the machine. Refer to the Operation and Maintenance Manual for the correct oil specification.**

---

### End By:

- a. Install the travel motor. Refer to Disassembly and Assembly, "Travel Motor - Install" in this manual.

Previous Screen

Product: EXCAVATOR

Model: 325F LCR EXCAVATOR YCA

Configuration: 325F L Excavators YCA00001-UP (MACHINE) POWERED BY C4.4 Engine

**Disassembly and Assembly  
325F Excavator Machine Systems**

Media Number -UENR6794-05

Publication Date -01/09/2018

Date Updated -18/09/2018

i07181285

## Final Drive - Remove and Install

SMCS - 4050-010

### Removal Procedure

Table 1

Required Tools			
Tool	Part Number	Part Description	Qty
A	8S-7611	Handle As	2
	8S-7615	Pin As	2
	283-1495	Stand Assembly	2
B	439-3939	Link Bracket As	2
C	154-6184	Forcing Bolt (M 20)	2
D	-	Loctite C5A Copper Anti-Seize	-

**Start By:**

- a. Separate the track assembly.
- b. Remove the travel motor.

---



Illustration 1  
Typical Example

g00489826

**Note:** Adjust the height of Tooling (A) so that there is sufficient clearance between the sprocket and the track for the removal of the final drive.

1. Lift the side of the machine to install Tooling (A) under the frame, as shown.



Illustration 2  
Typical Example

g00712767

2. Fasten Tooling (B) and a suitable lifting device to final drive (1), as shown. Put a slight lifting tension on the final drive.

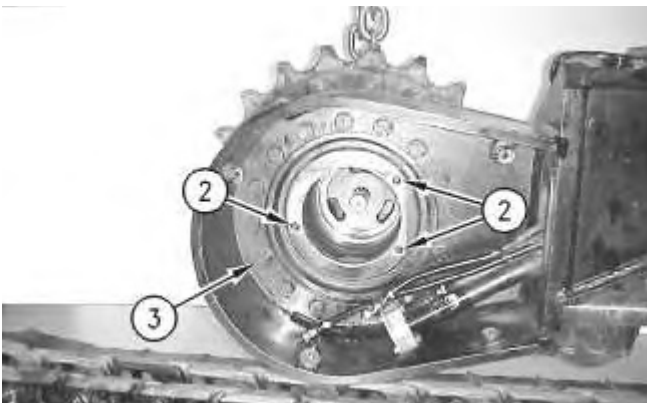

**Note:** Mark the orientation of bolt holes (2) for the travel motor for installation purposes.

3. Remove bolts (3) and the washers from the final drive.

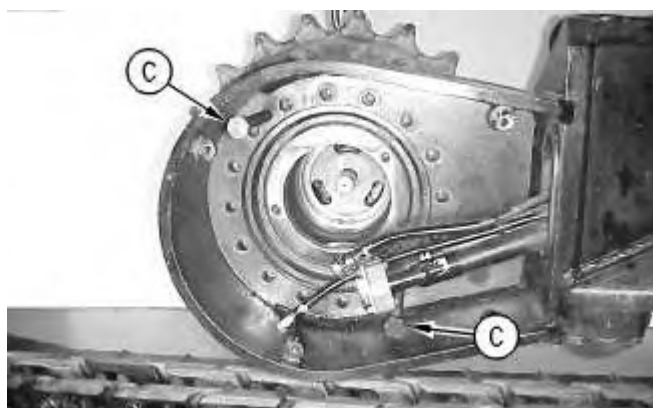

Illustration 4

4. Use Tooling (C) to remove the final drive from the frame.
5. Carefully remove final drive (1). The weight of final drive (1) and the sprocket is approximately 312 kg (688 lb).
6. Remove Tooling (C) from the frame.

## Installation Procedure

1. Install final drive (1) in the reverse order of removal.
  - a. Before assemble, remove all compounds, oil, and dust from the female threads washers
  - b. Apply Tooling (D) to the threads of bolts (3) and tighten to a torque of  $150 \pm 25$  N·m ( $111 \pm 18$  lb ft) and turn an additional angle of  $60 \pm 5$  degrees.
  - c. Refer to Service Magazine, M0083843, "An Improved Bolt Tightening Procedure for the Critical Joints Is Now Used On All Excavators" for more detail information.

[Previous Screen](#)

Product: EXCAVATOR

Model: 325F LCR EXCAVATOR YCA

Configuration: 325F L Excavators YCA00001-UP (MACHINE) POWERED BY C4.4 Engine

## Disassembly and Assembly 325F Excavator Machine Systems

Media Number -UENR6794-05

Publication Date -01/09/2018

Date Updated -18/09/2018

i06586042

# Final Drive - Disassemble

SMCS - 4050-015

## Disassembly Procedure

Table 1

Required Tools			
Tool	Part Number	Part Description	Qty
A	1P-2420	Transmission Repair Stand	1
B	439-3938	Link Bracket	2
C	154-6181	Forcing Bolt	1
D	439-3940	Link Bracket	2
E	5F-7366	Forcing Bolt	1
	1P-5546	Crossblock	1
	1U-9889	Crossblock	1
	1P-0520	Driver Group	1
	6V-7888	Puller Leg	2
	1H-3112	Puller Assembly	1
	1P-5551	Adjustable Screw Assembly	1
F	-	Loctite 5127	1

### Start By:

- a. Remove the final drive.

**Note:** Cleanliness is an important factor. Before the disassembly procedure, thoroughly clean the exterior of the component. This action will prevent dirt from entering the internal mechanism.

1. Put an alignment mark across the sections of the final drive for assembly purposes. The parts must be reinstalled in the original locations.



Illustration 1

g00708089

2. Fasten the final drive to Tooling (A), as shown. The combined weight of the final drive and final drive sprocket is approximately 312 kg (688 lb).
3. Remove bolts (1) and the washers that hold the cover in position.

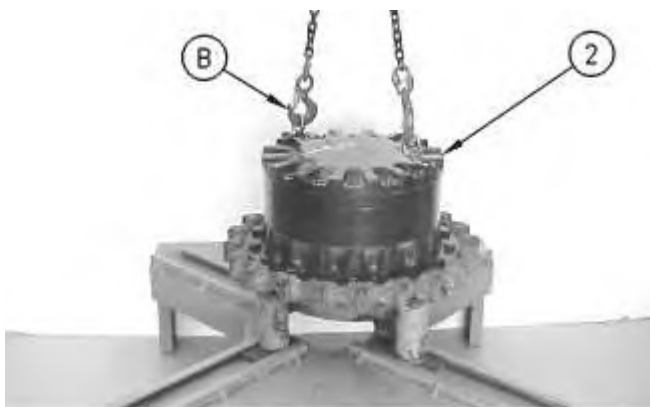

Illustration 2

g00708090

Typical Example

4. Remove the setscrews from cover (2), and fasten Tooling (B) and a suitable lifting device to cover (2), as shown. The weight of cover (2) is approximately 32 kg (70 lb). Remove cover (2).
-



**Suggest:**

**If the above button click is invalid.**

**Please download this document first, and then click the above link to download the complete manual.**

**Thank you so much for reading**

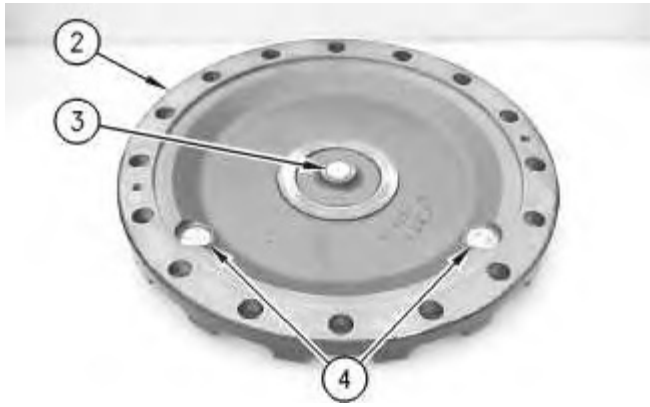

Illustration 3

g00708091

5. Remove thrust plate (3) from cover (2).
6. Remove plugs (4) from cover (2).

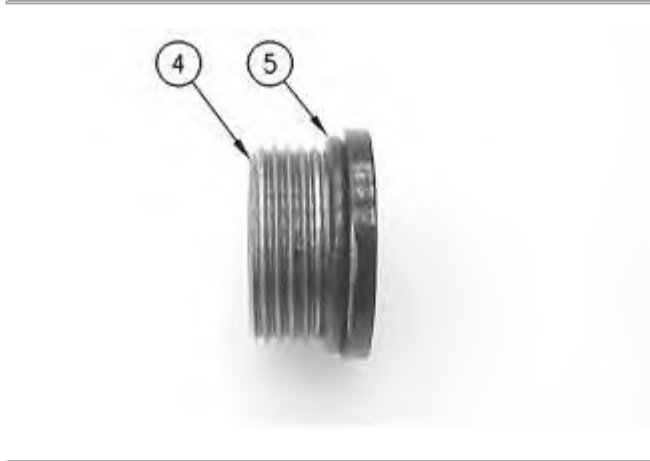

Illustration 4

g00708235

7. Remove O-ring seals (5) from both plugs (4) that were in the cover.

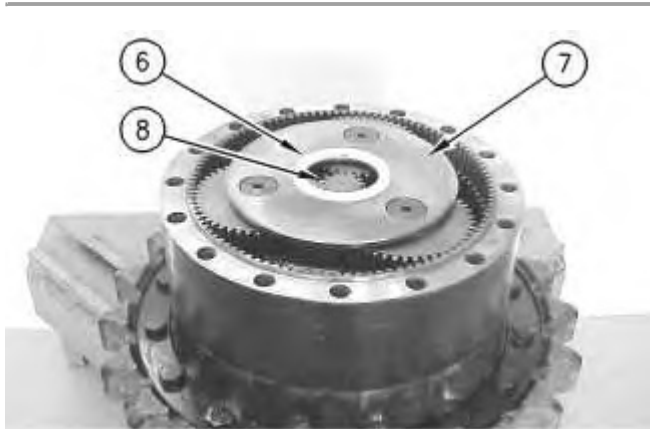

Illustration 5

g00708092

8. Remove spacer (6) from carrier assembly (7).
9. Remove sun gear (8) from carrier assembly (7).

**<https://www.ebooklibonline.com>**

Hello dear friend!

Thank you very much for reading.

Enter the link into your browser.

The full manual is available for immediate download.

**<https://www.ebooklibonline.com>**