



Service Repair Manual

Models

320D2 and 320D2 L Excavator

[Previous Screen](#)

Product: EXCAVATOR

Model: 320D2 EXCAVATOR DNP

Configuration: 320D2 & 320D2 L Excavators DNP00001-UP (MACHINE) POWERED BY C7.1 Engine

Disassembly and Assembly 320D2 Excavator Machine Systems

Media Number -UENR3252-09

Publication Date -01/07/2015

Date Updated -30/07/2018

i04262676

Swing Drive - Assemble

SMCS - 5459-016

S/N - DFM1-UP

S/N - DNP1-UP

S/N - EAL1-UP

S/N - EKT1-UP

S/N - ESG1-UP

S/N - FKK1-UP

S/N - GBA1-UP

S/N - HDM1-UP

S/N - JFM1-UP

S/N - KHR1-UP

S/N - LMA1-UP

S/N - NBT1-UP

S/N - RDZ1-10499

S/N - SDZ291-UP

S/N - STN1-10099

S/N - TGJ1-UP

S/N - TMF1-UP

S/N - WDJ1-UP

S/N - XAN1-UP

S/N - XBB1-UP

S/N - XCC1-UP

S/N - YEA1-UP

S/N - ZBD1-UP

S/N - ZCS1-UP

Assembly Procedure

Table 1

Required Tools			
Tool	Part Number	Part Description	Qty
A	5P-1863	Retaining Ring Pliers	1
B	138-7575	Link Brackets	2
D	138-7573	Link Brackets	2
E	FT-3023	Sleeve	1
G	1P-0520	Driver Gp	1
H	5P-3931	Anti-Seize Compound	1
J	8M-4856 ⁽¹⁾	Sleeve	1
K	-	Guide Stud M16 - 2.00 by 140mm	2
L	1U-8846	Gasket Sealant	1

⁽¹⁾ This part is being discontinued. Replace with **367-6742** Sleeve .

Note: Cleanliness is an important factor. Before assembly, clean all parts in cleaning fluid. Allow the parts to air dry. Wiping cloths or rags should not be used to dry parts. Lint may be deposited on the parts which may cause later trouble. Inspect all parts. If any parts are worn or damaged, use new parts for replacement.

<https://www.ebooklibonline.com>

Hello dear friend!

Thank you very much for reading.

Enter the link into your browser.

The full manual is available for immediate download.

<https://www.ebooklibonline.com>

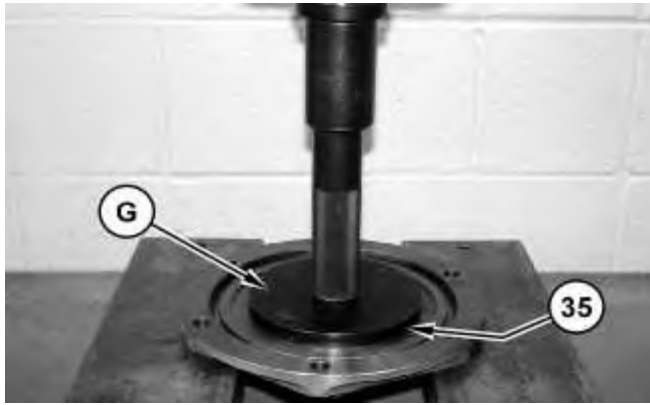

Illustration 1

g01339794

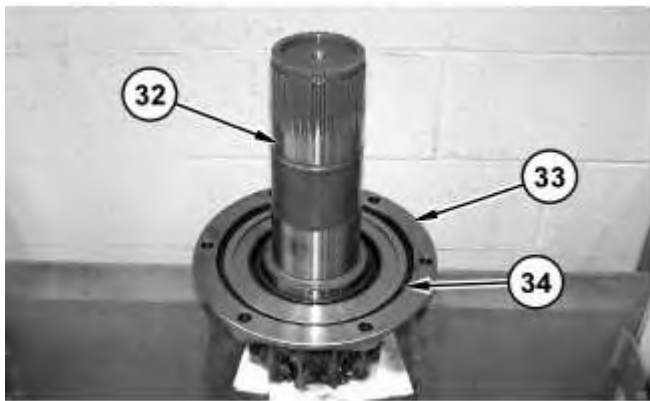

Illustration 2

g01339807

1. Use a suitable press and Tooling (G) in order to install lip seal (35) into cage (33).
2. Use two people to place shaft (32) in a suitable press. The weight of shaft (32) is approximately 30 kg (65 lb). Install cage (33). Install O-ring seal (34).

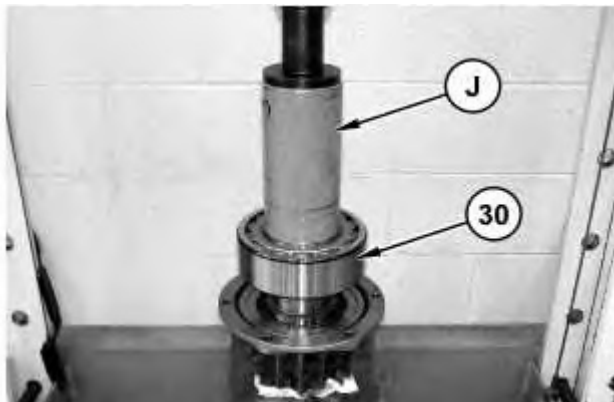

Illustration 3

g01339812

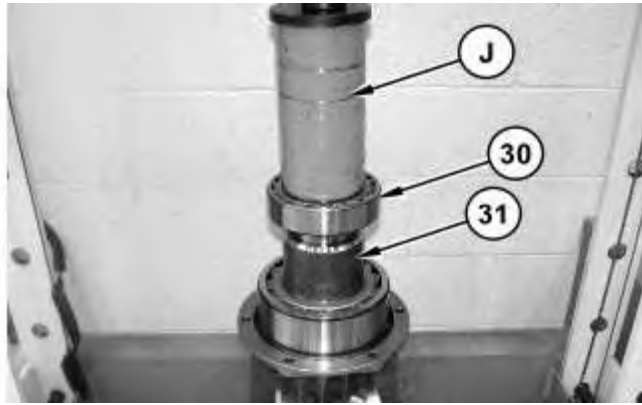

Illustration 4

g01339149

3. Apply Tooling (H) to inner diameter of the bearing and the shaft. Use a suitable press and Tooling (J) in order to install bearing (30). Install spacer (31). The bevel of the spacer must face upward.
4. Install bearing (30).

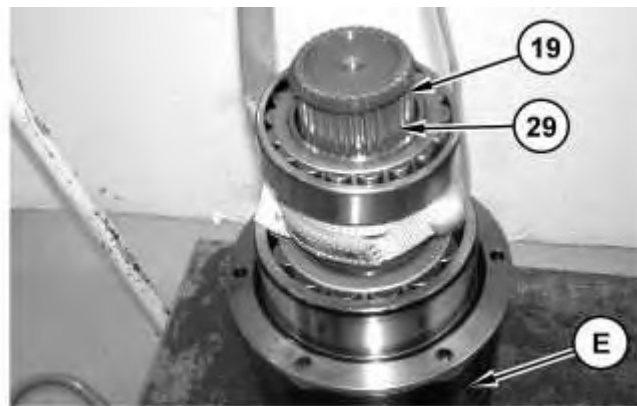

Illustration 5

g01339824



Illustration 6

g01339903

5. Attach a suitable lifting device to shaft assembly (29). Use Tooling (A) in order to install retaining ring (19). Install shaft assembly (29) onto Tooling (E). Remove the suitable lifting device.
6. Attach Tooling (B) and a suitable lifting device to housing (28). Install housing (28) on the shaft assembly. Position the shaft assembly to the side by 90 degrees. Remove tooling (E).



Illustration 7

g01339732

7. Install bolts (27).

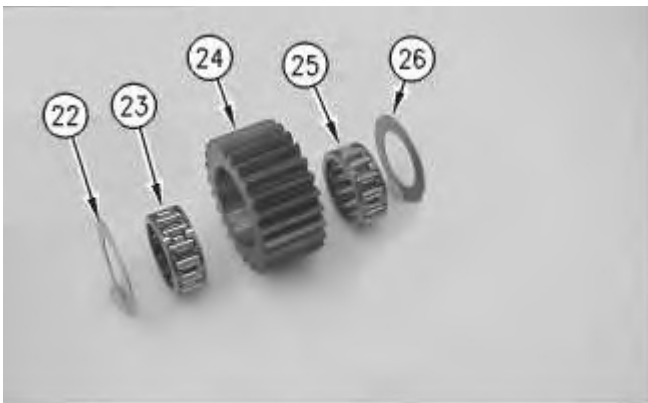
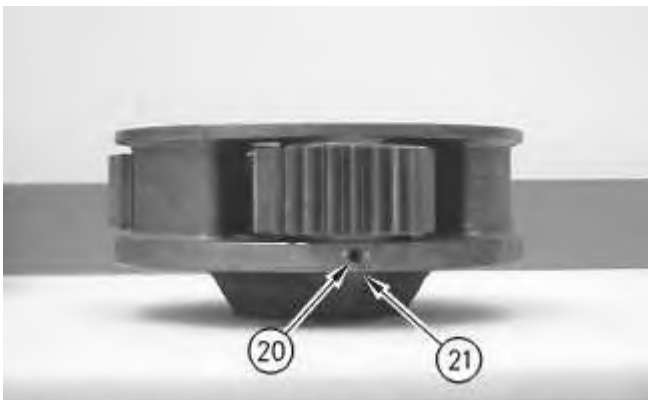
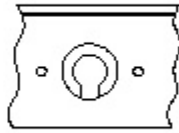

Illustration 8

g00703698

8. Assemble the gear assembly, as follows: washer (22), bearing (23), gear (24), bearing (25), and washer (26).





OR

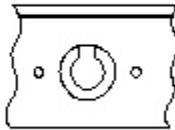

9. Use a deburring tool in order to remove the metal burr from the openings in the carrier. Install shaft (21) and the gear assembly into the carrier assembly. Drive roll pin (20) into shaft (21). Orient the split in roll pin (20) vertically to the carrier. Align the split in the roll pin to the top or to the bottom. Make a stake mark on each side of the roll pin hole in the carrier. Each stake mark should be approximately 2.25 ± 0.75 mm (0.090 ± 0.030 inch) from the outside diameter of the roll pin hole.
10. Repeat Step 8 through Step 9 for the remaining gear assemblies.

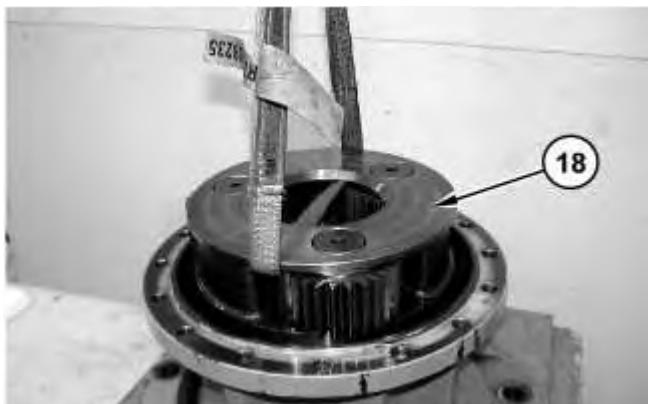

11. Install carrier assembly (18) into the housing. The weight of carrier assembly (18) is approximately 25 kg (55 lb).
-

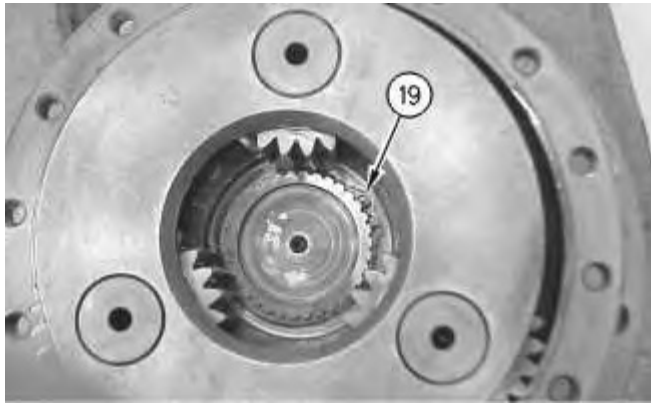

Illustration 12

g00702596

12. Use Tooling (A) to install retaining ring (19).

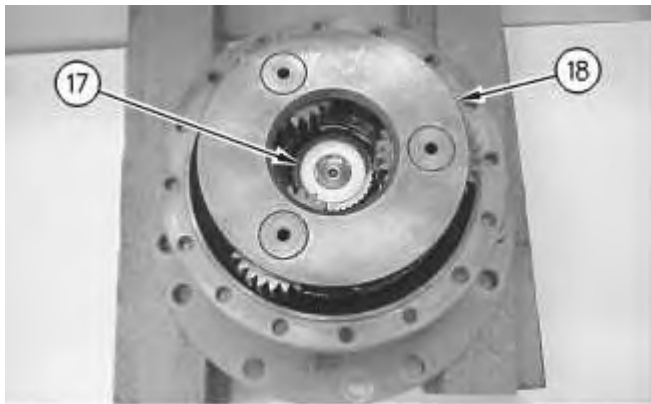

Illustration 13

g00702584

13. Install spacer (17) into carrier assembly (18).

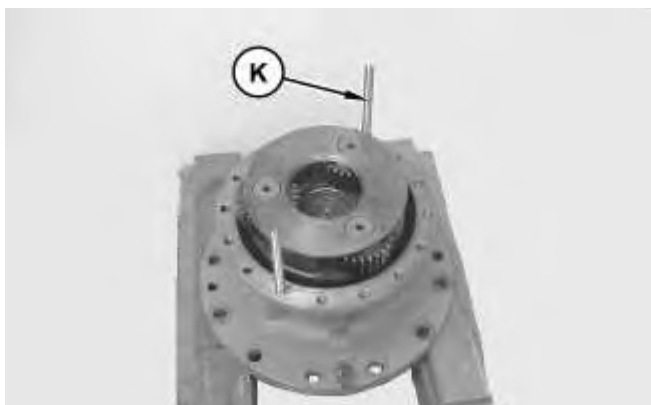

Illustration 14

g01340279

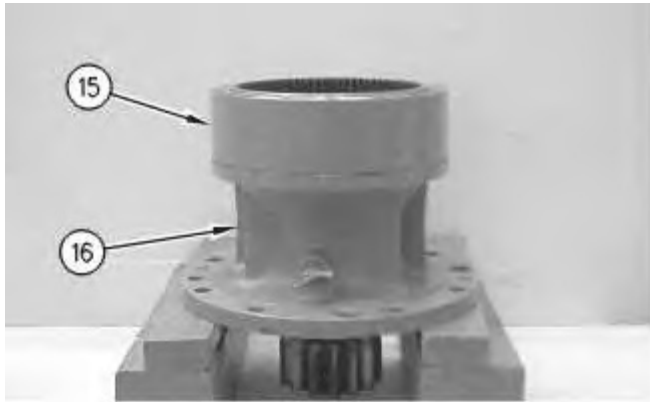

Illustration 15

g00702583

14. Apply Tooling (L) to the face of housing (16). Install Tooling (K) in order to help align the housing and the ring gear. Use two people in order to install ring gear (15) onto housing (16). The weight of ring gear (15) is approximately 29 kg (65 lb).



Illustration 16

g00702459

15. Install retaining ring (14) into the sun gear.

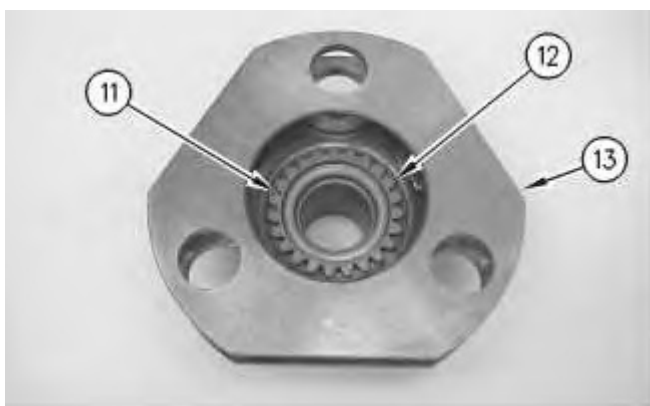

Illustration 17

g00702457

16. Install carrier (13) into the sun gear. Install retaining ring (11) into sun gear (12).

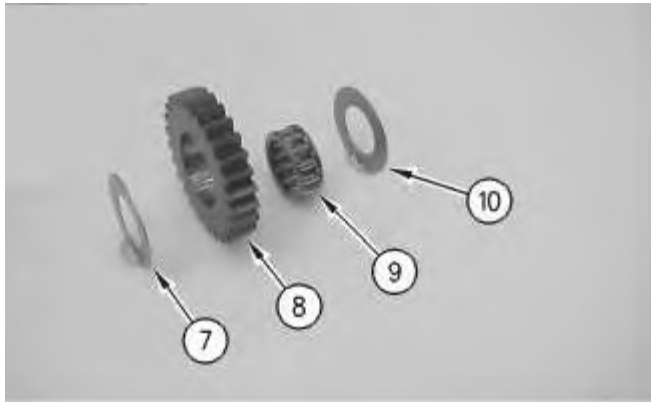

Illustration 18

g00703707

17. Assemble the gear assembly, as follows: washer (7), gear (8), bearing (9), and washer (10)

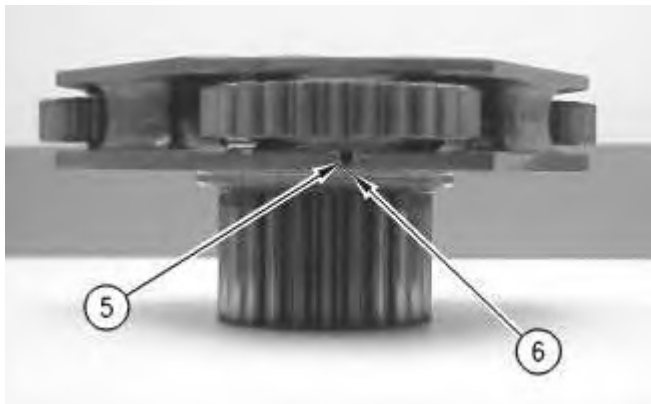
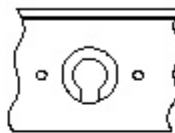

Illustration 19

g00702452



OR

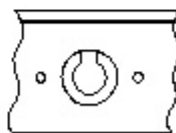

Illustration 20

g00703700

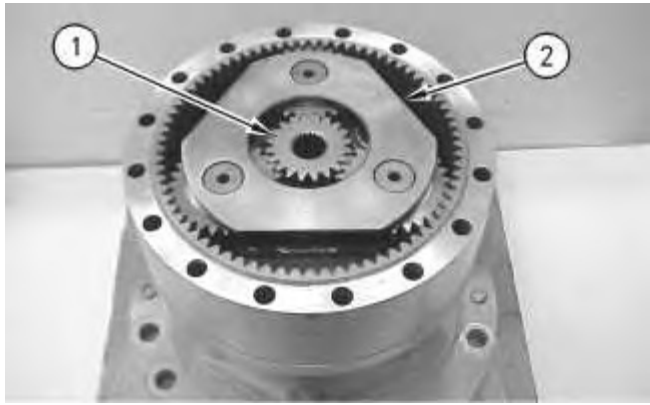

Illustration 23

g00702449

22. Install sun gear (1) into carrier assembly (2).

End By:

- a. Install the swing motor and swing drive. Refer to Disassembly and Assembly, "Swing Motor and Swing Drive - Install".

[Previous Screen](#)

Product: EXCAVATOR

Model: 320D2 EXCAVATOR DNP

Configuration: 320D2 & 320D2 L Excavators DNP00001-UP (MACHINE) POWERED BY C7.1 Engine

Disassembly and Assembly 320D2 Excavator Machine Systems

Media Number -UENR3252-09

Publication Date -01/07/2015

Date Updated -30/07/2018

i02386587

Swing Gear and Bearing - Remove

SMCS - 7063-011

S/N - DFM1-UP

S/N - DNP1-UP

S/N - EAL1-UP

S/N - EKT1-UP

S/N - ESG1-UP

S/N - FKK1-UP

S/N - GBA1-UP

S/N - HDM1-UP

S/N - JFM1-UP

S/N - KHR1-UP

S/N - LMA1-UP

S/N - NBT1-UP

S/N - RDZ1-UP

S/N - SDZ291-UP

S/N - STN1-UP

S/N - TGJ1-UP

S/N - TMF1-UP

S/N - WDJ1-UP

S/N - XAN1-UP

S/N - XBB1-UP

S/N - XCC1-UP

S/N - YEA1-UP

S/N - ZBD1-UP

S/N - ZCS1-UP

Removal Procedure

Table 1

Required Tools			
Tool	Part Number	Part Description	Qty
A	138-7576	Link Bracket	4
B	132-8223	Hydraulic Pump and Motor (115 V 50/60 Hz Single Phase) ⁽¹⁾	1
	1U-6221	Hydraulic Torque Wrench	1
	132-8143	36 mm Hex Link	1

⁽¹⁾ 132-8231 Hydraulic Pump and Motor (220 V 50/60 Hz Single Phase) is also available.

Start By:

- a. Remove the undercarriage frame. Refer to Disassembly and Assembly, "Upper Frame and Undercarriage Frame - Separate".
1. Remove all of the grease from the swing gear and bearing. Put the grease in a suitable container for storage or disposal.



- Put an alignment mark on swing gear and bearing (1) and on the undercarriage frame assembly for assembly purposes. Attach Tooling (A) and a suitable lifting device to swing gear and bearing (1), as shown. Apply slight lifting tension to the swing gear and bearing.

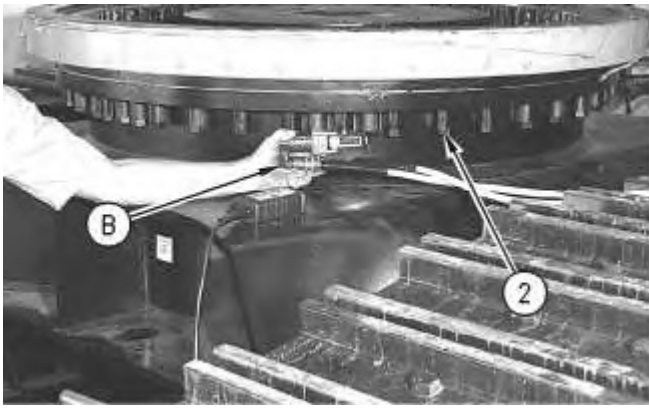

Illustration 2

- Use Tooling (B) in order to remove bolts (2) and the spacers that hold swing gear and bearing (1) to the undercarriage frame.
- Remove swing gear and bearing (1). The weight of the swing gear and bearing (1) is approximately 280 kg (615 lb).

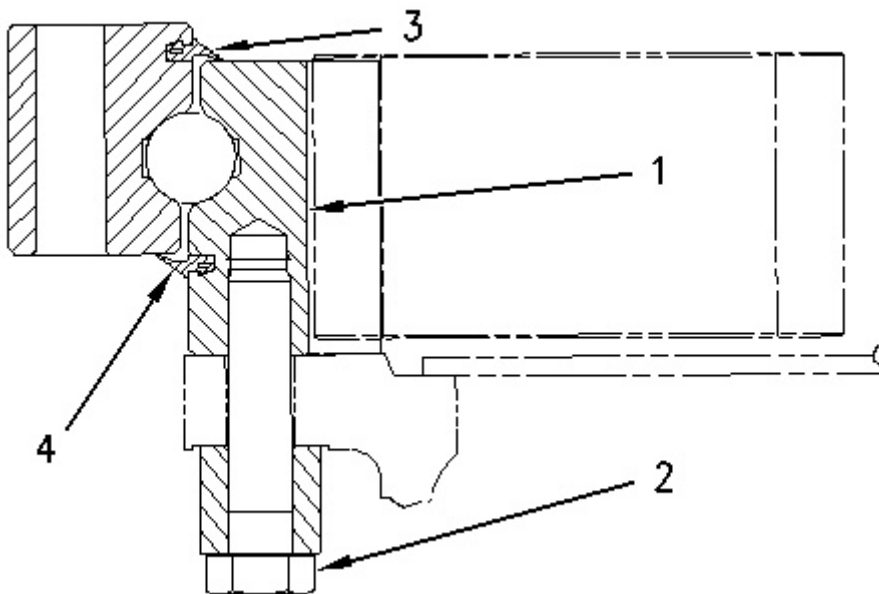

Illustration 3

Note: Inner dust seal (3) and outer dust seal (4) may have been installed dry in the swing gear and bearing or inner dust seal (3) and outer dust seal (4) may have been bonded to the swing gear and bearing.

- Remove inner dust seal (3) and outer dust seal (4) from the swing gear and bearing.

6. Clean the seal grooves of the inner dust seal and the outer dust seal with a fine grit sandpaper. Use a cleaning solvent to clean the sealing grooves. Make sure that the seal grooves are thoroughly clean and dry prior to installing the new dust seals.

[Previous Screen](#)

Product: EXCAVATOR

Model: 320D2 EXCAVATOR DNP

Configuration: 320D2 & 320D2 L Excavators DNP00001-UP (MACHINE) POWERED BY C7.1 Engine

Disassembly and Assembly 320D2 Excavator Machine Systems

Media Number -UENR3252-09

Publication Date -01/07/2015

Date Updated -30/07/2018

i07430284

Swing Gear and Bearing - Install

SMCS - 7063-012

S/N - DFM1-UP

S/N - DNP1-UP

S/N - EAL1-UP

S/N - EKT1-UP

S/N - ESG1-UP

S/N - FKK1-UP

S/N - GBA1-UP

S/N - HDM1-UP

S/N - JFM1-UP

S/N - KHR1-UP

S/N - LMA1-UP

S/N - NBT1-UP

S/N - RDZ1-UP

S/N - SDZ291-UP

S/N - STN1-UP

S/N - TGJ1-UP

S/N - TMF1-UP

S/N - WDJ1-UP

S/N - XAN1-UP

S/N - XBB1-UP

S/N - XCC1-UP

S/N - YEA1-UP

S/N - ZBD1-UP

S/N - ZCS1-UP

Installation Procedure

Table 1

Required Tools			
Tool	Part Number	Part Description	Qty
A	138-7576	Link Bracket	4
B	132-8223	Hydraulic Pump and Motor (115 V 50/60 Hz Single Phase) ⁽¹⁾	1
	1U-6221	Hydraulic Torque Wrench	1
	132-8143	36 mm Hex Link	1
C	-	Loctite 435	-
D	2P-9066	Lubricant	1
E	1U-8846	Gasket Sealant	1
F	4C-5599	Anti-Seize Compound	1

⁽¹⁾ 132-8231 Hydraulic Pump and Motor (220 V 50/60 Hz Single Phase) is also available.

Note: If the inner dust seal (3) and the outer dust seal (4) were installed dry, the new dust seals should be installed dry in the swing gear and bearing.

Note: If the dust seal were bonded to the swing gear and bearing, the new dust seals should be bonded to the swing gear and bearing.

Note: Perform Steps 1.a through 1.j to install the new dry dust seals.

Note: Perform Steps 2.a through 2.p to install the new dust seals that are bonded to the swing gear and bearing.

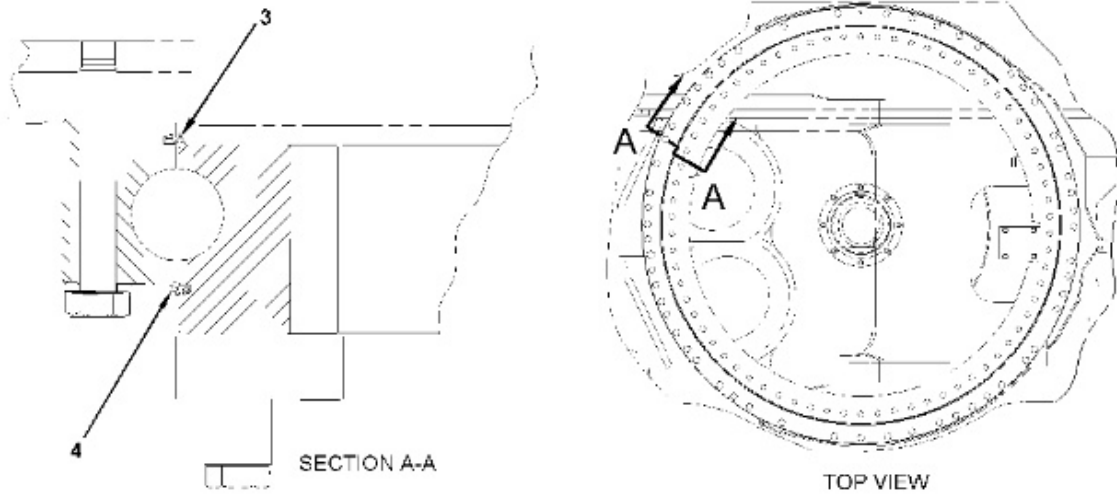

Illustration 1

g06320672

1. If inner dust seal (3) and outer dust seal (4) were installed dry, use the following procedure to install the new dust seals:
 - a. Use a wire brush to clean the grooves for the dust seal of the swing gear and bearing. Make sure that all the dirt and foreign material has been removed.
 - b. Wash the grooves for the dust seal in a suitable solvent that will not leave an oily residue.
 - c. Ensure that the grooves for the dust seal in the swing gear and bearing are clean and dry prior to installation of the dust seals.
 - d. Cut one end of inner dust seal (3) at a 90 degree angle. Use a blunt tool to install the inner dust seal in the seal groove of the swing gear and bearing.
 - e. Install the seal so that the lip of the seal is facing in the direction that is shown. Refer to Illustration 1.
 - f. After the inner dust seal is installed in the seal groove, measure the seal and cut the remaining end of the inner dust seal at a 90 degree angle. Install the remaining end of the inner dust seal in the seal groove.
 - g. Make sure that the inner dust seal is seated properly in the seal groove, all the way around the swing gear and bearing. Also, make sure that there is no gap between the ends of the inner dust seal.
 - h. Pull each end of the inner dust seal out of the seal groove of the swing gear and bearing approximately 50.8 mm (2.00 inch). Apply Tooling (C) to each end of the inner dust seal to bond the seals together.
 - i. Immediately reinstall the inner dust seal in the seal groove of the swing gear and bearing. Again, make sure that the entire inner dust seal is properly seated in the seal groove of the swing gear and bearing. No gap should exist between the ends of the inner dust seal.
 - j. To ensure that the lip of inner dust seal has not adhered to the top of the bearing at the seal joint, run a dull putty knife between the lip of the seal and the bearing at the seal joint.
 - k. Follow the procedure in Steps 1.a through 1.j to install outer dust seal (4) in the swing gear and bearing. Refer to Illustration 1 for proper seal orientation in the swing gear and bearing.

2. If inner dust seal (3) and outer dust seal (4) were bonded in the swing gear and bearing, use the following procedure to install the new dust seals:

- a. Thoroughly clean all the dirt and foreign material from the grooves for the dust seal in the swing gear and bearing with a wire brush.
- b. Wash the grooves for the dust seal in a suitable solvent that will not leave an oily residue.
- c. Make sure that the grooves for the dust seals in the swing gear and bearing are thoroughly clean and dry prior to installation of the dust seals.

Note: Install inner dust seal (3) and outer dust seal (4) in the swing gear and bearing in small increments, because Tooling (C) cures quickly.

- d. Cut one end of inner dust seal (3) at a 90 degree angle.
- e. Start applying Tooling (C) 50.8 mm (2.00 inch) from the cut end of the seal. Apply Tooling (C) to the seal in 152.4 mm (6.00 inch) increments.
- f. Immediately use a blunt tool to install only the bonded portion of the inner dust seal in the seal groove of the swing gear and bearing. Make sure that the dust seal is seated properly in the seal groove.
- g. Install the seal so that the lip of the seal is facing in the direction that is shown. Refer to Illustration 1.
- h. To ensure that the inner dust seal has not adhered to the bearing, run a dull putty knife between the lip of the seal and the bearing.
- i. Apply Tooling (C) to the next 152.4 mm (6.00 inch) of the seal. Immediately use a blunt tool to install only the bonded portion of the inner dust seal in the seal groove of the swing gear and bearing.
- j. Make sure that the inner dust seal is seated properly in the seal groove. To ensure that the inner dust seal has not adhered to the bearing, run a dull putty knife between the lip of the seal and the bearing.
- k. Repeat Step 2.i and Step 2.j to install the entire length of the dust seal. Do not install the last 152.4 mm (6.00 inch) of the inner dust seal.
- l. Measure the inner dust seal and cut the remaining end of inner dust seal (3) at a 90 degree angle. Install the last 152.4 mm (6.00 inch) of seal in the seal groove dry.
- m. Make sure that the inner dust seal is properly seated in the seal groove and that there is no gap between the seal ends. Carefully remove both loose ends of the inner dust seal out of the seal groove.
- n. Apply Tooling (C) to the loose ends of the seal.
- o. Immediately use a blunt tool to reinstall the seal ends in the seal groove. Again, make sure that the inner dust seal is properly seated in the seal groove. Make sure that no gap existed between the ends of the seal.
- p. To ensure that the inner dust seal has not adhered to the top of the bearing, run a dull putty knife around the seal.
- q. Follow the procedure in Steps 2.a through 2.p to install outer dust seal (4) in the swing gear and bearing. Refer to Illustration 1 for proper seal orientation in the swing gear and bearing.

3. Lubricate the swing gear and bearing with grease.



Illustration 2

g00520664

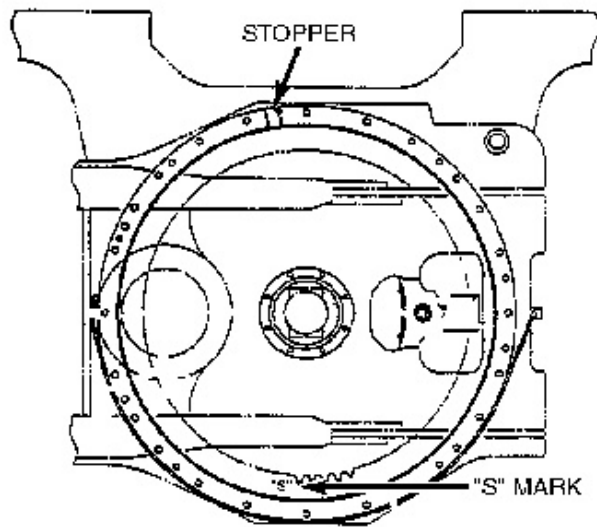

Illustration 3

g00520674

Note: Clean the mating surface for the swing gear and bearing on the undercarriage frame assembly.

4. Apply Tooling (E) on the mating surface for the swing gear and bearing of the undercarriage frame assembly.
 5. Fasten Tooling (A) and a suitable lifting device to swing gear and bearing (1), as shown. Refer to Illustration 2. The weight of swing gear and bearing (1) is 495 kg (1091 lb).
 6. Place the swing gear and bearing into the original positions on the undercarriage frame assembly.
 7. Make sure that the Stamp "S" on the inner race is in the position that is shown, relative to the undercarriage frame assembly and the stopper on the outer race. Refer to Illustration 3.
-

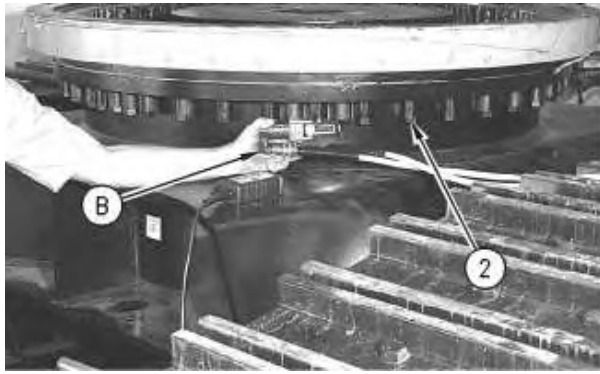

Illustration 4

g00520670

8. Apply a thin coat of Tooling (F) on the threads of bolts (2). Install the spacers and bolts (2) that secure the swing gear and bearing to the undercarriage frame assembly.

Note: Some machines use bolts that are plated with Dacromet. Dacromet bolts appear silver, gray in color. Do not apply Tooling (F) to the threads of Dacromet bolts. Make sure that the bolt holes are clean and dry when Dacromet bolts are used.

9. Use Tooling (B) to tighten bolts (2) to a torque of 568 ± 59 N·m (419 ± 44 lb ft).

NOTICE

Improper lubrication can cause damage to machine components.

To avoid damage, make sure that the proper amount of grease is applied to the swing drive.

When the amount of grease in the compartment becomes too large, the agitation loss becomes large, thereby accelerating grease deterioration.

Grease deterioration can cause damage to the pinion gear of the swing drive and swing internal gear.

Not enough grease will result in poor gear lubrication.

10. Add Tooling (D) to the swing gear and bearing after the installation . Refer to Operation and Maintenance Manual, "Swing Gear - Lubricate" and Operation and Maintenance Manual, "Swing Bearing - Lubricate" for lubricating the swing gear and bearing.

End By:

- a. Install the undercarriage frame assembly. Refer to Disassembly and Assembly, "Undercarriage Frame - Install".

[Previous Screen](#)

Product: EXCAVATOR

Model: 320D2 EXCAVATOR DNP

Configuration: 320D2 & 320D2 L Excavators DNP00001-UP (MACHINE) POWERED BY C7.1 Engine

Disassembly and Assembly 320D2 Excavator Machine Systems

Media Number -UENR3252-09

Publication Date -01/07/2015

Date Updated -30/07/2018

i02607531

Oil Filter (Hydraulic, Return) - Remove

SMCS - 5068-011

S/N - DFM1-UP

S/N - DNP1-UP

S/N - EAL1-UP

S/N - EKT1-UP

S/N - ESG1-UP

S/N - FKK1-UP

S/N - GBA1-UP

S/N - HDM1-UP

S/N - JFM1-UP

S/N - KHR1-UP

S/N - LMA1-UP

S/N - NBT1-UP

S/N - RDZ1-UP

S/N - SDZ291-UP

S/N - STN1-UP

S/N - TGJ1-UP

S/N - TMF1-UP

S/N - WDJ1-UP

S/N - XAN1-UP

S/N - XBB1-UP

S/N - XCC1-UP

S/N - YEA1-UP

S/N - ZBD1-UP

S/N - ZCS1-UP

Removal Procedure

Table 1

Required Tools			
Tool	Part Number	Part Description	Qty
A	138-7575	Link Bracket	2

1. Drain the hydraulic oil into a suitable container for storage or disposal. Refer to Operation and Maintenance Manual, "Hydraulic Oil - Change".

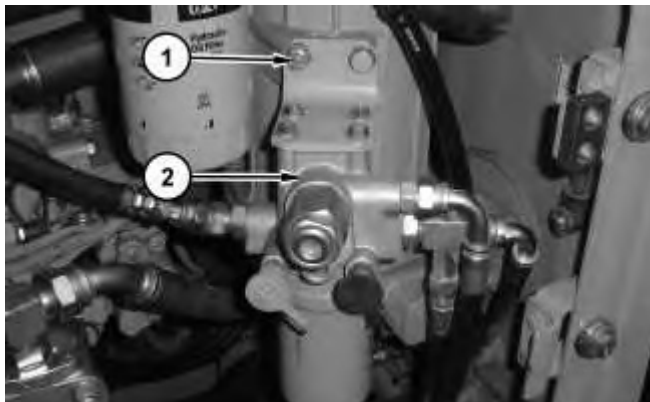

Illustration 1

g01218778

2. Remove bolts (1) and reposition filter assembly (2).



Suggest:

If the above button click is invalid.

Please download this document

first, and then click the above link

to download the complete manual.

Thank you so much for reading

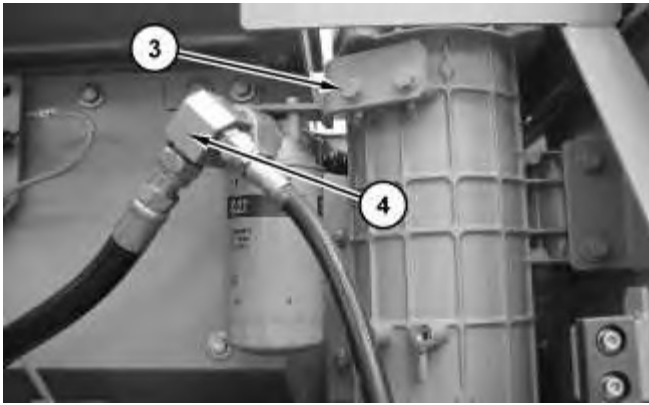

Illustration 2

g01305477

3. Remove bolts (3). Reposition filter assembly (4) out of the way.

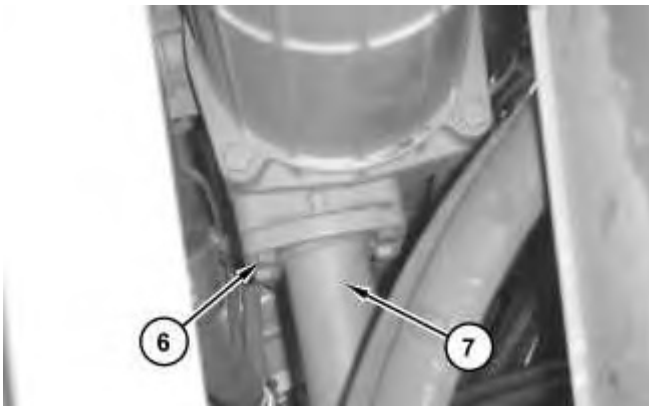

Illustration 3

g01218927

4. Remove bolts (6) from tube assembly (7).

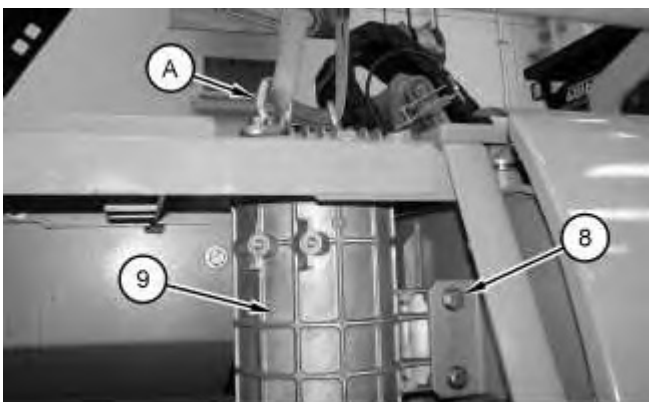

Illustration 4

g01218952

<https://www.ebooklibonline.com>

Hello dear friend!

Thank you very much for reading.

Enter the link into your browser.

The full manual is available for immediate download.

<https://www.ebooklibonline.com>