



Service Repair Manual

Models

304D CR Mini Excavator

[Previous Screen](#)

Product: MINI HYD EXCAVATOR

Model: 304D CR MINI HYD EXCAVATOR TYK

Configuration: 304D CR Mini Excavator TYK00001-UP (MACHINE) POWERED BY S3Q2 Engine

Disassembly and Assembly S3Q2 and S3Q2-T Engines

Media Number -KENR6786-03

Publication Date -01/08/2015

Date Updated -18/08/2015

i04111938

Timing Gear, Camshaft, and Oil Pan - Disassemble and Inspect

SMCS - 1206-015; 1206-040; 1210-015; 1210-040; 1302-015; 1302-040

Disassembling and inspecting timing gear, camshaft, and oil pan

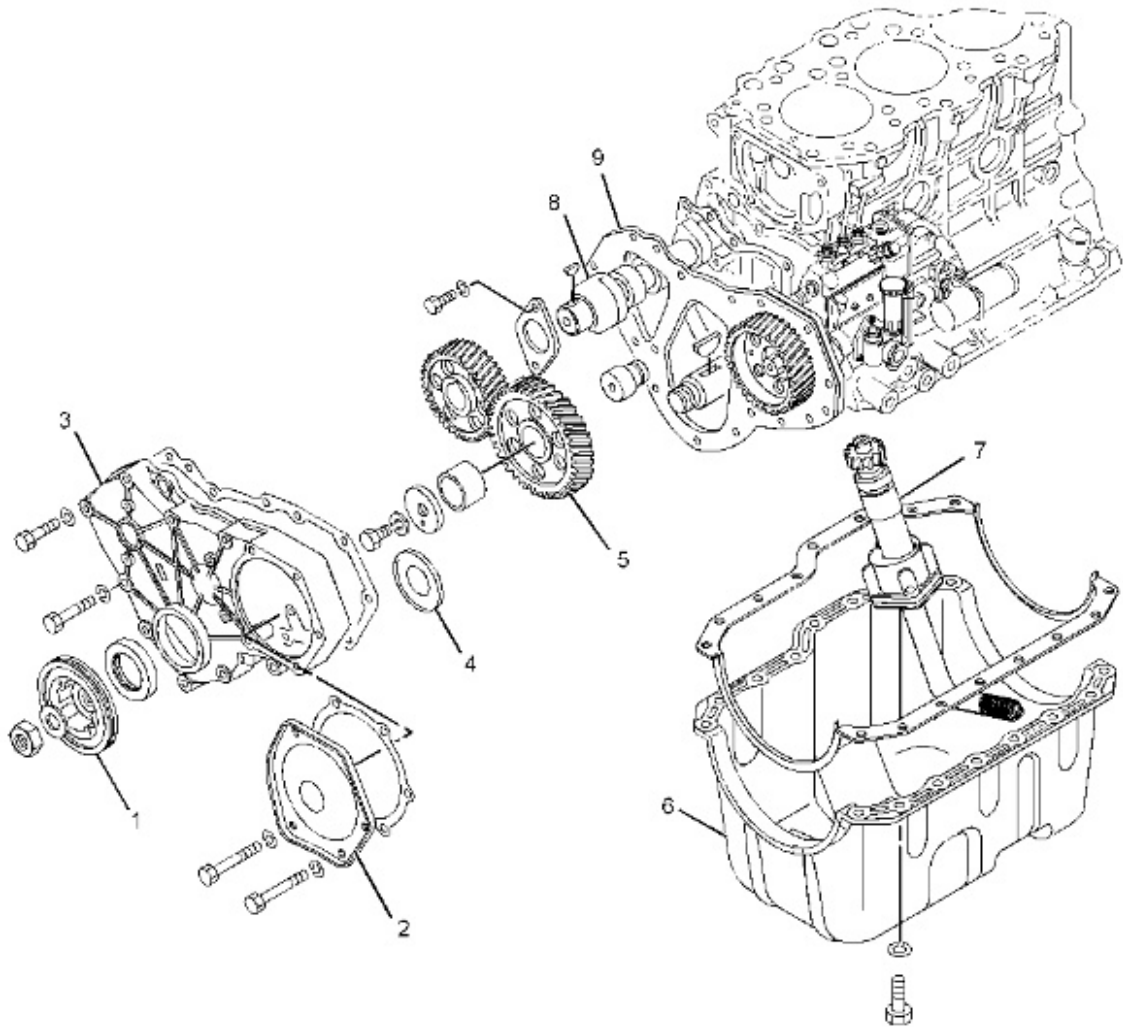

Illustration 1

g02315293

Disassembling sequence

- (1) Crankshaft pulley
- (2) Cover
- (3) Timing gear case
- (4) Baffle plate
- (5) Idler gear
- (6) Oil pan
- (7) Oil pump
- (8) Camshaft
- (9) Front plate

Removing crankshaft pulley

Note: The bar that stops the crankshaft from turning may come off. Pay due attention to safety.

<https://www.ebooklibonline.com>

Hello dear friend!

Thank you very much for reading.

Enter the link into your browser.

The full manual is available for immediate download.

<https://www.ebooklibonline.com>

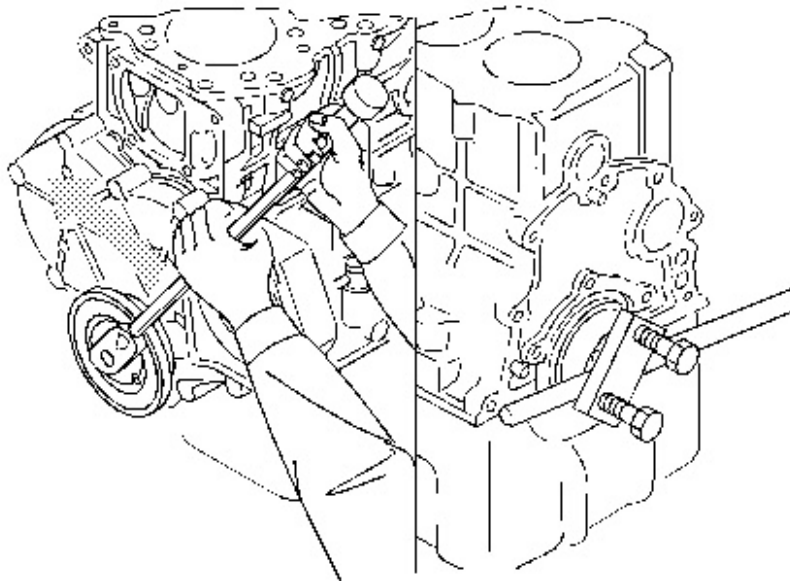

Illustration 2

g02210558

1. Screw two guide bolts into the threaded holes at the rear end of the crankshaft. Stick a bar across the guide bolts to prevent the crankshaft from turning.
2. Remove the crankshaft pulley.
3. Take out the woodruff key of the crankshaft.

Inspect the crankshaft pulley (1) for worn belt groove and worn oil seal contact surface.

Removing timing gear case

Note: The front plate is bolted to the crankcase from inside the gear case. Do not attempt to remove the front plate together with the gear case by tapping.

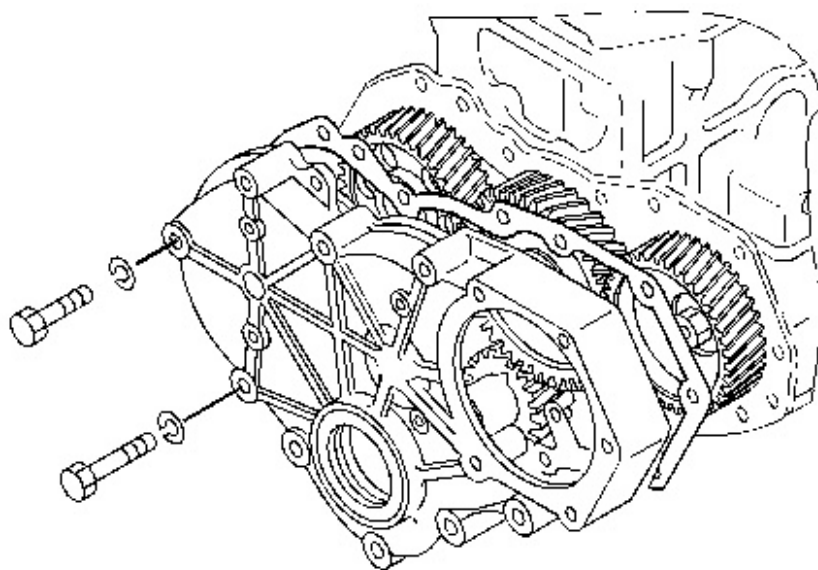

Illustration 3

g02210559

1. Remove bolts from the timing gear case.
2. Remove the timing gear case.

Inspect the timing gear case (3) for Crack and abnormality of knock hole.

Note: Bolts have different lengths. Pay attention to the positions of bolts to ensure correct reassembling.

Measuring timing gear backlash

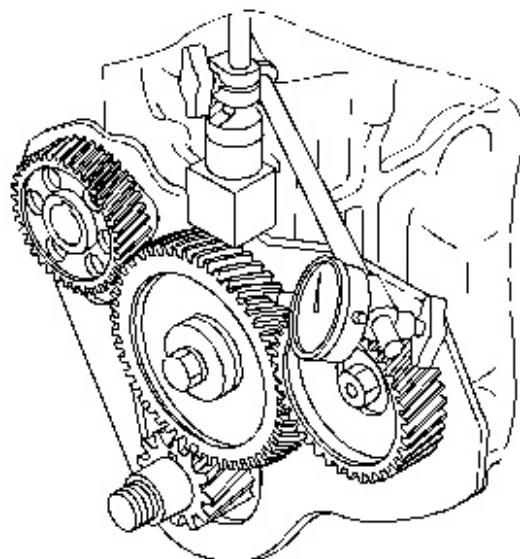

Illustration 4

g02210560

Use anyone of the following procedure to measure the backlash of the gear :

- Apply a dial gauge to the circumference of gear shaft at the right angle to the shaft.
- Insert feeler gauges into the meshing between two gears.

Replace the gear if the limit is exceeded.

Table 1

Item		Standard	Limit
Timing gear backlash	Between crankshaft gear and idler gear	0.030 to 0.160 mm (0.0012 to 0.0063 inch)	0.250 mm (0.0098 inch)
	Between idler gear and valve camshaft gear	0.040 to 0.170 mm (0.0016 to 0.0067 inch)	
	Between idler gear and pump camshaft gear	0.030 to 0.180 mm (0.0012 to 0.0071 inch)	

Measuring idler gear end play

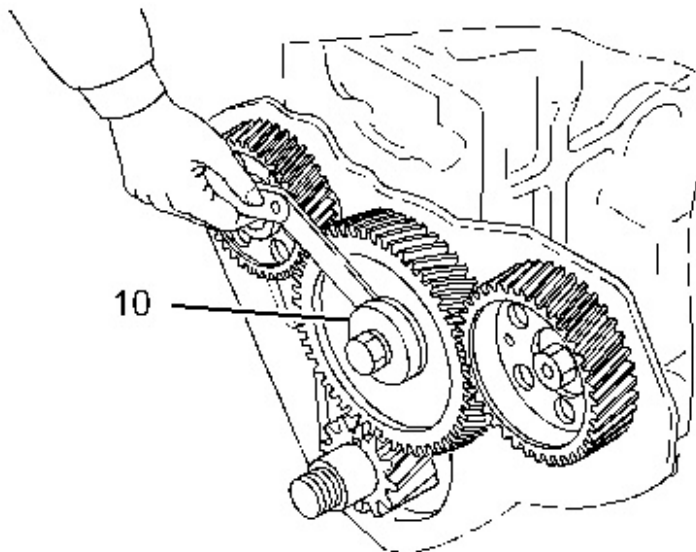

Illustration 5

g02210573

(10) Thrust plate

Using a feeler gauge or dial gauge, measure the end play of idler gear. If the measured value exceeds the limit, replace the idler gear with the new gear.

Table 2

Item	Standard	Limit

End play	0.050 to 0.200 mm (0.0020 to 0.0079 inch)	0.350 mm (0.0138 inch)
----------	---	------------------------

Removing idler gear

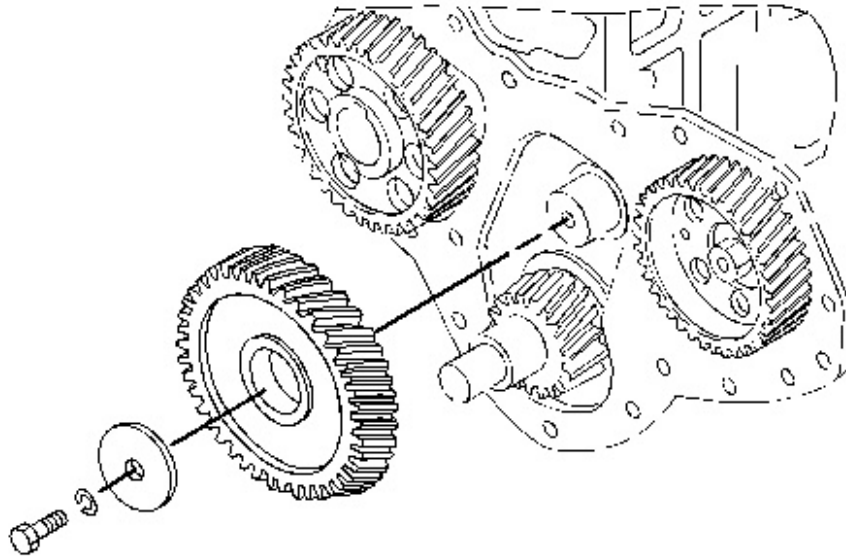

Illustration 6

g02210574

1. Remove the thrust plate bolt.
2. Remove the idler gear while turning the gear.

Inspect the thrust plate and idler gear bushing for wear. Inspect the idler gear for flaking, uneven contact, damage, and abnormal key groove condition. Inspect the plug for clogged oil holes and wear.

Measuring camshaft end play

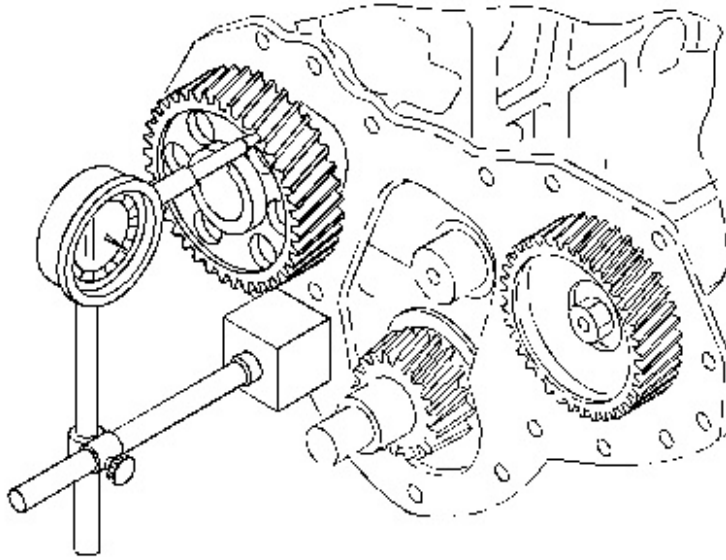

Illustration 7

g02210575

Measure the camshaft end play with the camshaft gear attached. If the limit is exceeded, replace the thrust plate with a new one.

Table 3

Item	Standard	Limit
Camshaft end play	0.100 to 0.250 mm (0.0039 to 0.0098 inch)	0.300 mm (0.0118 inch)

Inverting crankcase

Note: Do not place the engine directly on the ground, which leads damage / cracking of oil pan (6) .

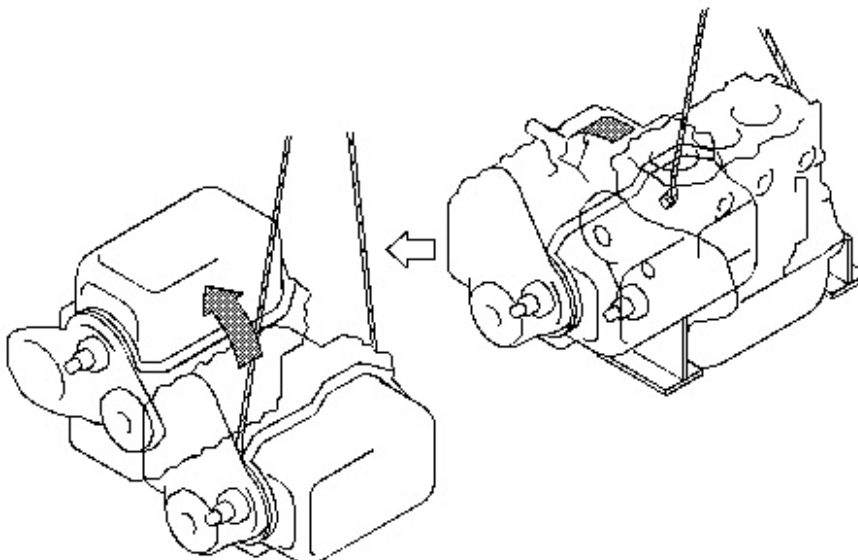

1. Attach the wire rope to the crankcase. Using a crane to hoist the crankcase and lay the crankcase with the side of the crankcase facing downwards.
2. After that, hoist the crankcase again and invert the crankcase.

Removing oil pan and oil pan gasket

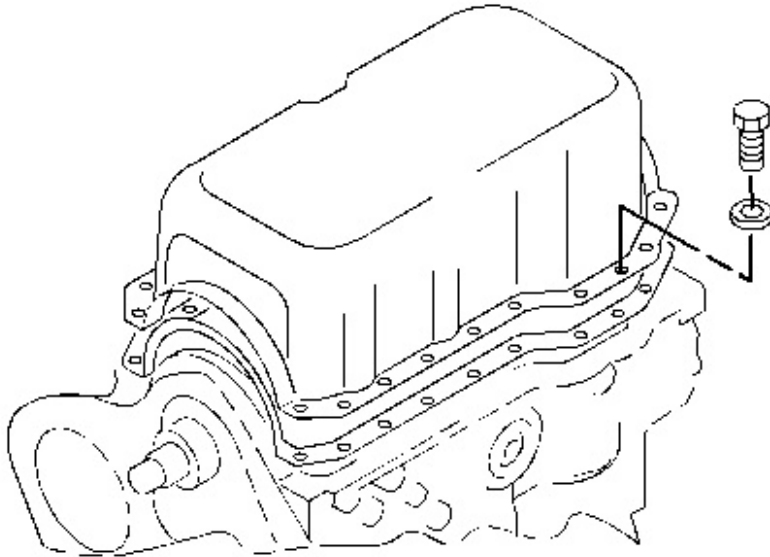

1. Remove the bolts from the oil pan, and remove the oil pan from crankcase.
2. Remove the oil pan gasket from crankcase.

Removing oil pump

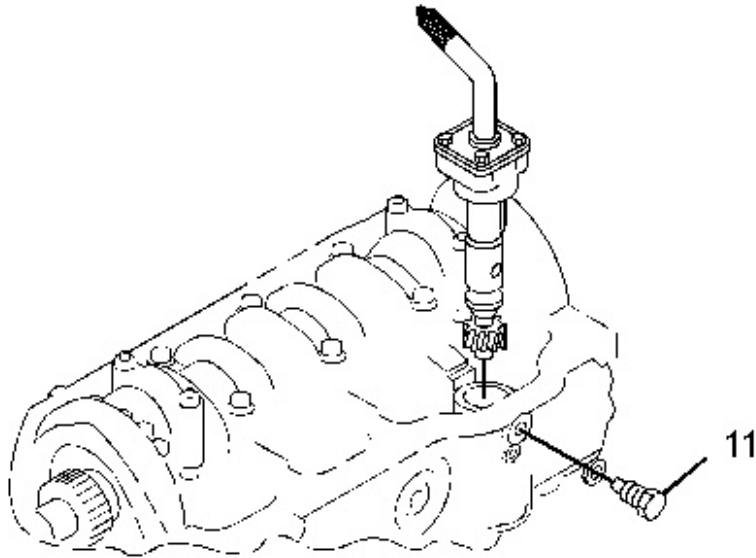

Illustration 10

g02210578

Remove the oil pump set bolts (11), and pull out the oil pump from crankcase.

Removing camshaft

Note: Be careful not to damage the cams of camshaft and the bushings.

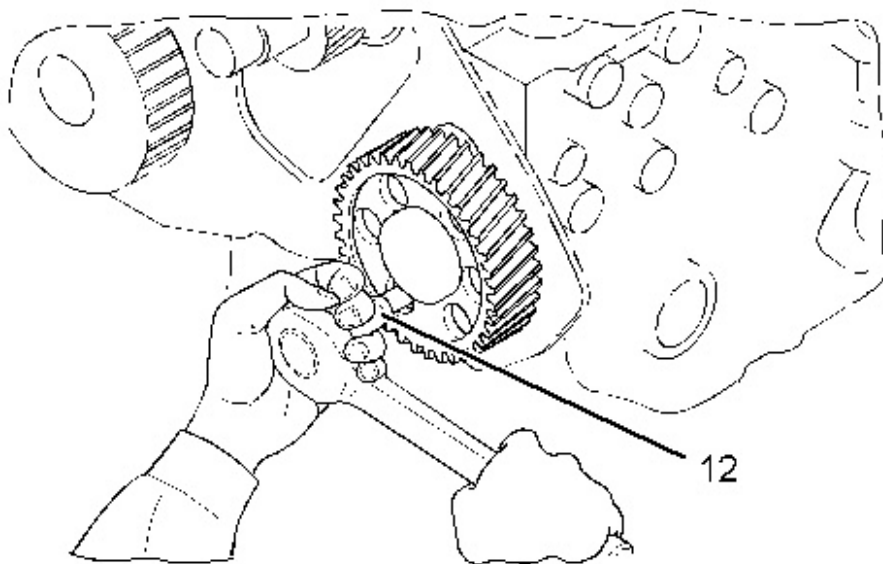

Illustration 11

g02210579

1. Rotate the camshaft to see the thrust plate bolt through the camshaft gear hole.
2. By using the socket P/N:34491-00300 (12), remove the thrust plate bolt.
3. Remove the camshaft from the crankcase.

4. Remove the tappet.

Inspect the thrust plate and camshaft (8) for damage and wear. Replace all the gaskets, seals, and O-rings during installation.

Removing front plate

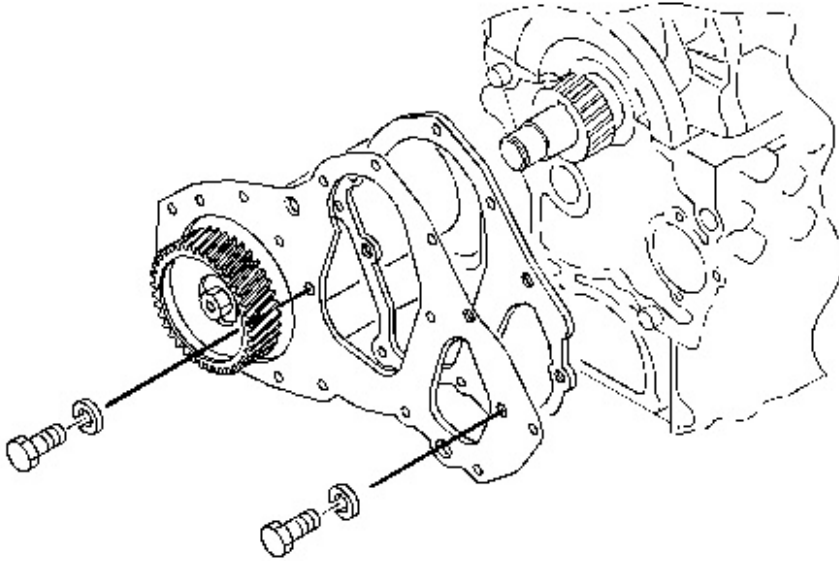

Illustration 12

g02210580

1. Remove the front plate bolts.
2. Remove the front plate from the crankcase.

Note: If difficult to remove the front plate, lightly tap the front plate with a plastic hammer.

[Previous Screen](#)

Product: MINI HYD EXCAVATOR

Model: 304D CR MINI HYD EXCAVATOR TYK

Configuration: 304D CR Mini Excavator TYK00001-UP (MACHINE) POWERED BY S3Q2 Engine

Disassembly and Assembly S3Q2 and S3Q2-T Engines

Media Number -KENR6786-03

Publication Date -01/08/2015

Date Updated -18/08/2015

i04111950

Piston, Connecting Rod, Crankshaft, and Cylinder Block - Disassemble and Inspect

SMCS - 1201-015; 1201-040; 1202-015; 1202-040; 1214-015; 1214-040; 1218-015; 1218-040

Disassembling and inspecting piston, connecting rod, crankshaft, and crankcase

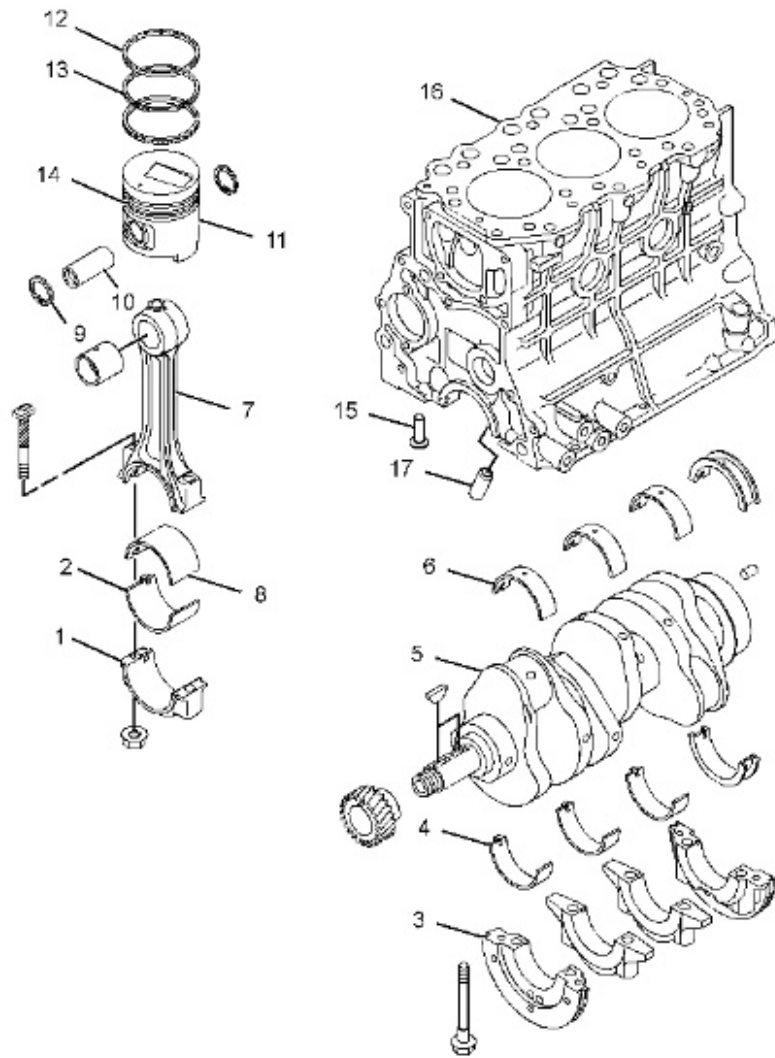

Illustration 1

g02315374

Disassembling sequence

- (1) Connecting rod cap
- (2) Connecting rod bearing (lower)
- (3) Main bearing cap
- (4) Main bearing cap (lower)
- (5) Crankshaft
- (6) Main bearing (upper)
- (7) Connecting rod
- (8) Connecting rod bearing (upper)
- (9) Snap ring
- (10) Piston pin
- (11) Piston
- (12) No.1 compression ring

(13) No.2 compression ring

(14) Oil ring

(15) Tappet

(16) Crankcase

(17) Check valve

Note: When replacing the crankcase, carefully remove parts (relief valve) mounted on the non-reusable crankcase so that can be reused.

Laying crankcase on its side

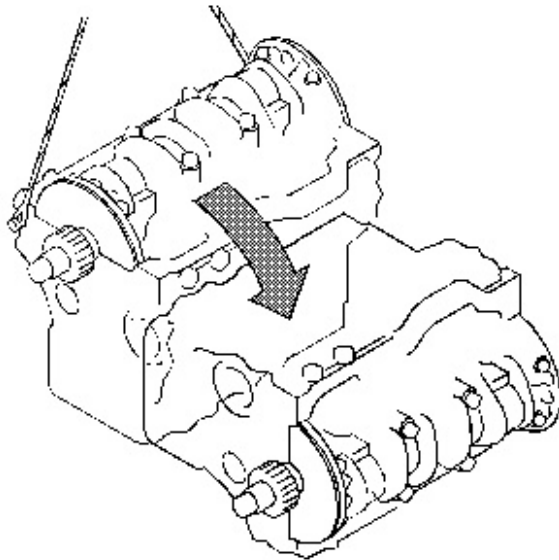

Illustration 2

g02315375

Attach the wire rope to the crankcase. By using a crane, hoist the crankcase and lay it with its side faced downwards.

Measuring connecting rod end play

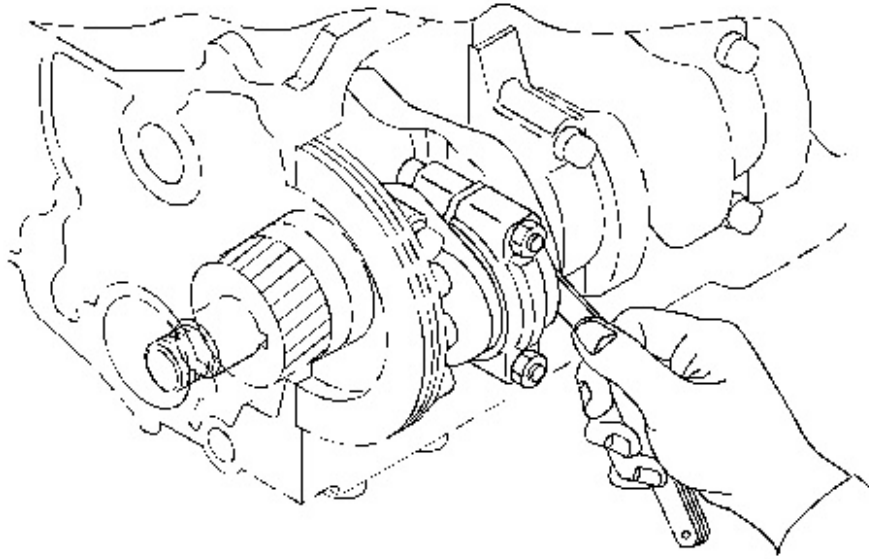

Illustration 3

g02210895

1. Measure the clearance (end play) between the connecting rod big-end and crankshaft by using the thickness gauge.
2. If the clearance beyond the limit, replace the connecting rod with new one.

Table 1

Item	Standard	Limit
Connecting rod end play	0.150 to 0.350 mm (0.0059 to 0.0138 inch)	0.500 mm (0.0197 inch)

Removing connecting rod cap

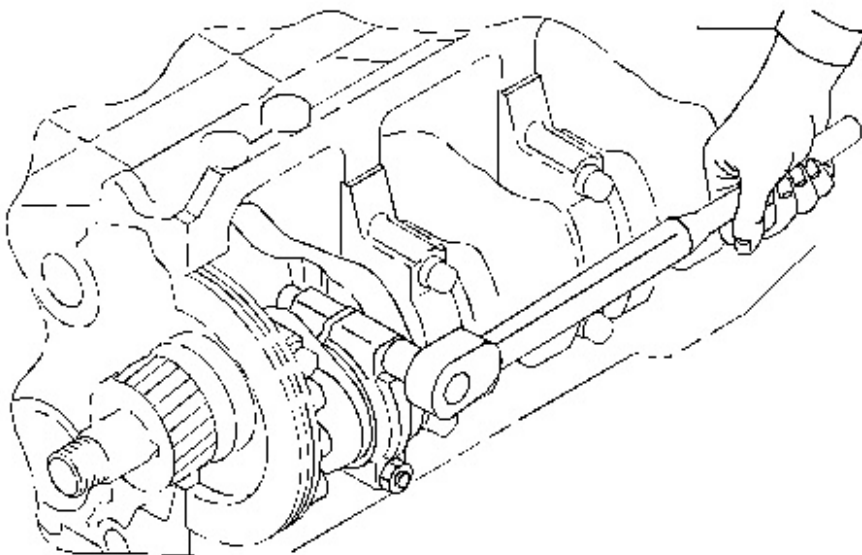

1. Mark the cylinder number on the connecting rod and connecting rod cap.
2. Remove the connecting rod cap.
3. Be sure to make the disassembled lower connecting rod bearing easy to recognize the cylinder number, and upper or lower.

Inspect the connecting rod cap (1) for scratches, cracks, dirt, clogged oil holes, and wear.

Note: Be careful not to damage the bearings. Be sure to arrange the disassembled bearings in the order for correct assembly.

Removing carbon deposits from the upper part of cylinder

Note: Be sure to remove carbon deposits from the upper part of the cylinder before removing the piston. Damage the piston and piston ring.

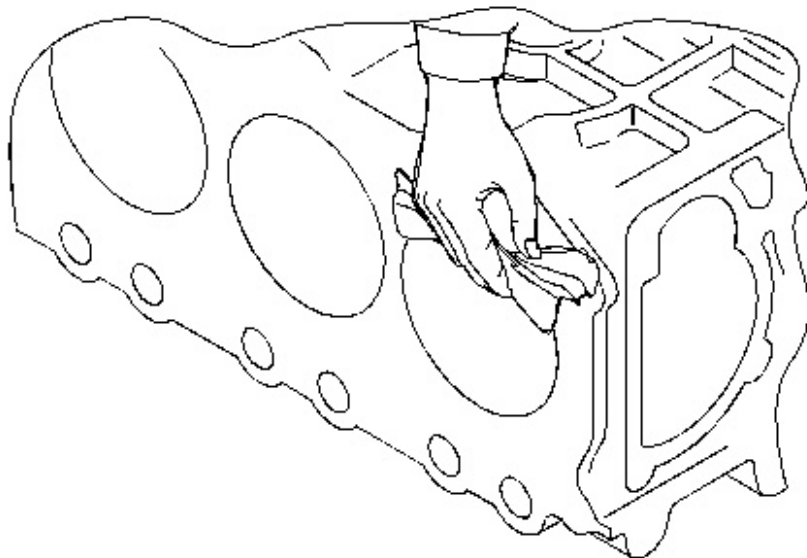

Remove carbon deposits from the upper part of cylinder using a cloth or oil paper. Be careful not to damage the inner surface of the cylinder.

Pulling out piston

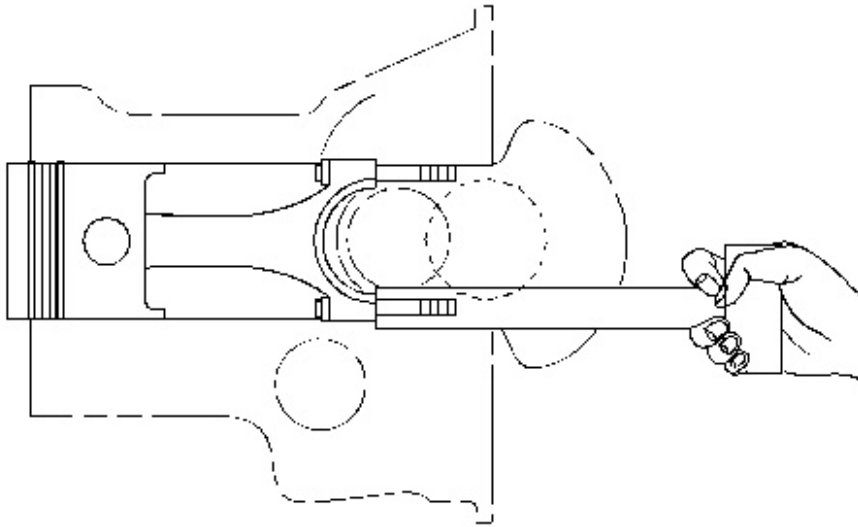

Illustration 6

g02210937

1. Turn the crankshaft to bring the piston to the top dead center.
2. Using a piece of wood such a hammer handle, push the mating surface of the connecting rod cap. Pull the piston and connecting rod upward from the cylinder.
 - Inspect the connecting rod (7) for serration for cracks, clogged oil holes, and wear.
 - Inspect the connecting rod cap bolts for damaged threads.
 - Inspect the piston (11) for surface scratches, cracks, damage, wear, and carbon deposits.

Removing piston ring

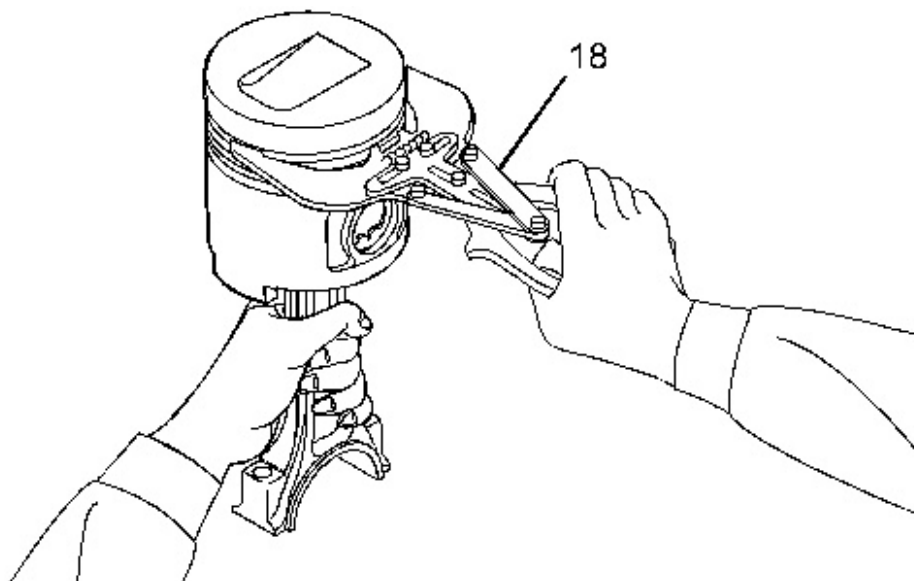

Illustration 7

g02210938

Remove the piston rings using piston ring pliers (18). Inspect both the compression rings and oil ring for wear, and damage.

Removing piston pin

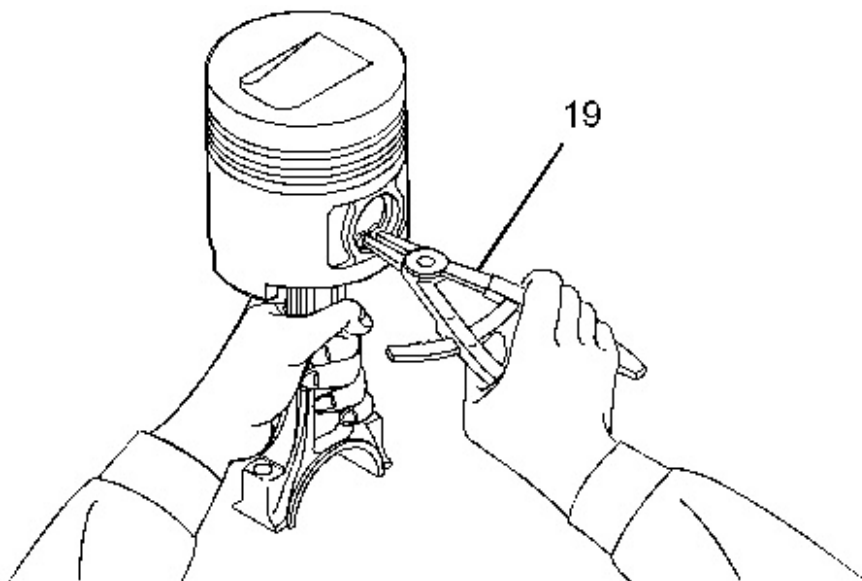

Illustration 8

g02210939

1. Using snap ring pliers (19), remove the snap ring. Inspect the snap ring (9) for fatigue.
2. Remove the piston pin, and separate the piston from the connecting rod.

Inspect the connecting rod small end bushing for wear and clogged oil holes. Inspect the piston pin (10) for wear.

Note: Heat the piston with a piston heater or in hot water if the piston pin is stubborn.

Upreaming crankcase

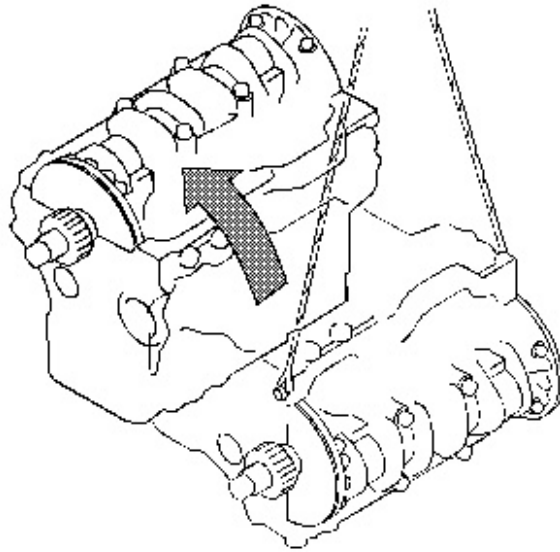

Illustration 9

g02315393

Uprear the crankcase softly with upper faced downward.

Measuring crankshaft end play

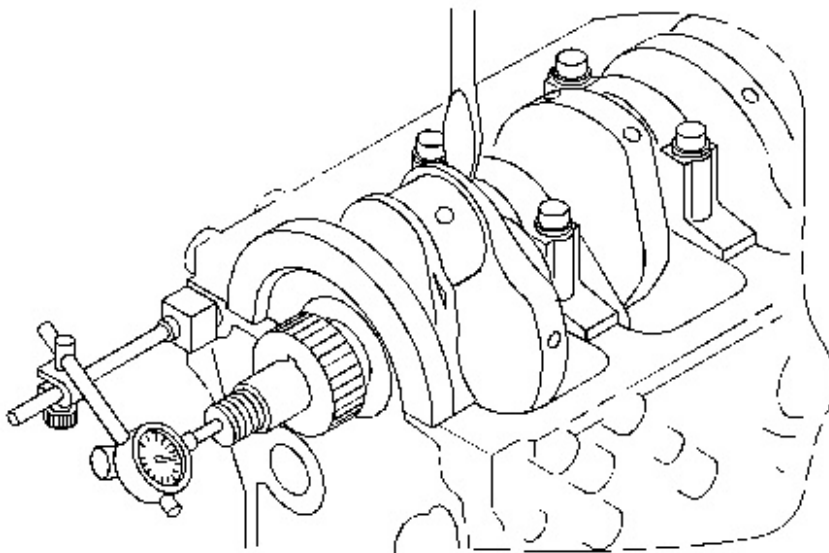

Illustration 10

g02210954

1. With attach the dial gauge to top of the crankshaft, measure the end play.
2. If measured value exceeds the limit, replace the flange bearing with new one.

Table 2

Item	Standard	Limit

Removing main bearing cap

Note: When removing the main bearing cap, be careful do not damage the lower main bearing lower that are attached to the cap. Also be careful not to drop those parts, which may damage the crankshaft.

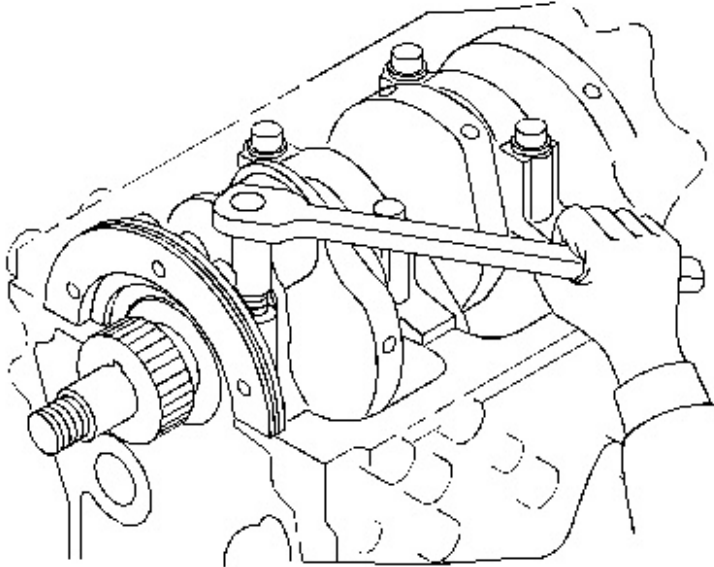

Illustration 11

g02210955

1. Unscrew the main bearing cap bolts. Inspect the main bearing cap bolts for damaged threads.
2. Unscrew the main bearing cap. Inspect the main bearing cap for cracks.

Inspect the main bearing cap (lower) (4) for scratches on inside and outside surfaces, corrosion, flaking, and seizing.

Note: Mark the bearings for the correct cylinder numbers.

Removing crankshaft

Note: Be careful not to damage bearings when removing the crankshaft.

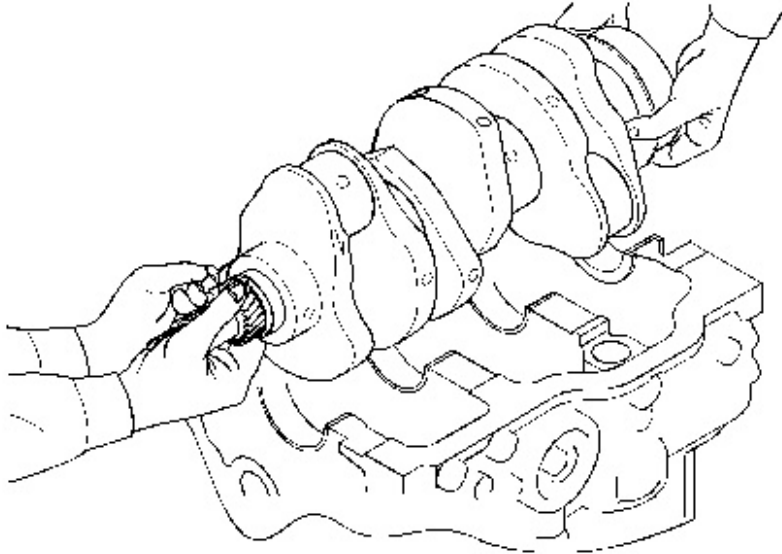

Illustration 12

g02315395

1. Slowly lift the crankshaft straight up.
2. Arrange the bearings in the order of disassembly so that the original positions are restored when reassembling.

Inspect the crankcase (16) for adhesion of water scale, corrosion, and flaking. Inspect the tappet (15) for wear.

Note: When raising the crankshaft, do not allow wire chain to come into contact with the crankshaft. To avoid damage to the crankshaft when raising, use a cloth belt or pad. Mark the bearings for the correct cylinder numbers.

Previous Screen

Product: MINI HYD EXCAVATOR

Model: 304D CR MINI HYD EXCAVATOR TYK

Configuration: 304D CR Mini Excavator TYK00001-UP (MACHINE) POWERED BY S3Q2 Engine

**Disassembly and Assembly
S3Q2 and S3Q2-T Engines**

Media Number -KENR6786-03

Publication Date -01/08/2015

Date Updated -18/08/2015

i04112012

Cylinder Head and Valve Mechanism - Inspect and Repair

SMCS - 1100-023; 1100-040; 1102-023; 1102-040

Measuring distortion of the bottom surface of the cylinder head

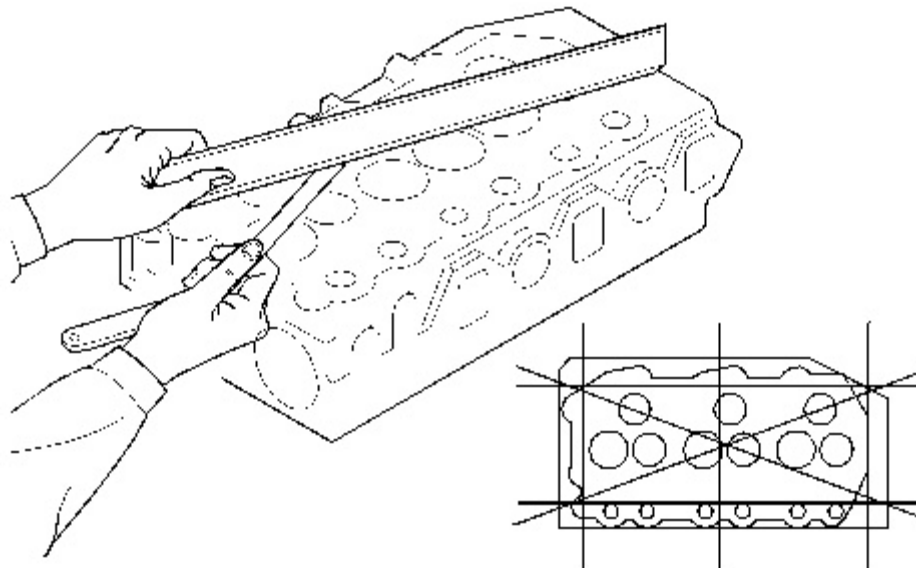

Illustration 1

g02315433

With a straight edge placed on the bottom face of the cylinder head, measure the bottom face distortion using a feeler gauge. If the measurement exceeds the limit, grind the bottom face using a surface grinder.

Table 1

Item	Standard	Limit
------	----------	-------



Suggest:

If the above button click is invalid.

Please download this document

first, and then click the above link

to download the complete manual.

Thank you so much for reading

Bottom surface distortion	0.050 mm (0.0020 inch) or less	0.200 mm (0.0079 inch)
---------------------------	--------------------------------	------------------------

Note: Do not grind the surfaces more than 0.20 mm (0.008 inch) in total (cylinder head bottom surface plus crankcase top surface).

Measuring clearance between rocker arm and rocker shaft

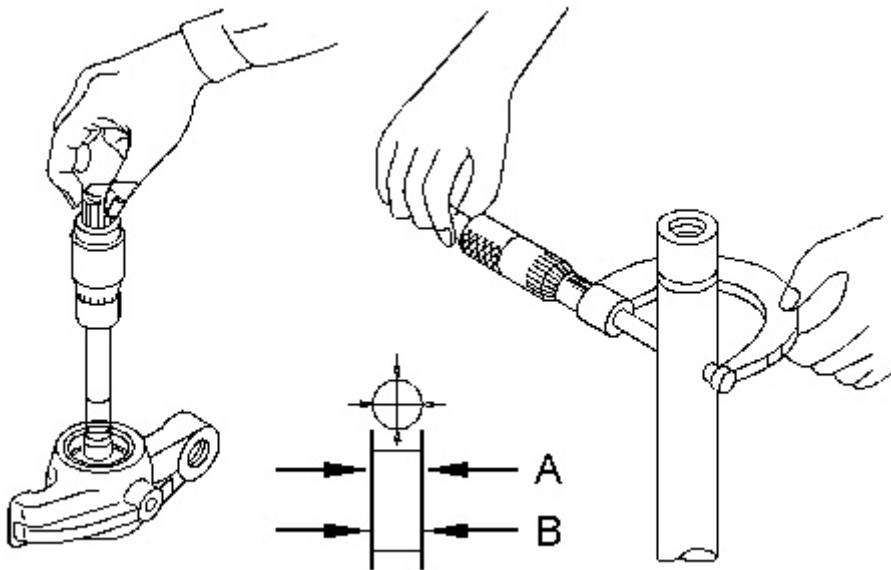

Illustration 2

g02212574

(A and B) Measuring points

Measure the inside diameter of the rocker arm and outside diameter of the rocker shaft. Replace the rocker arm or rocker shaft if the clearance exceeds the limit.

Table 2

Item	Nominal	Standard	Limit
Rocker arm inside diameter	19.0 mm (0.75 inch)	19.010 to 19.030 mm (0.7484 to 0.7492 inch)	-
Rocker shaft diameter	19.0 mm (0.75 inch)	18.980 to 19.000 mm (0.7472 to 0.7480 inch)	-
Clearance between rocker arm and shaft	-	0.010 to 0.050 mm (0.0004 to 0.0020 inch)	0.070 mm (0.0028 inch)

<https://www.ebooklibonline.com>

Hello dear friend!

Thank you very much for reading.

Enter the link into your browser.

The full manual is available for immediate download.

<https://www.ebooklibonline.com>